

Manual

coM.sat ISDN Basic

Contents

Contents	2
List of figures	4
Versions	5
Abbreviations	6
Literature references	8
1 Introduction	9
2 User safety information	10
2.1 Electrical safety.....	10
2.1.1 Air traffic safety	10
2.2 Environment with explosive materials	10
2.3 Road traffic safety	10
2.4 Non-ionising radiation	10
2.5 Electronic medical equipment	10
2.6 Measures to be taken in case of loss/theft.....	11
2.7 Transport	11
2.8 Where to install the devices	11
2.9 Damage and repairs	11
3 Functional description	12
3.1 Starting up the device	16
3.2 Installation of the coMsat.exe application	17
3.3 Configuration of the coM.sat ISDN Basic	18
3.3.1 Interface	19
3.3.2 ISDN Configuration	22
3.3.3 GSM/UMTS Configuration	25
3.3.4 Routing	27
3.3.4.1 Routing according to dialled number	28
3.3.4.2 Selection of providers by time and number	29
3.3.4.3 Callback Table and special routing	30
3.3.4.4 Automatically inserted country and area codes.....	30
3.3.5 Incoming calls	31
3.3.6 Outgoing calls	34
3.3.7 Fax/Data	37
3.3.8 Statistics	39
3.3.9 Voice	41
3.3.10 Unconnected Calls	43
3.3.11 Diversion	46
3.3.12 Virtual PBX	48
3.3.12.1 General Information	48
3.3.12.2 Configuration	49
3.3.12.3 Call Hold	50
3.3.12.4 Call Retrieve	51
3.3.12.5 Call Transfer	51
3.3.12.6 Licensing.....	51
3.3.13 Clock	53
3.3.14 Channel 1/2	55
3.3.15 Info	59
3.3.16 SMS	63
3.3.16.1 Receive SMS.....	64
3.3.16.2 Send SMS.....	64
3.3.17 Firmware	65

3.3.18	Terminal.....	67
3.3.19	Monitor.....	69
3.3.20	Additional information	71
3.3.21	Vendor functions	72
4	Installation and operating information	74
4.1	coM.sat ISDN Basic replaces network termination	74
4.2	coM.sat ISDN Basic in TE mode	76
4.3	coM.sat ISDN Basic in router mode	79
4.4	Transmit SMS	81
4.5	Fax transmission via PC	81
4.5.1	<i>Preparation of the PC for fax transmissions</i>	<i>81</i>
4.5.2	<i>Send fax messages</i>	<i>82</i>
4.5.3	<i>Receive fax message</i>	<i>84</i>
4.6	Data transmission via PC	84
4.6.1	<i>Preparing the PC for the transfer of data.....</i>	<i>84</i>
4.6.2	<i>Sending and receiving data.....</i>	<i>84</i>
4.7	Servicing / Remote servicing	84
4.7.1	<i>Servicing.....</i>	<i>85</i>
4.7.2	<i>Remote servicing.....</i>	<i>85</i>
4.7.3	<i>Read out/Transmit configuration.....</i>	<i>88</i>
4.7.4	<i>Software update.....</i>	<i>88</i>
5	Questions and answers	89
6	Technical data.....	90
6.1	Connector assignments	91
Appendix 1: LED Function		92
Appendix 2: Terminal commands.....		93

List of figures

Figure 1: Functional Groups	13
Figure 2: Front side of the coM.sat ISDN Basic	14
Figure 3: Top side of the coM.sat ISDN Basic	15
Figure 4: Rear side of the coM.sat ISDN Basic.....	15
Figure 5: coMsat.exe Installation	17
Figure 6: Interface	19
Figure 7: Automatic Load	21
Figure 8: ISDN Configuration.....	22
Figure 9: GSM/UMTS Configuration.....	25
Figure 10: Routing	27
Figure 11: Incoming calls.....	31
Figure 12: Outgoing calls.....	34
Figure 13: Fax/Data.....	37
Figure 14: Statistics	39
Figure 15: Voice	41
Figure 16: Unconnected calls	43
Figure 17: Diversion	46
Figure 18: Virtual PBX.....	48
Figure 19: License dialog	52
Figure 20: Clock	53
Figure 21: Channel 1/2	55
Figure 22: Module information	59
Figure 23: Module information in the terminal window.....	61
Figure 24: Unlock SIM card	62
Figure 25: Set prepaid credit	62
Figure 26: SMS.....	63
Figure 27: Firmware Update.....	65
Figure 28: Terminal	67
Figure 29: Trace recording	69
Figure 30: Monitor Configuration	70
Figure 31: Vendor Functions in channel 1/2	72
Figure 32: NT Installation.....	74
Figure 33: NT Configuration	75
Figure 34: TE Installation.....	77
Figure 35: TE Configuration.....	78
Figure 36: Router Installation.....	79
Figure 37: Router Configuration	80
Figure 38: Install modem	82
Figure 39: Send Fax Wizard	83
Figure 40: Remote Servicing	86

Versions

Vers. No.	Date	Description of the revision	Chapter	Amended by
1.0	15/03/05	First issue	All	SJ
1.1	11/04/05	Corrections	All	SJ
1.2	28/06/05	Power supply changed Progress indicator added Module information corrected Windows XP added Fixed network MODEM mentioned ISDN LED description improved	6 3.3.6 3.3.15 1 4.7.2 4.1	SJ
	19/07/05	TE and Router mode described		SJ
2.0	06/12/06	Complete review	All	SJ
2.2	11/04/07	Complete review; Fax/Data via PC	All 3.3.7, 4.5, 4,6	SJ
2.3	17/07/07	VPBX usage option	3.3.12	SJ
2.4	01/08/07	CLIP list	3.3.6	SJ
2.5	21/09/07	Return Call Announcement	3.3.10	SJ
2.6	28/05/08	Optional Sync/Relais board added	3.3.2,4.1, 4.3	SJ
2.7	15/01/09	Updated for many software changes	All	SJ

Abbreviations

EEPROM	E lectrical E rasable P rogrammable R ead o nly M emory: Memory circuit, which can be deleted by applying an electric voltage.
I ² C - Bus	I nter - IC B us
GSM	G lobal S ystem for M obile C ommunications
UMTS	U niversal M obile T elecommunications S ystem
SIM	S ubscriber I dentify M odule
SMS	S hort M essage S ervice
SMSC	S hort M essage S ervice C entre
ISDN	I ntegrated S ervices D igital N etwork
TC System	Private telecommunications switching system
NT - Mode	N etwork T ermination: in this case, the device is operated as a network terminal (NT), whereby both the electrical and physical parameters (Layer 1) are adapted as well as the accepting the data link service and addressing tasks for layers 2 and 3.
TE - Mode	T erminal E quipment: In this case the device is operated at the TC system like a TE2 device i.e. like an ISDN - compatible terminal.
P - P	P oint - to P oint: direct communication between two points in a network with each other. Communication is solely via this connection. The point-to-point connection is a variant of the wiring of the S ₀ interface, if only one terminal is available.
PMP	P oint-to- M ultipoint, the point to multipoint connection is the other variant of the configuration for the S ₀ bus. In this case several terminals (max 8) can be connected to the same connection. Of these 8 devices, 2 can establish a connection at any one time.
S ₀	The S ₀ interface is an internationally standardised interface for ISDN installations. This interface is made available by the NTBA on the line side. On the customer side, the interface is provided both for the connection of a telecommunications switching system (→ system connection) as well as for the connection of up to 6 ISDN devices (→ multiple device port).
EDSS1	Name of the Euro-ISDN protocol (European D-channel Signalling System No 1); was introduced with the transition of national ISDNs to the whole of Europe, whereby a data link protocol was introduced, which is supported by all the connected states. This protocol contains the mandatory performance characteristics, which control the establishment and clearance of a link, as well as providing several supplements. National network providers can extend these performance characteristics.

AOC	Advice of Charge: Performance characteristic of the EDSS1. Display of the connection charges incurred as tariff units according to the network provider's tariff during and at the end of a link that has been made.
RJ45	RJ45 is the name given to the eight-pole connector technique, which has a very simple but effectively working configuration. This connector technique is used in the ISDN wire range for the So connection. The connector is standardised in ISO 8877.
MSN	Multiple Subscriber Number → multiple subscriber number for a multiple device connection.
PBX	Private Branch Exchange

Literature references

Bergmann / Gerhardt	Taschenbuch der Telekommunikation Fachbuchverlag Leipzig
Kanbach / Körber	ISDN - Die Technik Hüthig Verlag
Siemens	TC35 - Documentation

1 Introduction

coM.sat ISDN Basic is a digital mobile phone adaptor (TA) which uses suitable GSM modules and SIM cards for voice communications and SMS transmissions. **coM.sat ISDN Basic** is connected to the external or internal ISDN (S₀) - port of an ISDN PABX. The **coM.sat ISDN Basic** mobile phone adaptor can then be accessed from each extension user. Conversely, each extension connected to the PABX can be reached from GSM mobile phones at the most favourable mobile phone tariff via the **coM.sat ISDN Basic** mobile phone adaptor.

The **coM.sat ISDN Basic** is assembled in a stable housing and is suitable for installation on horizontal or vertical surfaces.

coM.sat ISDN Basic is configured comfortably and user-friendly via the **coMsat.exe** Windows application. The devices can also be serviced remotely with the aid of this application. The application can run under Windows 98®, Windows 2000® and Windows XP® and should run on Windows ME® and Windows Vista® too.

The performance characteristics, functions and interfaces of **coM.sat ISDN Basic** are described in this document.

Furthermore, this manual also includes information on installation, use and diagnostics.

Users are explicitly requested to read the user safety information first.

The manufacturer reserves the right to make technical changes that serve the safety of the device and improve its operation.

Should you have any further technical questions, our hotline is available at +61 (0) 3 9016 3480¹.

Additional information is available from **rossking's** internet site:

www.rossking.com.au

Please note: This description applies to the **coMsat.exe** - Windows Application 3.1.0 (and newer versions) as well as the associated firmware for the **coM.sat ISDN Basic** (V1.3.1 and newer).

¹ DTMS - only 14 cent per minute from the german fixed telephone network

2 User safety information

The following information applies to the **coM.sat ISDN Basic**. As the cellular engines used in this device are manufactured by Siemens (TC35i), we explicitly refer to this company's respective safety regulations and operating manuals.

2.1 Electrical safety

The **coM.sat ISDN Basic** works with a nominal supply voltage of about 10 V. Furthermore, the device is connected to the S₀ local port of TAs. Therefore no further precautions are required to protect the user against high voltages from this device. However, it should be noted that the user must ensure that they discharge any static charge they may have before working on the device.

2.1.1 Air traffic safety

Use of cellular engines in aircraft can impair their navigation systems and interfere with the mobile radiophone network. Their use has therefore been forbidden by law. The **coM.sat ISDN Basic** must therefore not be used on board aircraft. Breach of requirement can cause temporary or complete suspension of the cellular engine services and / or legal steps to be taken against the offenders.

2.2 Environment with explosive materials

The **coM.sat ISDN Basic** is not approved for use in potentially hazardous atmospheres. The user is therefore advised not to use the TA close to such areas, which could be e.g. at petrol stations, in fuel depots, in chemical works or during blasting. Should this nevertheless be necessary, the user should take steps to ensure that no risk can occur.

2.3 Road traffic safety

If the devices are used in vehicles that are used in public road traffic, the national regulations for telephoning in vehicles applicable for the country in which the device is must be complied with.

2.4 Non-ionising radiation

As in all radio transmission devices, the user should note that it is advisable for satisfactory use of the devices and safety of the user that the device is only used in its normal operating position.

2.5 Electronic medical equipment

The operation of radio transmitters, which includes cellular engines, can impair the function of medical devices that have not been properly shielded. Please ask advice of your doctor or the manufacturer of the medical device.

2.6 Measures to be taken in case of loss/theft

If the **coM.sat ISDN Basic**, the cellular engines or the SIM cards used are lost, inform your network provider immediately to prevent any misuse.

2.7 Transport

The packaging ex works is designed to protect against mechanical damage and should be stored for any later transports. To avoid moisture condensation, time must be allowed for the devices to slowly adapt to the ambient temperature (if they have been stored in an environment with differing temperature) before starting them up.

2.8 Where to install the devices

The devices should be installed so that they are protected against direct sunlight and heat. This increases both the reliability of the operation of the devices as well as their service life, as the components used are less thermally stressed.

The devices should also only be used with the power supplies that they are supplied with or an original spare part.

The cables to the devices should be installed so that they do not cause any physical risk. Power cables should be installed separate from the signal cables.

The devices should only be installed by adequately trained personnel.

2.9 Damage and repairs

For safety reasons, the device should not be used in case of noticeable damage or if it has been exposed to moisture.

Repairs to the device should preferably only be carried out by the manufacturer or their authorised agents. Should this not be possible at any time, the repair must be carried out by an adequately qualified person, whereby only original parts should be used.

The device must be disconnected from the voltage supply before each repair.

3 Functional description

The **coM.sat ISDN Basic** connects the telephone system to the GSM network. The device can be operated both in NT mode as well as TE mode, namely either as a “point to point“ connection (P - P) or as a “point to multipoint“ (PMP) connection. It is connected to a local S₀ port of the telephone system.

coM.sat ISDN Basic is available as a two channel design. It is intended for use in the GSM 900 and GSM 1800 network, if suitable SIM cards are used.

The use of the Siemens TC35i cellular engines not only enables voice communications, but also the transmission (sending and receiving) of data, faxes and SMS using a PC and the USB interface for direct access to the cellular engines. The most important user facilities of the TA are:

GSM services:

TS11	Voice, full rate and enhanced full rate, DTMF
TS12	Emergency call function
TS21	SMS, text and PDU mode

Supporting services:

CLIP	Calling Line Identification Presentation
CLIR	Calling Line Identification Restriction
CFU	Call Forwarding Unconditional
AoC	Advice of Charge
BAOC	Block All Outgoing Calls
BOIC	Block Outgoing International Calls
BAIC	Block All Incoming Calls
COLP	Connected Line Identification Presentation

Hardware interfaces:

USB	For programming and SMS	
RJ45	for connection to the TC system	ISO 8877
RJ45	for the synchronisation port and ISDN network	ISO 8877
	Cardholder for small 3V SIM cards	
SMA	RF links for the GSM antennas	
	Power Supply Connector	
	LEDs for displaying the operating condition	

Programming:

Configuration of the device settings via the Windows application **coMsat.exe**
Remote servicing for changes to the programming, software updates, and traces
Setting NT/TE mode via the configuration
Call charge information can be set between 0 and 240 seconds
Comfort suffix dialling (post selection dialling; positive and negative list)
Channel analysis and output of the signal quality
Loudness adjustment

To realise the above features, a microprocessors switching has been developed which controls the interaction of the various functional groups of **coM.sat ISDN Basic**. These are illustrated in the following sketch.

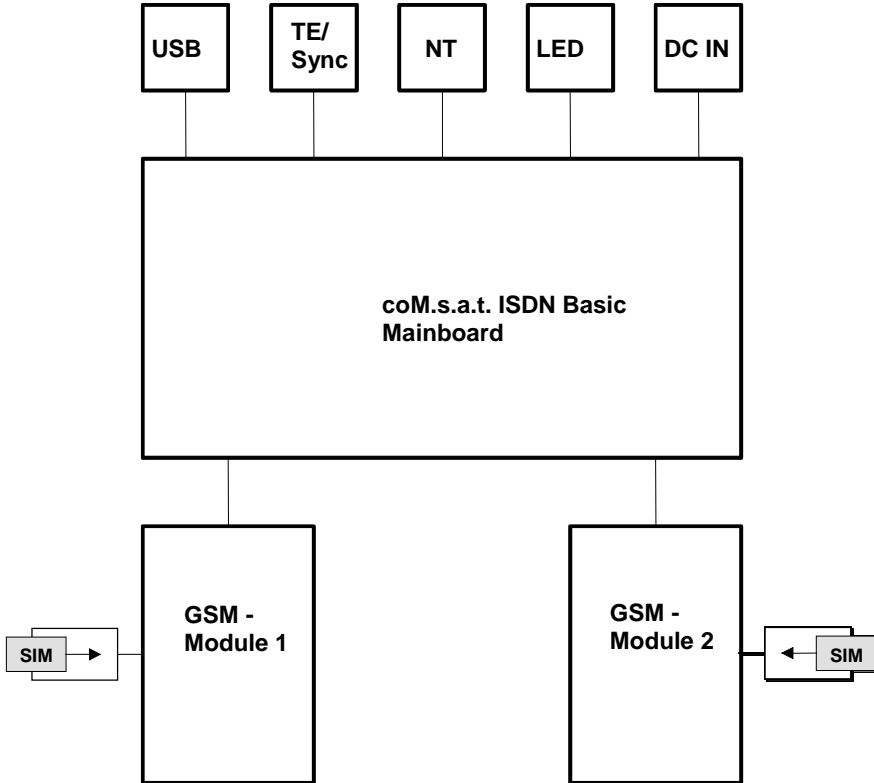

Figure 1: Functional Groups



Figure 2: Front side of the coM.sat ISDN Basic

On the front side are located:

- the connector for the power supply
- 2 SIM card readers
- the connector for the USB port (USB-B)
- the jack for the NT connection (RJ-45)
- the jack for the TE connection or the synchronisation (RJ45)



Figure 3: Top side of the coM.sat ISDN Basic

On the top side, there are the LED control indicators.

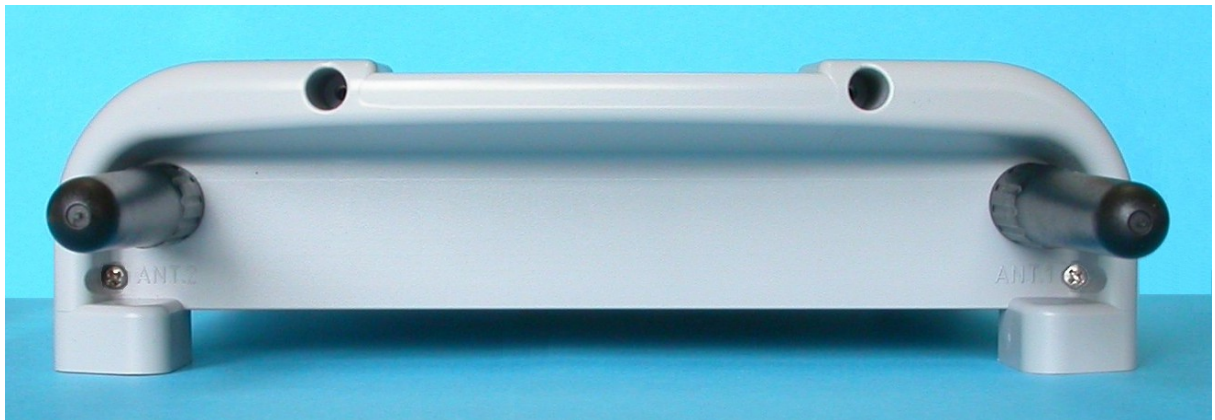

Figure 4: Rear side of the coM.sat ISDN Basic

On the rear side, there are the two RF- (SMA) connectors for the antennas, with antennas screwed in.

The connections and significance of the LED's are labelled to prevent errors. Before starting up the device, the SIM cards must be inserted into the provided holders. Two 3V SIM cards are required for full channel availability, but usage with one SIM card is possible.

To insert the SIM cards in the device, first push in the round yellow button next to the cardholder with a blunt, thin tool and then remove the cardholder. The SIM card is then placed in the cardholder and inserted into the card reader together with its holder. The contact area of the cardholder must be facing the rear of the device.

Attention: When pushing in the card, ensure that it does not fall out of the cardholder and that the card is correctly inserted in the cardholder guides. The device requires 3V SIM cards for operation!

3.1 Starting up the device

The SIM cards should be inserted into their reader slot first. Then the necessary cables are connected: Connection to the TC system as NT or TE, a connection to the PC's USB port on which the **coMsat.exe** application is installed, and finally the antenna cables.

Note 1: The GSM modules used in the **coM.sat ISDN Basic** for communication via the GSM network operate with an internal voltage of 3V. Therefore, for proper operation, SIM cards that can still operate with a working voltage of 3V must be used. All new SIM cards usually fulfil this requirement. If older cards (designed for a voltage of 5V) are used, the device possibly cannot log into the network - despite input of the correct PIN - because the SIMs cannot operate correctly at a voltage they weren't designed for.

Note 2: When looking at the front of the device, the left-hand SIM card is assigned to channel 1 and the right-hand card to channel 2.

Once it has been installed, the device can be switched on by inserting the power jack. This is indicated by the green LED which is labelled "Power".

All the relevant parameters in the device are deleted in the factory before delivering the **coM.sat ISDN Basic**, so that it must be set for the individual installation. Therefore, when installing the TA for the first time, it must be configured using the **coMsat.exe** application. To do this, a USB data link must be established between the **coM.sat ISDN Basic** and the PC on which the application is installed.

3.2 Installation of the coMsat.exe application

The coMsat.exe Windows® application is used to configure the **coM.sat ISDN Basic**. It is copied into a suitable directory on a PC together with two text files:

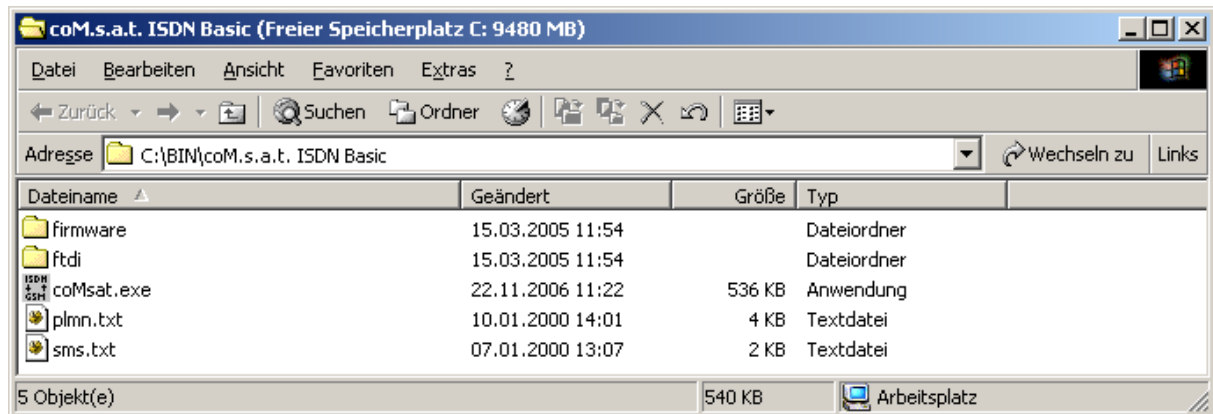

Figure 5: coMsat.exe Installation

The **coMsat.exe** application can now be executed from this directory or via a symbolic link that can be created manually e.g. on the desktop. A free USB port on the PC is required for operation with the **coM.sat ISDN Basic**.

coMsat.exe needs a virtual COM port to access the ISDN Basic. To install it, the current user must have administrator rights and the contents of the FTDI folder must be stored in a suitable directory. If the ISDN Basic is attached to the PC for the first time, the Windows® hardware assistant automatically reports a new device. It asks for the installation files contained in the FTDI folder. After installation is completed, a new virtual COM port has been added, e.g. COM3. This port must be used in **coMsat.exe**.

The virtual device driver is supplied by Future Technology Devices International Ltd., the manufacturer of the USB/RS 232 converter used in the ISDN Basic. If another driver is required, it can be obtained from www.ftdichip.com. The driver for FT232BM must be used. The following four files in the FDTI distribution must be replaced by those shipped with the ISDN Basic:

- FTDIBUS.INF
- FTDIPOINT.INF
- FTDIUN2K.INI
- FTDIUNIN.INI

3.3 Configuration of the coM.sat ISDN Basic

The **coM.sat ISDN Basic** is configured with the aid of the **coMsat.exe** Windows® application.

After starting the application by double-clicking the application's icon, the main application window is opened. Several file cards are displayed which control the various functions. These are supplemented by the typical Windows® application menus, such as **File**, **Connection**, **Configuration**, **Info**, **Firmware**, **Terminal**, **Monitor**, **View**, and **Help** and a symbol bar for quick access to the **New**, **Open**, **Save**, **Login**, **Logout**, **Load/Save Configuration**, **Load Monitor**, **Load Status** and **About** commands.

Various function groups are arranged on the file cards so that they form meaningful units. These are:

- Interface
- ISDN Cfg
- GSM Cfg
- Routing
- Incoming Calls
- Outgoing Calls
- Fax / Data
- Statistics
- Voice
- Unconnected Calls
- Diversion
- Virtual PBX
- Clock
- Channel 1
- Channel 2
- Info
- SMS
- Diversion
- Terminal
- Monitor

Note: The statistics, voice announcement, unconnected calls and diversion functions are only activated if there is a valid Basic Pro license (see 3.3.15). The virtual PBX functions are only activated if there is a valid virtual PBX license (see 3.3.12.6).

3.3.1 Interface

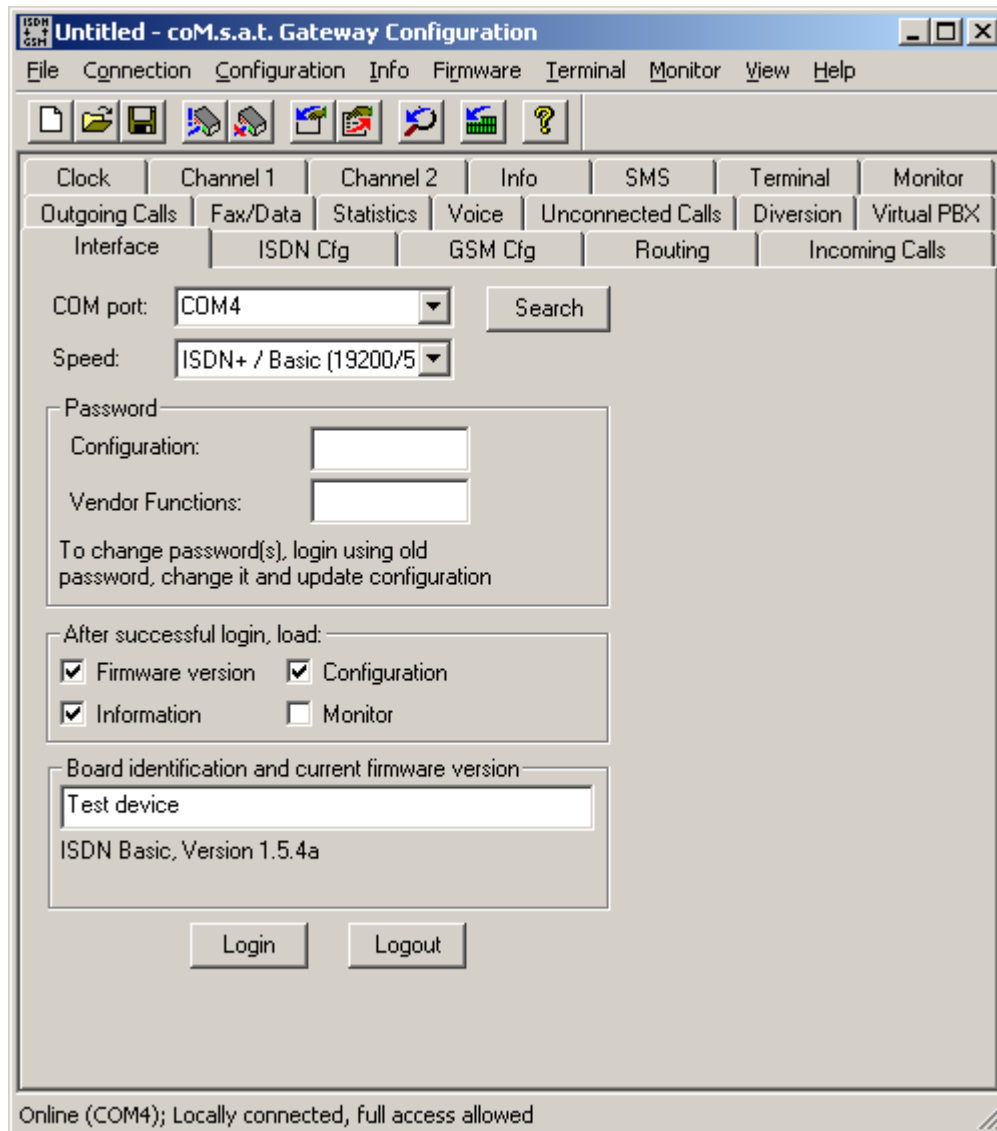

Figure 6: Interface

After starting the **coMsat.exe** application, the connection to the device is made via the "Interface" tab. Upon clicking the tab marked "Interface" it will come to the foreground and its contents will become visible.

The PC interface which shall be used for the data link to the **coM.sat ISDN Basic** is selected using the "COM port" drop down list box. It is also possible to let the application choose the port itself, using the "search" button. Should the application be unable to find a connected **coM.sat ISDN Basic**, it will issue the message "No device found!".

Many functions require an authentication of the user. This is done by clicking on the "Login" button also located on this tab. The authentication is removed by clicking the "Logout" button. The termination of **coMsat.exe** automatically removes authentication. Therefore explicit logout is only required if **coMsat.exe** remains connected to the ISDN Basic after the user leaves it.

To prevent unauthorised persons from logging into the TA and altering the configuration, at least the configuration password should be entered in the "**Password**" box. Each password consists of max. 19 alphanumeric characters. The various function groups within the **coM.sat ISDN Basic coMsat.exe** application are then accessible with differing protection.

Users who do not know either of these passwords can carry out all the unprotected functions on the device. They connect to the device by calling up "**Connection**" on the menu bar and calling up "**Go Online**" in the menu that opens, or simply use the desired function. The applications then connects to the **coM.sat ISDN Basic**. In this mode, the device configuration can be read, but not altered. SMS can be sent and received and any SMS received can also be read. The same procedure applies to remote access to the device.

However, the configuration settings can only be altered by logging in with a configuration password. Then all configuration data can be read out, amended and resaved. The "**Vendor Functions**" password makes further functional blocks accessible, via which the various network operators can be authorised or excluded.

If a password is entered, this password is transferred to the TA together with the configuration data. The next time the TA is logged into, the password must first be entered in the relevant box.

A password can be deleted or altered after logging in by deleting the relevant box for the password or entering another password. The new password is then valid after the next update of the configuration.

On the interface tab, the user can specify additional actions after successful login. The firmware version, the configuration of the device, the status information and the monitor can be loaded. The first three are activated by default on every execution of the software.

The firmware name and version (if loaded) and the user configurable device identification are also displayed on the interface tab. The device identification is stored in the device on updating its configuration and displayed on the interface tab after reading the configuration. Its purpose is to allow easy recognition of different devices in a multi-device installation.

The configuration data of one or several devices can be saved as usual in Windows®. The files contain the configuration, the firmware ID, the device information and the monitor contents, if these have been loaded before.

At the bottom of the **coMsat.exe** window there is a state bar which displays the

current actions. The state of the link (online/offline) and the port of the PC via which the data is transmitted when a link is made (e.g. "Online (COM 1)") is displayed on the left-hand side of the bar.

The "**Connection**" menu contains another command, i.e. "**Automatic Load**". This command opens the following dialog:

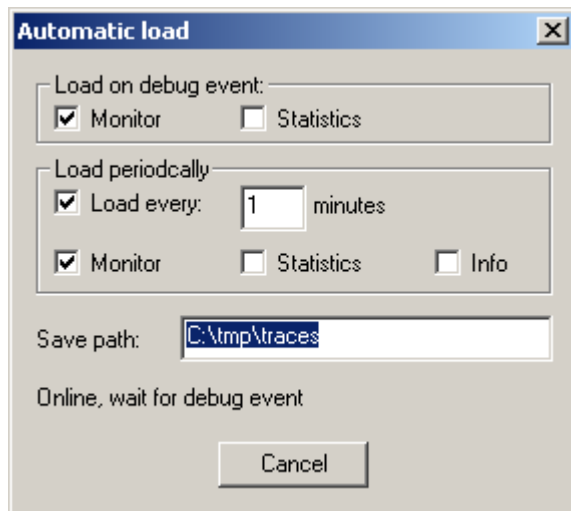

Figure 7: Automatic Load

As long as this dialog is open, **coMsat.exe** checks the messages from the device and starts an automatic load if it reports a restart. It can load the monitor and the statistics as selected by the first two options.

The load process can also be started periodically. To enable this, the option "**Load every ... minutes**" must be activated and the period set as desired. The automatic can load the monitor, the statistics and the status information as selected by the options. The statistics can only be loaded if the license for extended functions is available, otherwise the option is disabled.

If the automatic load is done for monitoring a long period, the load timeout should last 3 – 5 minutes in order not to lose information. If only statistics is loaded, 1 hour is sufficient. To load the statistics, a login must be possible so the passwords must be entered correctly. The automatic load function logs in before loading the statistics, even if already logged in. This is done because a restart might have caused a logout and then the statistics could not be loaded anymore.

3.3.2 ISDN Configuration

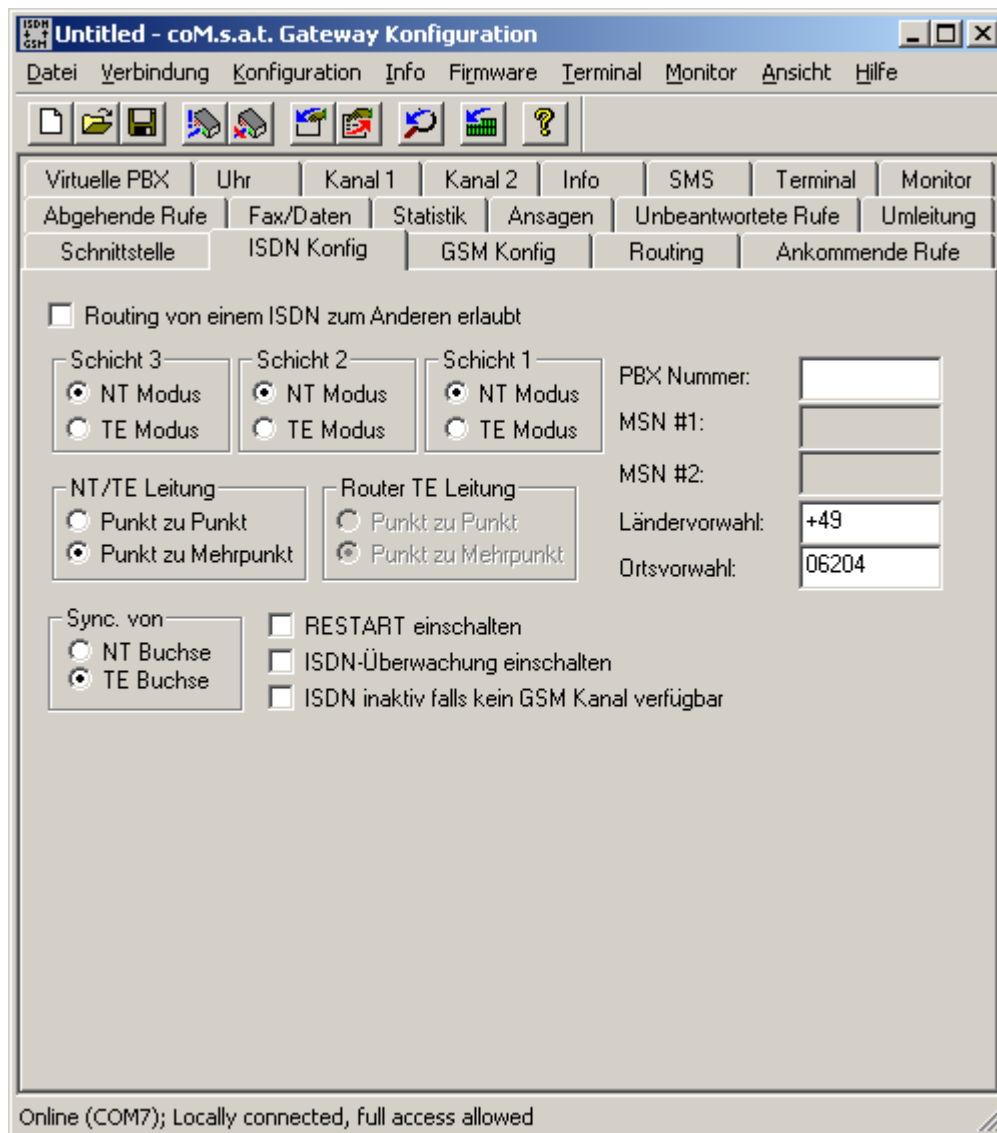

Figure 8: ISDN Configuration

The settings required for operation with the telephone system are made in the "ISDN Cfg" tab. When configuring the ISDN link, layers 1 to 3 are independently set for operation of the **coM.sat** ISDN Basic in NT or TE mode.

NT-Mode operation

In this mode the device presents itself to the telephone system as the ISDN network operator's network terminator. The connection to the **coM.sat ISDN Basic** is set up as a point-to-point or point-to-multipoint connection.

If the telephone system additionally has a fixed network connection and it reports too many errors (frame slips, bit slips), a synchronisation may be necessary. These types of errors are unimportant for voice communications. However, in mostly larger TC systems with more elaborate trouble shooting procedures, problems can occur during operation that can cause this “faulty” port being switched off. This can be avoided by synchronisation. In this case, the synchronisation input of the **coM.sat ISDN Basic** is connected directly with the system port (fixed network). The synchronisation clock is then derived from this signal.

If an optional add-on board is employed, it is possible to derive the synchronization clock from the NT port rather than the synchronization port. The parameter field labelled “**Sync from**” defines which port is used for synchronization. If the synchronization on the NT port is selected, the connected TE device must use a clock on that port synchronized to another source. Note: Since the presence of the add-on board is not detected, the parameter field is always enabled in NT mode even if the add-on board is not employed. See also chapters 4.1 and 4.3.

The PBX number entry also depends on the telephone system. Some systems do not require an entry here. As the entry of Multiple Subscriber Numbers isn't necessary in NT-mode, their respective boxes are inactive.

TE-Mode operation

If the **coM.sat ISDN Basic** is to be used in TE-mode, that is like a simple extension, then click the corresponding radio button for layer 3. Layers 2 and 1 will automatically be set to TE-mode. In this mode (operating on the telephone system's internal S0 bus) there is usually a point-to-multipoint connection. Therefore the line type is automatically set to this type of connection.

It is also often necessary to identify those extensions (Multiple Subscriber Numbers 1 and 2) via which the device is identified by the telephone system. Both GSM channels may be addressable by the same MSN if supported by the telephone system. If at least one MSN is empty, the device accepts any called party number and uses that number for the outgoing call. This means that the MSN is dialled via GSM, which is usually not desired. This function is useful if there is a diversion or VIP number programmed for each possible MSN, so that the MSN is converted into a valid GSM number.

If used in TE-mode, as terminal equipment, no synchronisation is necessary.

Router operation

If the **coM.sat ISDN Basic** shall be able to route calls from one ISDN port to the other, then activate the box labelled “**Allow routing from one ISDN port to the other**”. Layers 3, 2 and 1 will automatically be set to NT-mode because this reflects the setting of the ISDN port labelled “NT”. The line type automatically changes to point-to-point connection. The mode of layers 2 and 1 and the line type may be changed subsequently, but layer 3 of the NT port remains in NT mode, layers 3 to 1 of the TE port always operate in TE mode, and the line type setting applies to both ports.

The PBX number entry also depends on the telephone system. Some systems do not require an entry here. As the entry of Multiple Subscriber Numbers isn't necessary in router mode, their respective boxes are inactive.

The ISDN line monitoring is activated via the “**Enable ISDN Watchdog**” option box. In this case, if faults are registered in the ISDN layers 1 or 2, a warm restart is carried out approx. every 100 seconds.

The “**Enable Restart**” checkbox defines whether or not the **coM.sat ISDN Basic** sends the telephone system a restart command after a cold start or reset. Usually this option need not be set. It can be set to terminate any active calls after a restart of the device, but there are also TC systems that do not react on restart messages and thus make the **coM.sat ISDN Basic** inaccessible until a timeout terminates the restart procedure.

The option “**ISDN inactive if no GSM channel available**” can be enabled to activate the ISDN port (either NT or TE depending on the mode) only if at least one GSM channel is ready for calls. Otherwise the ISDN is deactivated and a PBX can use this information to route calls to other ports. This option is deactivated in router mode, because otherwise it would not be possible to make calls to PSTN if no GSM channel is available.

The country and area code are set in separate input boxes. The country code is the international dialling prefix (e.g. “+49”). The area code is usually the prefix for phone numbers in the same town that the TA is located and is therefore omitted when calling a number in the same area (e.g. “06204”). Entering these numbers at this point saves you the effort of entering them during later definitions of number lists (e.g. Net Access Numbers).

If not otherwise specified, the **ISDN Basic** assumes that international calls start with “00” (or “+”) and national calls start with “0”. These settings can be modified by appending the correct setting to the country and area code separated with a slash (e.g. “+1/011” as country code and “.../1” as area code for USA and Canada).

The current configuration of the **coM.sat ISDN Basic** can be enquired by clicking on “**Configuration**” in the menu bar and then selecting “**Query**” from the menu. Alternatively, the short cut keys

<Alt> <C>

and

<Q>

can be used or the button “Query Configuration” in the toolbar can be pushed.

After entering a new configuration or altering the current configuration, this can be saved via the “**File**” menu or can be transferred to the **coM.sat ISDN Basic** via the USB data link. This is done either via “**Update**” in the “**Configuration**” menu or by pushing the toolbar button “Update Configuration” or by entering the relevant keys on the keyboard.

A configuration file that has already been stored can be loaded again using the file menu and transferred to the device as described.

3.3.3 GSM/UMTS Configuration

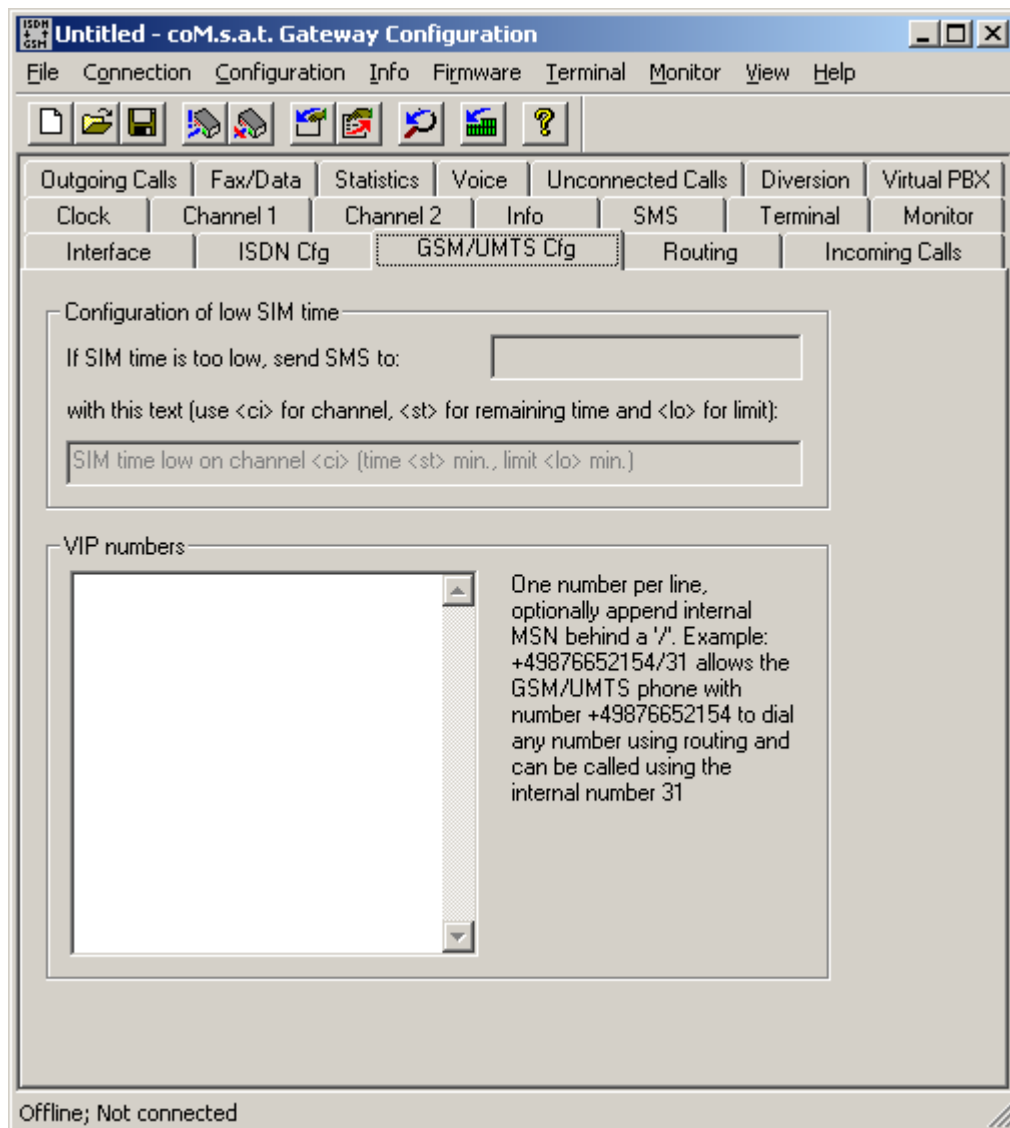

Figure 9: GSM/UMTS Configuration

This page is used to configure GSM/UMTS specific options.

The **coM.sat ISDN Basic** implements a time based supervision of prepaid credits. The credits themselves are dynamically programmed using the command “Set Prepaid Time“ in menu “Info“, which is described in chapter 3.3.15. Each channel is programmed a separate threshold, see chapter 3.3.14. If the credit falls below that threshold, the channel is not used anymore. The GSM configuration on this page configures additional behaviour in this case.

A GSM phone number can be programmed which shall receive an SMS if the credit becomes low. If no number is programmed, no SMS is sent. If a number is

programmed, the second input field determines which text is sent with the SMS. This text allows three place holders:

- <ci>: Is replaced by the number of the channel with low credit
- <st>: Is replaced by the remaining time credit
- <lo>: Is replaced with the programmed threshold

The VIP number list “**VIP numbers**” contains GSM phone numbers that get a special treatment. Each line contains a phone number and may also contain an MSN in the format <GSM number>/<MSN>. The MSN may be used to define short numbers for the members of the VIP list. If this MSN is called from any source (i.e. NT, TE or GSM), the call is connected to the associated GSM phone number. If a call comes in from a VIP number, the associated MSN is transmitted as calling party number in the ISDN messages.

VIP users always have the right to dial in even if the channel’s dial in option is switched off (“Call Default”, see 3.3.14). This allows to define a specific user group that may dial any number while normal users only call the default extension.

VIP users also use the routing function (see 3.3.4). While normal users calling from GSM are always connected to the PBX, VIP users may also call to PSTN or GSM depending on the called number and the programmed routing.

If a VIP number is called, the calling party number (the number belonging to the SIM card) is always shown to the VIP user, even if the channel in use has the option CLIR enabled, thus suppressing the number presentation. This does not enable the use of the return call handling in this case, because then a VIP won’t be able to use the VPBX anymore if a return call is stored for him.

The functions of the virtual PBX are also accessible to VIP users (see 3.3.12). Thus all GSM users contained in this list can use all functions normally available only to PBX extensions. Therefore these phone numbers are also called virtual extensions.

Note: The device uses the country and area code settings for the GSM number so that only one notation of a number need to be entered in the list.

3.3.4 Routing

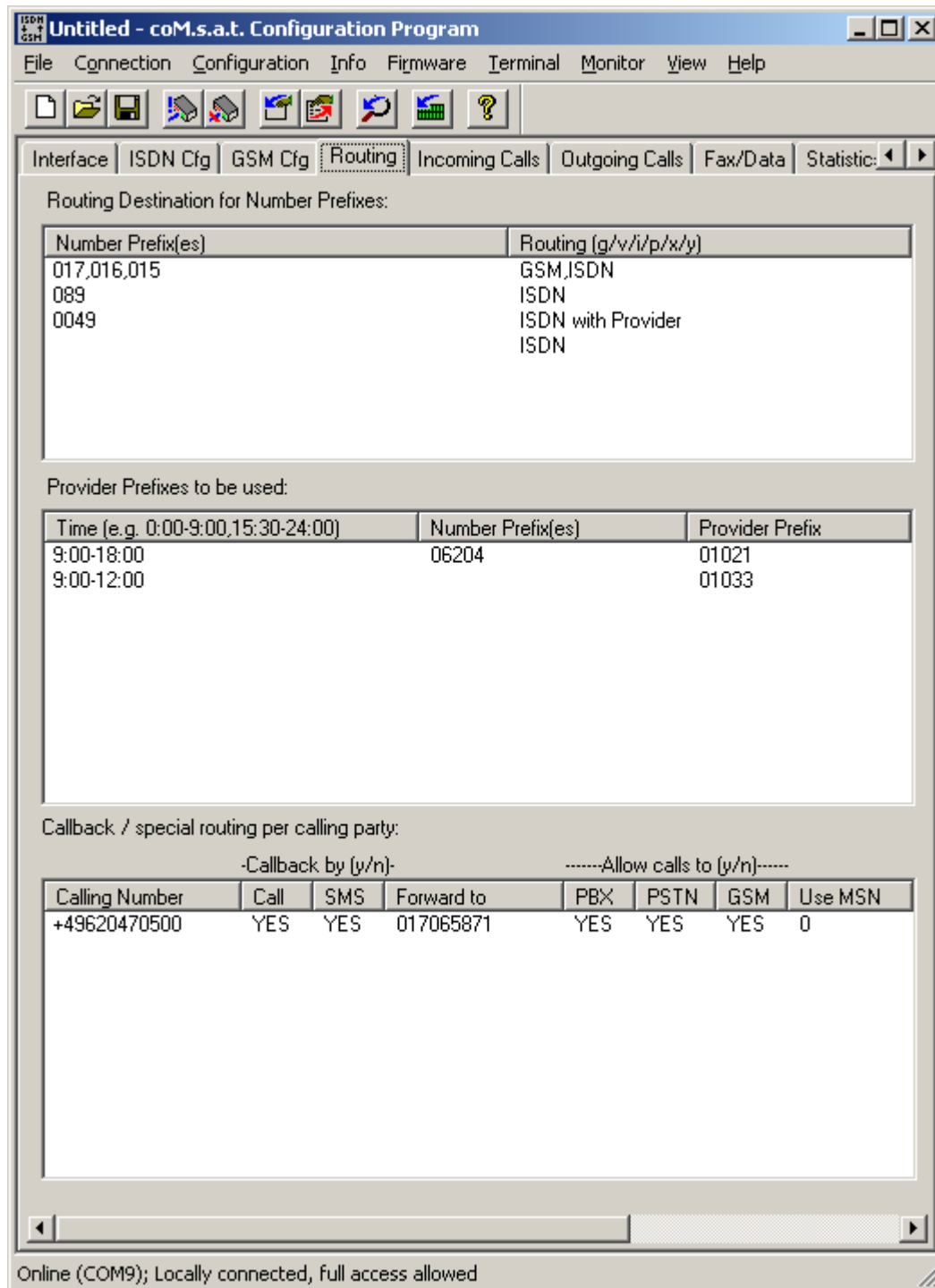

Figure 10: Routing

3.3.4.1 Routing according to dialled number

The table “Routing Destination for Number Prefixes“ determines if GSM (with or without provider) or ISDN (with or without provider) is to be used. Special cases also require the setting of a routing for calls to the PBX (with or without provider).

Example:

Number Prefix	Routing
017, 016, 015	GSM, ISDN
089	ISDN
0049	ISDN with Provider
	ISDN

This table is parsed from top to bottom, comparing the prefix with the called number. If the number’s first digits match the given prefix, the routing is evaluated. If “GSM” is specified, a GSM channel is selected according to the “Net Access Numbers“ settings, optionally inserting a provider. If “ISDN” is specified, the call is routed to PSTN, again allowing the insertion of a provider prefix, just like the specification of “PBX” which causes a routing to the TC system. If more than one route is specified and the first one is not able to route to call, the second option is evaluated. If e.g. “GSM,ISDN” is specified and there is no GSM channel available at the moment, the call is routed to ISDN (“fallback”). If in this case only “GSM” would have been specified, the call would be rejected.

The example above causes the following behaviour:

- All calls to typical (german) GSM numbers are routed via GSM if possible, and via ISDN otherwise
- All calls to Munich (089) are routed via PSTN without provider prefix
- All other calls to german numbers (+49) are routed via PSTN with a provider prefix
- All other calls are routed via PSTN without provider

In addition to numbers, the place holder “?” can be used to specify any number. This is especially useful if numbers can only be distinguished by their length. This applies e.g. to internal MSNs and local area numbers. The following example assumes that all internal MSNs are two digits long:

Number Prefix	Routing
017, 016, 015	GSM
???	ISDN
??	PBX

This routing table works like this: All GSM numbers are routed via **GSM**. If any number with only two digits is dialled, only the entry number 3 matches, because all other entries require at least 3 digits. All numbers with more than two digits not matching the first line are routed to the ISDN network.

The table is split into two columns and the entries are directly edited in the list box. A double click on an entry makes it editable. By using the “Page Up” and “Page Down” keys, the edit field can be moved to the next or previous column. The cursor up and down keys move the edit field one line up or down in the same column.

If the list box has the input focus but no entry is edited, the insert key allows to create a new line above the first currently selected line. All selected lines can be deleted using the delete key. Ctrl-C copies selected lines to the clipboard just like Ctrl-X which also removes the lines afterwards. Ctrl-V inserts lines from the clipboard above the first selection or at the bottom of the table if none is selected. A selection can be removed by left click with pressed control key as usual in multiple selection list boxes. Tab and shift-tab can be used to jump to the next or previous dialog element, as usual.

The second column only allows to use the keys “i”, “g”, “p”, “v”, “x”, “y”, backspace, cursor left/right and delete. “i” inserts “ISDN”, “g” inserts “GSM” and “x” inserts “PBX” at the current insert position. “p”, “v” and “y” do the same with the option of inserting a provider prefix. The cursor can only be positioned at the beginning and end of words. Delete and backspace always delete complete words.

Empty lines are removed automatically before the configuration is updated.

3.3.4.2 Selection of providers by time and number

The table “Provider Prefixes to be used“ defines which provider should be used for those numbers that are routed with provider specified in the first table. This table is ignored otherwise.

Example:

Time	Number Prefix	Provider Prefix
9:00 – 18:00, 20:00 – 22:00	0241,0621	01021
9:00 – 12:00		01033
12:00 – 18:00		01013
18:00 – 20:00		01051
0:00 – 24:00		01070

This table is parsed from top to bottom, comparing the current time to the times specified in the first column and the called number to the prefix in the second column. An empty entry in the number prefix column matches any number. If both entries match, the provider specified in this line is used.

The first line in this example defines a specific prefix for specific area codes. The last line in this example causes all numbers not matching one of the entries above to be routed using the prefix 01070.

If no entry matches, the call is rejected.

This table is displayed in three columns that are edited the same way as the first table, except that there is no special editing as in the second column of the first table.

3.3.4.3 Callback Table and special routing

The last table on this page, which is only activated if there is a valid Basic Pro license (see 3.3.15), allows to call back special GSM numbers on request. The callback can be initiated either by a call (which is rejected) or by an SMS, depending on which method is allowed in the columns "Call" and "SMS" by entering "yes". If a callback by SMS is allowed, it is sufficient to receive an SMS from that GSM number. If the SMS contains a number, it is stored as desired number to be called.

If the callback is accepted by the GSM user, he usually gets a dial tone and can dial a number to one of the allowed destinations. If the channel used does not allow dialling ("Call Default"), there is no dial tone and the call is forwarded to the number configured in column "Forward to". If the callback was done due to a received SMS and the SMS contained a number, there is no dial tone either and that number is called.

If one (and only one) line has an empty "Calling Number", this line matches any call without CLIP. These callers never get a dial tone but are always forwarded to the number configured in column "Forward to".

This table can also be used to configure a default number different from that in the channel settings. The number configured in column "Forward to" supersedes the number of the channel settings and is called if that special GSM user is calling and nothing is dialled or dialling is not allowed. This is also true if no callback is allowed, so that the entry only assigns a different default number.

Additionally, the table can prevent certain callers from calling specific destinations. If a calling party number matches an entry in the callback table, those destinations in the routing table not allowed by this entry are removed from the possible routes.

3.3.4.4 Automatically inserted country and area codes

The own country and area code is programmable on the dialog page named "ISDN Cfg". This enables the router to find matches in the tables even if the table entries are specified with these codes and called numbers are lacking them. It is also possible to specify the tables without these codes and called numbers with these codes will still match. This eliminates the need for specifying all possible number representations.

3.3.5 Incoming calls

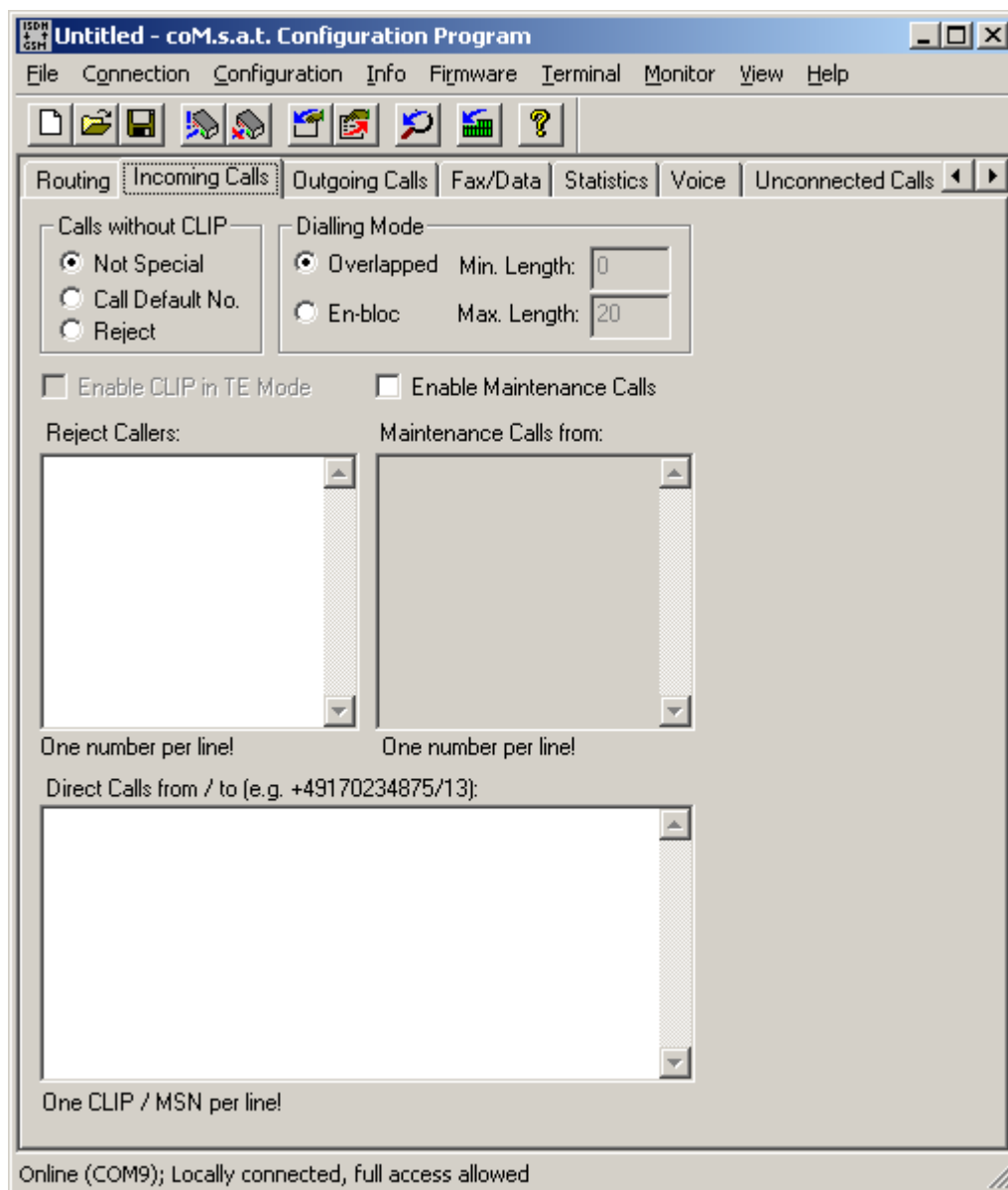

Figure 11: Incoming calls

The configuration for incoming GSM network calls is set up via the “**Incoming calls**” card. First set up how “**Calls without CLIP**” are dealt with. These calls can either be transferred to a particular extension (“**Call Default No.**”), which is determined during configuration of the GSM channels, or **rejected**, or dealt with in the same way as all other calls (“**Not Special**”).

The dial in behaviour on calls from GSM is further specified by the option “**Dialling Mode. Overlapped**” means that incoming calls are immediately reported to the PBX without any dial information. The PBX requests more information and the call is

connected. Each dialled digit is immediately forwarded to the PBX which terminates the dial procedure as soon as it has enough information to call an extension.

This is different if **"En-bloc"** dialling is selected. Then the **coM.sat ISDN Basic** connects the call without contacting the PBX. This is done after the called number has been completely received. Since the device does not know the numbering plan of the PBX, it can not determine from the called digits if a number is complete. This is detected either by having received as much digits as specified by **"Max. Length"** or if no more dial information is received for as long as configured in **"Incoming call dial timeout"** in the channel settings. If less than **"Min. Length"** digits is received, the call is rejected.

The option **"En-bloc"** has to be used if the PBX does not support overlapped dialling. If no PBX is connected, but only some phones on a bus, this is almost always necessary. If using overlapped mode and incoming calls which should be able to dial do not get a dial tone, but one or more phones start ringing immediately, this indicates that the **"En-bloc"** option is needed.

A further option (**"Enable CLIP in TE Mode"**) can also be selected in this card, but it can only be accessed if the TE mode has been set. You can then choose whether the caller's number is to be transmitted or not. If this box is checked, the **coM.sat ISDN Basic** tries to transmit the number calling from within the GSM network - provided the telephone system it is connected to supports this feature.

The option **"Enable Maintenance Calls"** determines the handling of GSM data calls. If the option is switched off, all data calls are ignored. If it is enabled, these calls can be connected in order to perform remote maintenance. If the list **"Maintenance Calls from"** is empty, all data calls are connected. If there are numbers in this list, only data calls from these numbers are connected for remote maintenance.

Callers can also be rejected by the **coM.sat ISDN Basic**. The relevant phone numbers are entered in the **"Reject Callers"** list box. Only one phone number is entered in each row. The number of the caller may be longer than the number in the list, so multiple callers with the same prefix can be rejected with a single entry.

The telephone numbers of callers that are to be transferred directly to specific extensions can be entered in another list (Direct Calls from / to). The callers must have activated Calling Line Identification Presentation (CLIP) in their phone in order to utilise this feature. The entries must be entered in the form: <international phone number><national dialling code><phone number>/<MSN>.

Example: +4962171481430/22

Note: Both lists use the country and area code settings so that only one notation of a number need to be entered in the lists.

The length of the lists only depends on the amount of internal memory. A storage area of 32 kByte is available for the lists and configuration parameters. A 10 - digit number occupies 10+1 bytes of memory, moreover a few additional bytes are needed for the termination of the lists. It is up to the user to decide which lists are important and need to be enforced. It is entirely possible to use one and only one of

the definable lists with the maximum length or to use all lists with an accordingly reduced length. In the latter case the lists each have a length of approximately 70 entries.

3.3.6 Outgoing calls

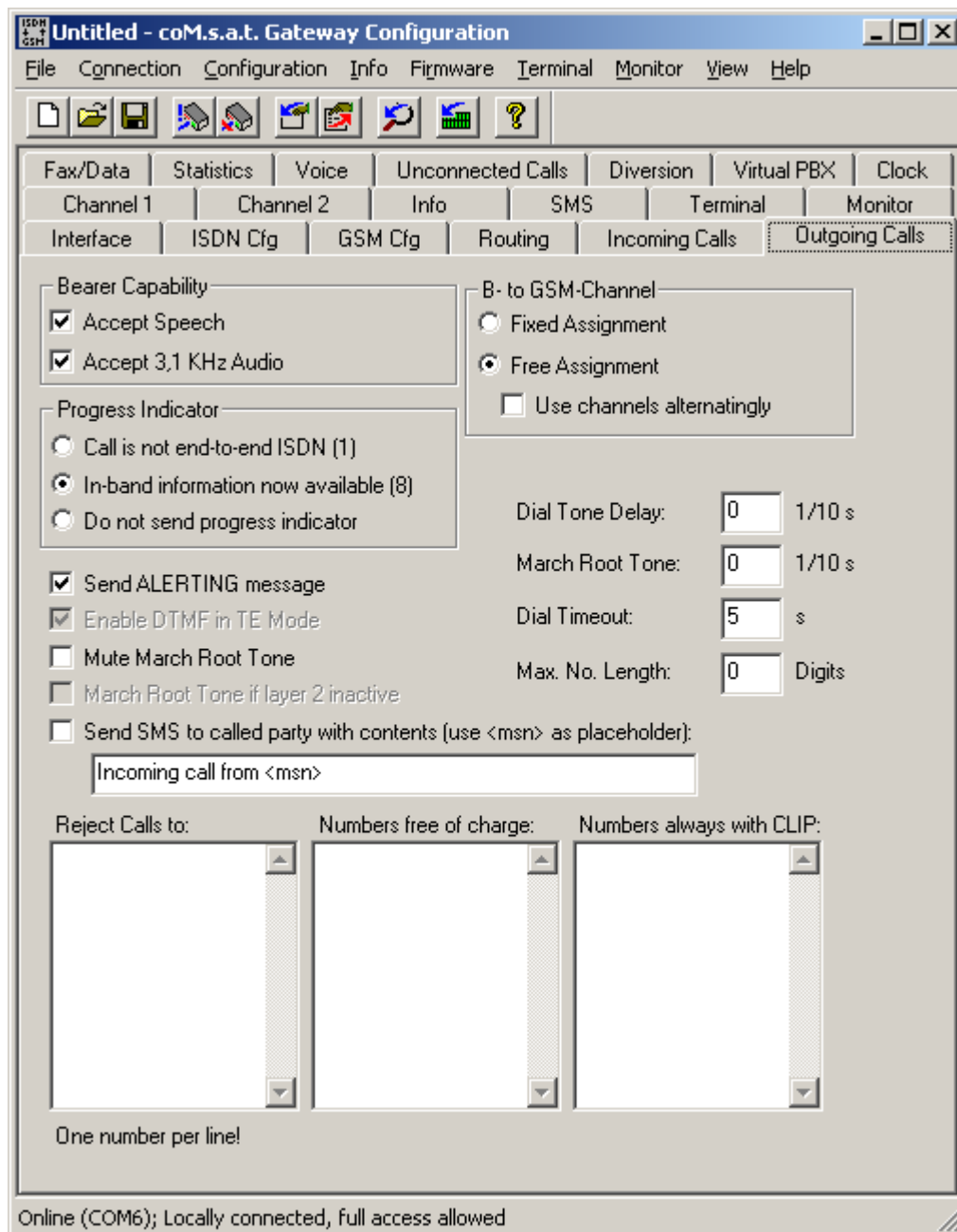

Figure 12: Outgoing calls

A separate card is provided for the configuration of outgoing calls in the same way as for incoming calls.

The type of speech communication is selected in the “**Bearer Capability**” box of this card. The “**Accept Speech**” option should then be selected if the **coM.sat ISDN Basic** is connected to a telephone system to which only ISDN telephones are connected. If analogue telephones are also used, both options should be selected. On the other hand, no speech communication is possible if both options are

deactivated. This makes sense if only SMS is to be exchanged.

The assignment of the B-channels to the GSM channels is then defined in the “**B to GSM Channel**” box. Fixed assignment determines that the first B channel is assigned to the first GSM channel. Fixed assignment of the channels can be useful if e.g. different network providers are to be used for the two GSM channels. If the channels are freely assigned, the call is assigned to the first free channel. If one channel is busy, the other is used. In the case of free channel allocation there is the additional option “**Use channels alternately**”. The GSM channels are selected alternately. This feature can be used to balance the load (the cost) evenly between channels. If this box is not checked, there will be a bias towards one channel!

The “**Progress Indicator**” setting influences the value of an ISDN information element. The first value “Call is not end-to-end ISDN” informs the connected PBX that its call uses a different network to be connected. The other value “In-band information now available” informs the PBX that an announcement or a tone is available and must be transferred to the calling user. This value is usually needed for correct operation, whereas the first value may be needed by specific PBXs. If the progress indicator causes a problem in the PBX, it is possible to switch it off completely with the third option “Do not send progress indicator”.

The “**Dial Timeout**” is the time that may pass between the last digit of the phone number being dialled and the selection process is passed into the GSM network. This time is usually set to 5 secs. It can be reduced to 1 second. The maximum possible setting is 10 secs. The time between dialling the last digit and hearing the dialling tone can be reduced by reducing this time.

Note: In some telephone systems, dialling can also be concluded by pressing the “#” key. In this case there is no waiting time.

The “**Send Alerting Message**” option is used to set whether the “**Alerting**” message is generated by **coM.sat ISDN Basic** for calls to PBX. If this option is selected, the “**Alerting**” message is inserted by **coM.sat ISDN Basic** for an outgoing call after the “**Setup**”. If the option is not activated, the “**Alerting**” message is suppressed and the call is continued with “**Call Proceeding**”. Use of this option also depends on the properties of the connected telephone system.

coM.sat ISDN Basic always generates the dialling tone (exchange dialling tone) itself and transfers the ringing tone or the network provider announcements to the B-channel. Whether the ringing tone or the network provider announcements from the GSM network are used in the B-channel or the ringing tone generated by the telephone system is used now depends on whether the “**Alerting**” option has been activated or is passive.

The “**Enable DTMF in TE Mode**” option must be used if the **coM.sat ISDN Basic** is connected to a PBX in TE mode which does not support overlapped sending of dial information (which is the usual case). Then the GSM number is dialled with the aid of DTMF tones.

The “**March Root Tone**” serves to bridge delays with a tone or sequence of tones in order to prevent the impression that the line is “dead”, particularly during the call setup. The TC35i modules produce the “march root tone” on their own. If the tone of

the ISDN Basic is to be used, the tone of the TC35i module should be switched off. The duration of the tone is set in the input box: 30 represents a tone of 3 seconds duration.

The parameter "**Dial Tone Delay**" can be used in applications that rely heavily on block dialling. Some PBXs do block dialling in two steps. First they initiate a call without number so that the ISDN Basic generates a dial tone. Then they send the called party number which stops the dial tone again. This can be prevented using "**Dial Tone Delay**", delaying the dial tone by multiples of 0.1 seconds. The dial tone is only started if no dialled number is received during that time.

If the GSM network always uses the same length for its phone numbers, the parameter "**Max. No. Length**" can be set to this length. This instructs the **ISDN Basic** to start the outgoing call immediately after that number of digits have been dialled, without waiting for timeout.

The March-Root-Tone generated by the TC35i module can be suppressed by checking "**Mute March Root Tone**".

The option "**Send SMS called party...**" causes an SMS to be sent for calls from PBX to GSM containing a configurable text where the MSN of the caller can be inserted using the placeholder <msn>. This allows the called user to see who calls him during an active or after a missed call.

The possible settings for outgoing calls are then rounded off by three lists.

The phone numbers that are not to be dialled are entered in the first list, e.g. very expensive numbers that start with 0190x. If no country and area code is specified, the phone number must be entered both with and without the dialling code to avoid being able to call restricted numbers by using or omitting these codes.

Example: 71481430
 062171481430
 +4962171481430

However, if the country code "+49" and the area code "0621" is configured, only one entry of the three above is necessary.

The comparison of the numbers begins at the first position and need not match completely. Entries in this list can therefore be prefixes.

The second list is used for entering the phone numbers that allow free calls, e.g. the numbers that begin with the digits 0800. No charge impulse information is generated for these numbers. The notes above also apply to this list.

The third list contains numbers or prefixes that shall always see the calling party number when called (CLIP), even if this function is disabled (CLIR is enabled) for the calling channel. This allows to enable CLIP and return call handling for specific numbers (see 3.3.10).

3.3.7 Fax/Data

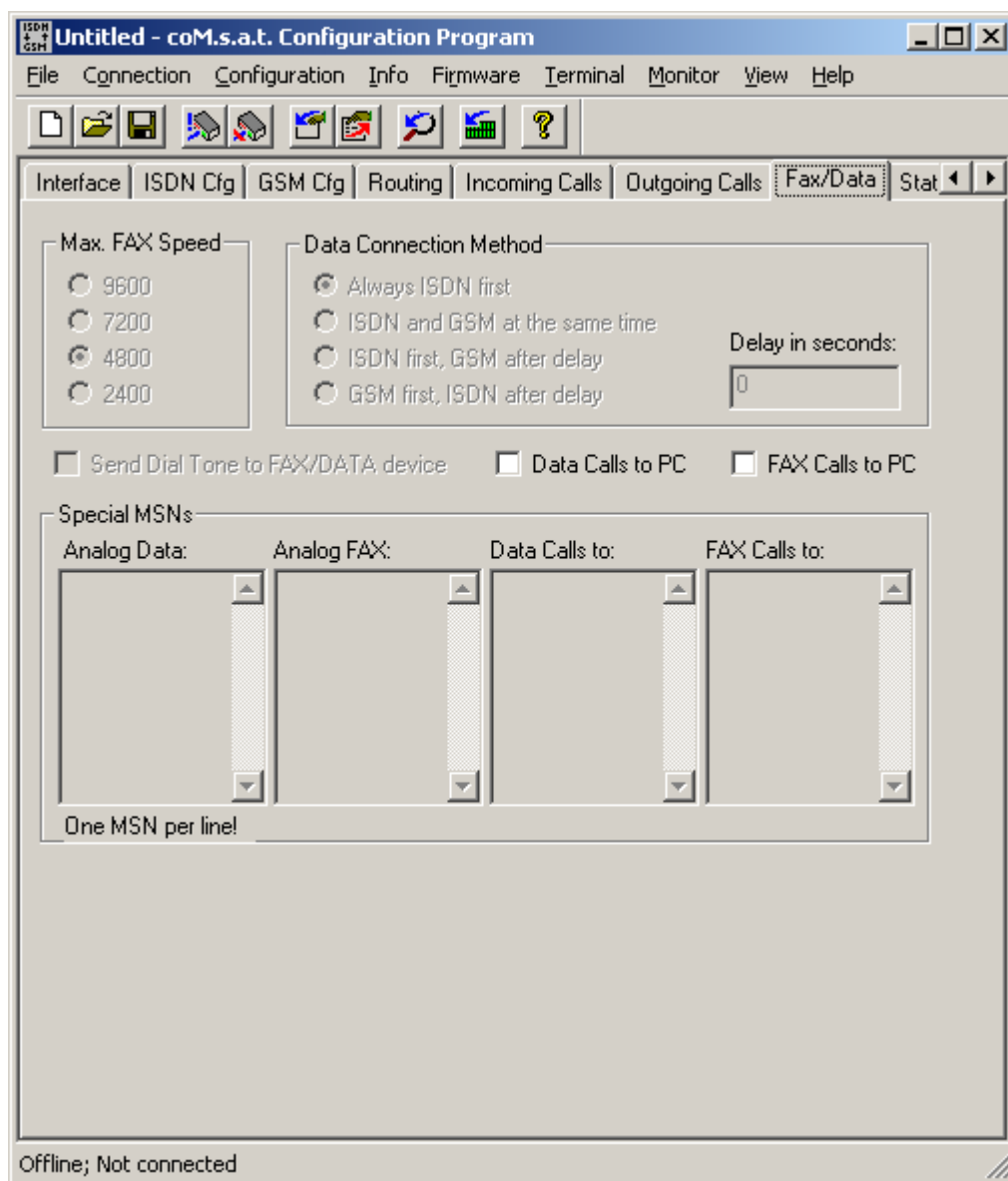

Figure 13: Fax/Data

This page allows the configuration of data and fax connections. Since the **coM.sat ISDN Basic** has no built-in analogue modem, it is not possible to set up data or fax connections via ISDN and therefore the options for these kind of calls are disabled.

The **coM.sat ISDN Basic** is able to exchange data and faxes by the use of a PC. In this case, the connected PC must have suitable software for fax or data which is ready to receive incoming calls. To enable this, "**Data Calls to PC**" and/or "**FAX Calls to PC**" must be enabled. Then the **coM.sat ISDN Basic** behaves like an analogue modem on its serial interface, i.e. incoming calls are reported with a "**RING**"

indication. Following commands and data are directly transferred between PC and GSM module so that it behaves as a fax class 1 modem for the PC.

Outgoing fax and data connections are always possible via the serial interface without special configuration. If the dial command (ATD) is detected, this command is given to a free GSM module regarding the net access numbers, and this module is connected transparently to the PC, so that the PC again operates as if connected to a fax class 1 modem. If the PC sent other commands immediately before the dial command which are not processed by the **coM.sat ISDN Basic** itself, these commands are also sent to the GSM module before dialling. Further information on fax and data connections can be found in chapters 4.5 and 4.6.

Note 1: The SIM cards used must support fax and data calls.

Note 2: If fax and/or data shall be exchanged with the use of a PC, but the PC software did not activate the serial interface, these calls will be rejected.

3.3.8 Statistics

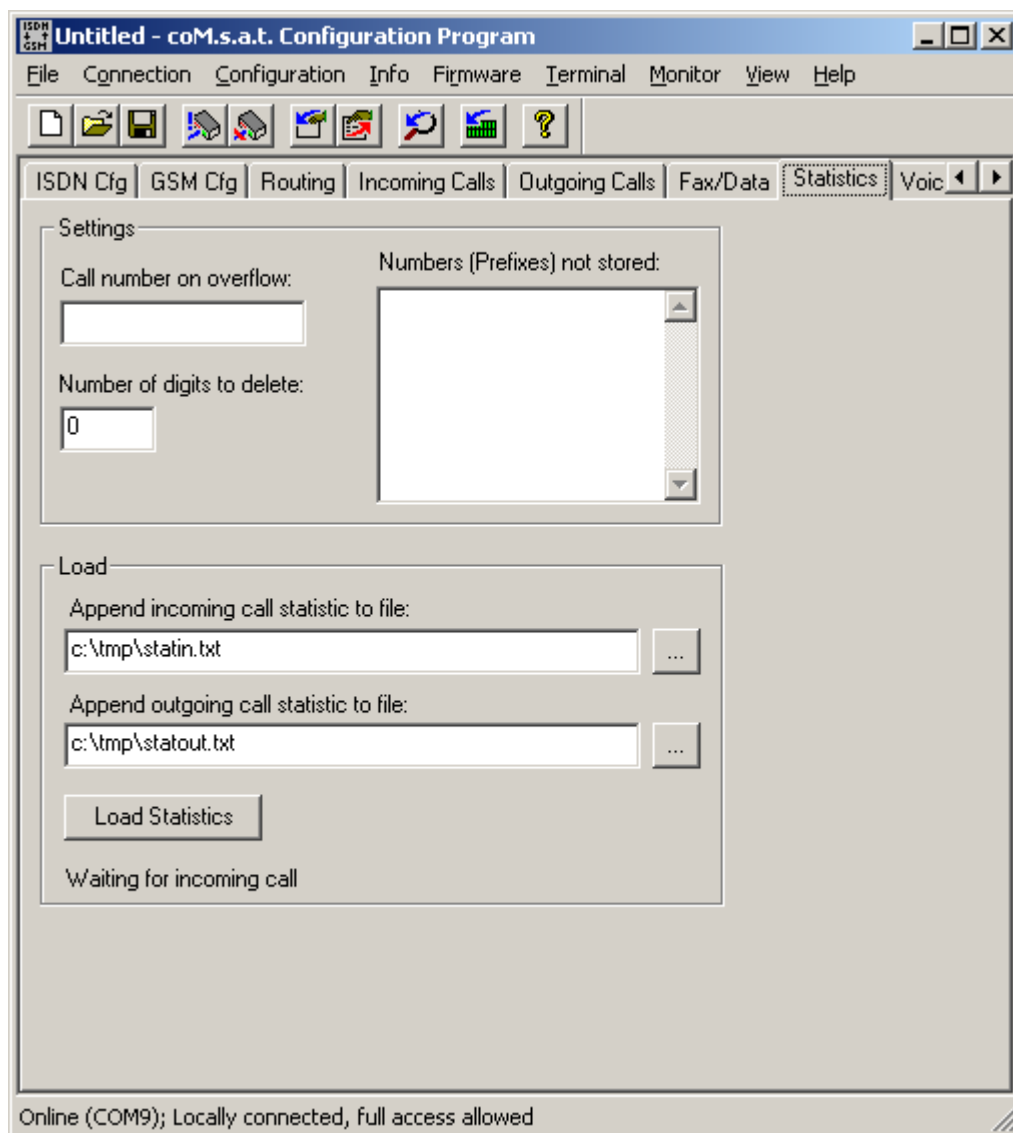

Figure 14: Statistics

The statistic functions are intended for the storing of call data. Incoming and outgoing calls are registered. The information is stored in two different files. Due to the limited memory space, call data is stored until the available memory is almost used up. When it becomes obvious that memory will shortly be full, a data call is set up to the pre-defined number which is set under "**Call number on overflow**". This must call a GSM modem (e.g. another **coM.sat ISDN Basic** in transparent mode, see 3.3.18) in a central office that is equipped with a SIM card allowing data transmission. There must be a PC running **coMsat.exe**, which is in contact with the GSM modem over a serial interface and which has the statistics page opened. This enables it to react on incoming calls (RING). In this case the call is accepted, the statistics read out and the call terminated again. The current action is displayed beneath the "**Load Statistics**"

button, e.g. "Waiting for incoming call".

The call data can be read out manually by clicking the "**Load Statistics**" button. The read-out data is stored on the PC in predefined files. New data is appended to existing files. Outgoing call data are written to the file set in the "**Append outgoing call statistic to file**" box. Incoming call data are written to the file set in the "**Append incoming call statistics to file**" box. In order to ensure protection of data security, two measures are implemented. On the one hand phone numbers and prefixes not to be stored at all can be defined in the list "**Numbers (Prefixes) not stored**". On the other hand the stored numbers can be truncated by a defined number of digits set in "**Number of digits to delete**".

The read-out data is stored in such a way as to easily process them with standard spread sheet applications such as Microsoft Excel® as follows:

Incoming: Calling number, Date, Time, Duration, Internal Number

Outgoing: Called number, Date, Time, Duration, Internal Number

The "Internal Number" represents the originating or terminating extension.

Note: The statistics function is only activated if there is a valid Basic Pro license (see 3.3.15).

3.3.9 Voice

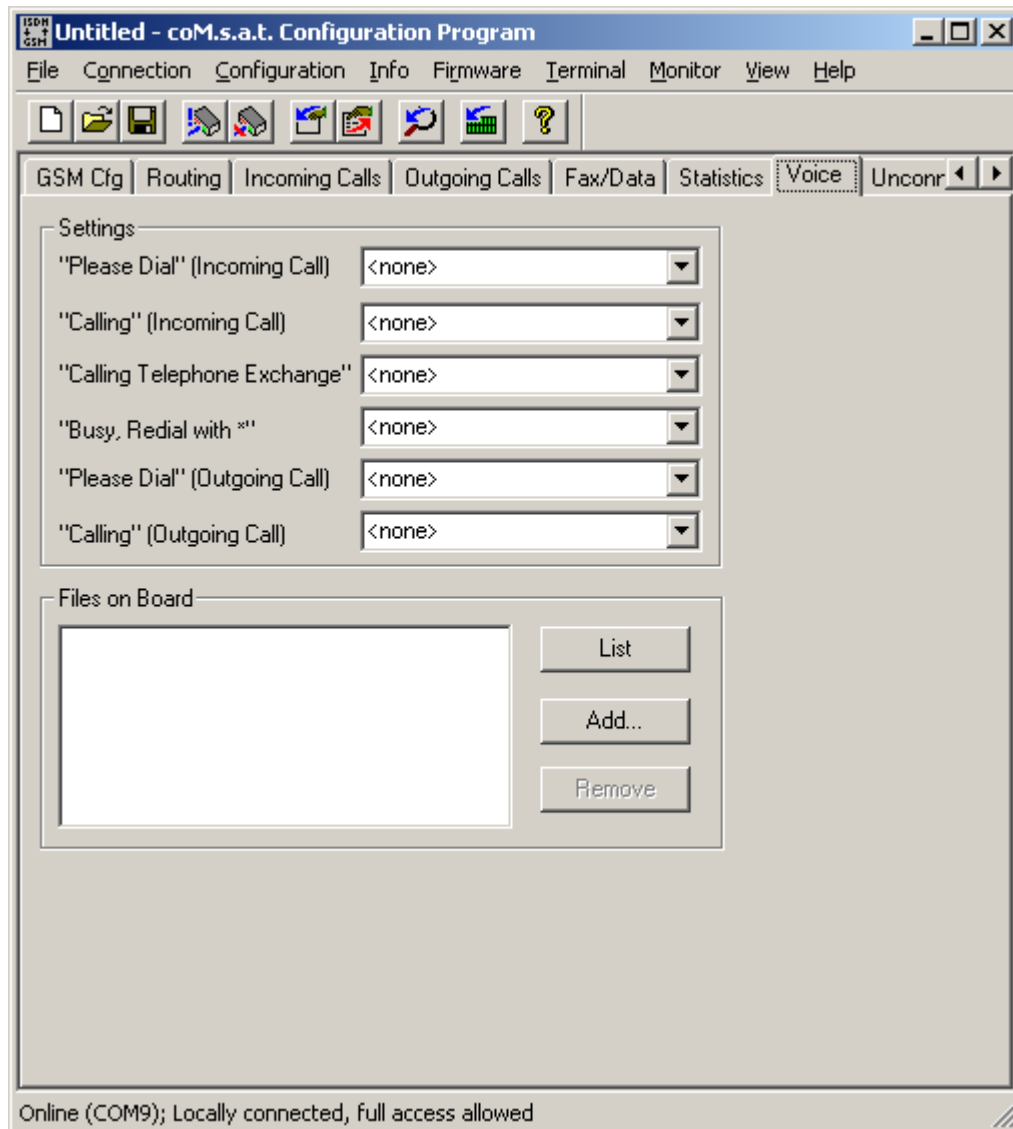

Figure 15: Voice

In certain operating situations voice announcements can be blended in to inform the user during call build-up or forwarding. 6 different announcements can be stored in the **coM.s.a.t ISDN Basic** memory. These messages are intended for the following situations:

1. On incoming calls, the caller can be informed to dial the extension number ("**Please dial (Incoming Call)**").
2. On incoming calls, the caller can be informed that the desired subscriber's extension is called ("**Calling (Incoming Call)**").
3. On incoming calls, the caller can be informed that the default number is called ("**Calling Telephone Exchange**").

4. On incoming calls, the caller can be informed that the desired subscriber's extension is busy and that he can dial again after "*" ("**Busy, redial with ***").
5. On outgoing calls, the caller can be informed that to dial ("**Please dial (Outgoing Call)**").
6. On outgoing calls, the caller can be informed that the desired destination is called ("**Calling (Outgoing Call)**").

Regarding all announcements, please note that these may altogether be no longer than 60 seconds due to the limited memory space. Furthermore these announcement .wav-files must be stored in the **CCITT A-Law format** with 8 bits and mono recording at 8000 samples per second. Wav-files with the announcements are assigned to the appropriate situations and/or functions by the input boxes.

The list box in the lower part of the tab displays the files loaded into the device. The display can be updated by clicking the "**List**" button. The "**Add**" button adds further files. The "**Remove**" button enables single files to be deleted. This button is only active if files have been loaded previously and a file is selected.

Note: The voice announcements are only activated if there is a valid Basic Pro license (see 3.3.15) and the device contains larger memory.

3.3.10 Unconnected Calls

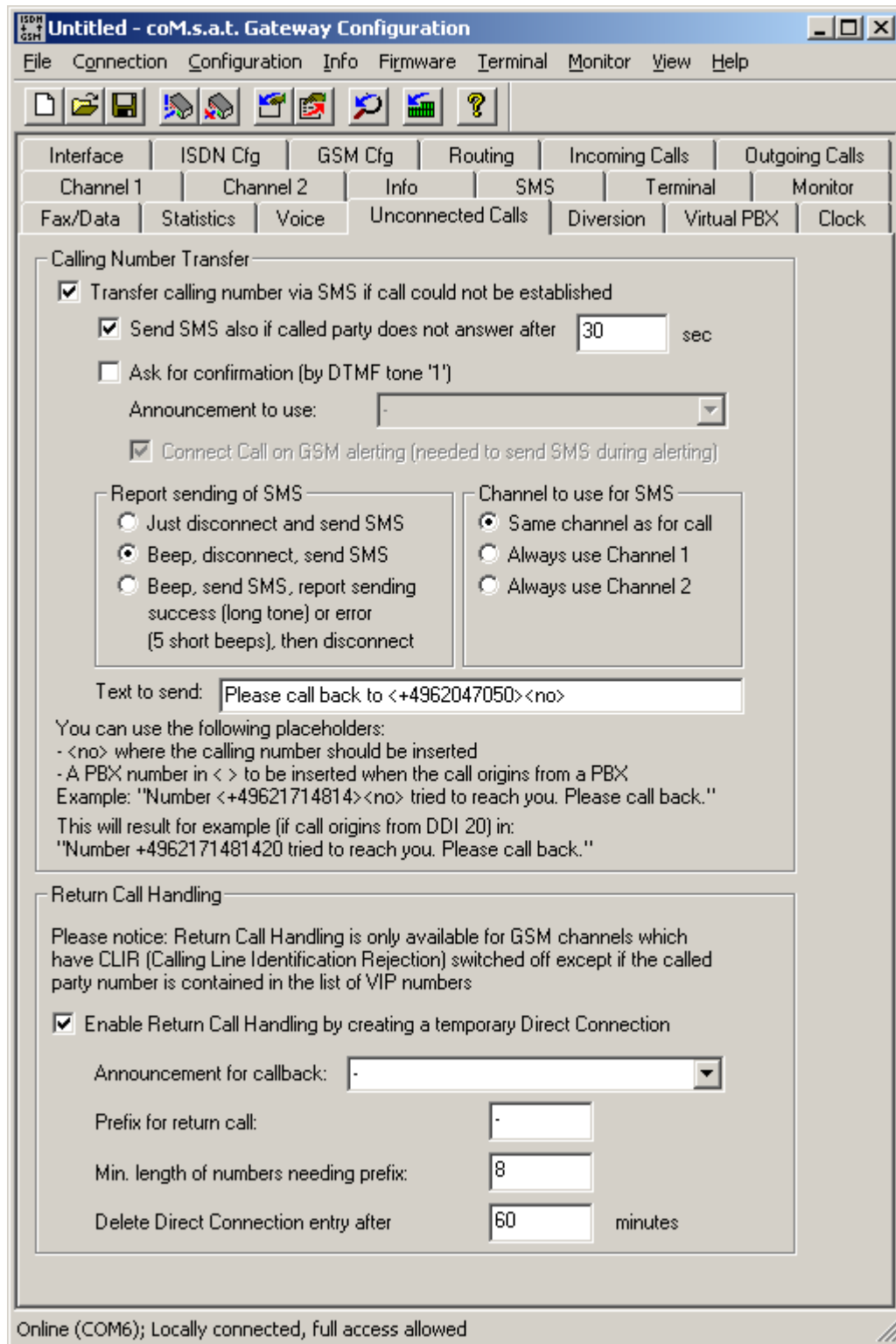

Figure 16: Unconnected calls

The settings on this page solve the following problem:

When using a GSM gateway the calling party number can not be transferred to the called party, but he sees the number of the SIM card of the gateway (if CLIR is switched off, else none at all).

On one side this is inconvenient for the called party because it can not decide whether to accept the call or not.

On the other side a problem occurs when the call is not accepted, or the called party is busy. In this case it is not possible for the calling party to wait for a return call, because the called party has no information about the calling party number.

It would be possible to transfer the number of the used GSM module so the called party could make a return call and be connected to the PBX. This is of little use because the caller has no information concerning the DDI from which he was called, so he could only be forwarded to the default number.

To overcome this problem, two strategies are possible, depending on whether the CLIR of the calling GSM channel of the gateway is activated or not.

The "**Calling Number Transfer**" settings activate the sending of an SMS to the called user who could not be talked to. This SMS contains a text and additional information on the number to call back. This additional information has the following syntax and meaning:

<callback number><no>
callback number: The head number of the PBX
no: Extension number

Example:

The following text has been entered for the SMS:

"Please call back to <+4962047050><no>"
(Do not enter the quotation marks)

If the caller calls from extension 18, the called user gets the following SMS:

"Please call back to +496204705018"

The time after which an SMS is to be sent if the called party does not answer can be configured. If e.g. the called party does not answer within 30 seconds, the call is terminated and the SMS sent. If the called user rejects the call or is busy, this happens immediately.

The sending of the SMS can optionally be done only after confirmation by the caller, not automatically. To configure this, the option "**Ask for confirmation**" must be activated. Then the SMS is only sent if the caller sends the DTMF tone of digit 1. Then it is additionally possible to configure an announcement that asks for the confirmation instead of only playing a tone.

In addition, confirmation tones can be sent to the caller depending on the setting of "**Report sending of SMS**".

The **"Return Call Handling"** settings control the processing of a callback of the user that was not reachable. When a call to a GSM party can not be established, the gateway stores the called party number together with the calling party number (normally an extension of the PBX) in a list.

When a call comes in from GSM the gateway looks for the calling party number in this list. If an entry is found, the call will be directly connected to the stored extension. The duration that an entry should remain in this list can be configured with the option **"Delete direct connection entry after"**. If there is no callback within this period, the entry in the list is deleted.

The user who calls back can optionally hear an announcement telling him that he is directly connected to a user who tried to call him. To achieve this, the option **"Announcement for callback"** must be set to a programmed announcement. If it is, the user calling back is connected immediately to play the announcement and therefore is charged the GSM fee immediately even if the called user does not answer the phone. If no announcement is set, the GSM call charging will start only if the called user accepts the call.

For the return call, it is possible to insert a prefix in front of the called number (that was the calling number during the first call) by specifying the prefix in the field **"Prefix for return call"** and setting a minimum length in the field **"Min. length of numbers needing prefix"**. This instructs the device to insert the prefix only if the called number has at least that amount of digits. This enables to handle return calls that were routed from PSTN to the ISDN Basic via a PBX. These calls, which have longer calling party numbers than internal callers, must have the PSTN prefix (usually a '0') inserted when called back so that the PBX routes the call to PSTN, while internal callers are called without prefix.

If the first called party was a VIP and the VIP calls the device, he is still able to dial any number in contrary to other users. This enables a VIP to still use the device as all the time without the need to make the return call. If the VIP wants to make the return call, he can do this by dialling '#' instead of a number.

Every called party number can only be once in the list. A new call to this number overwrites an older entry.

If both options are activated, the Return Call Handling has precedence because it causes not costs. Only if this option can not work because CLIR is activated, the Calling Number Transfer procedure is invoked.

Note: This function is only activated if there is a valid Basic Pro license (see 3.3.15).

3.3.11 Diversion

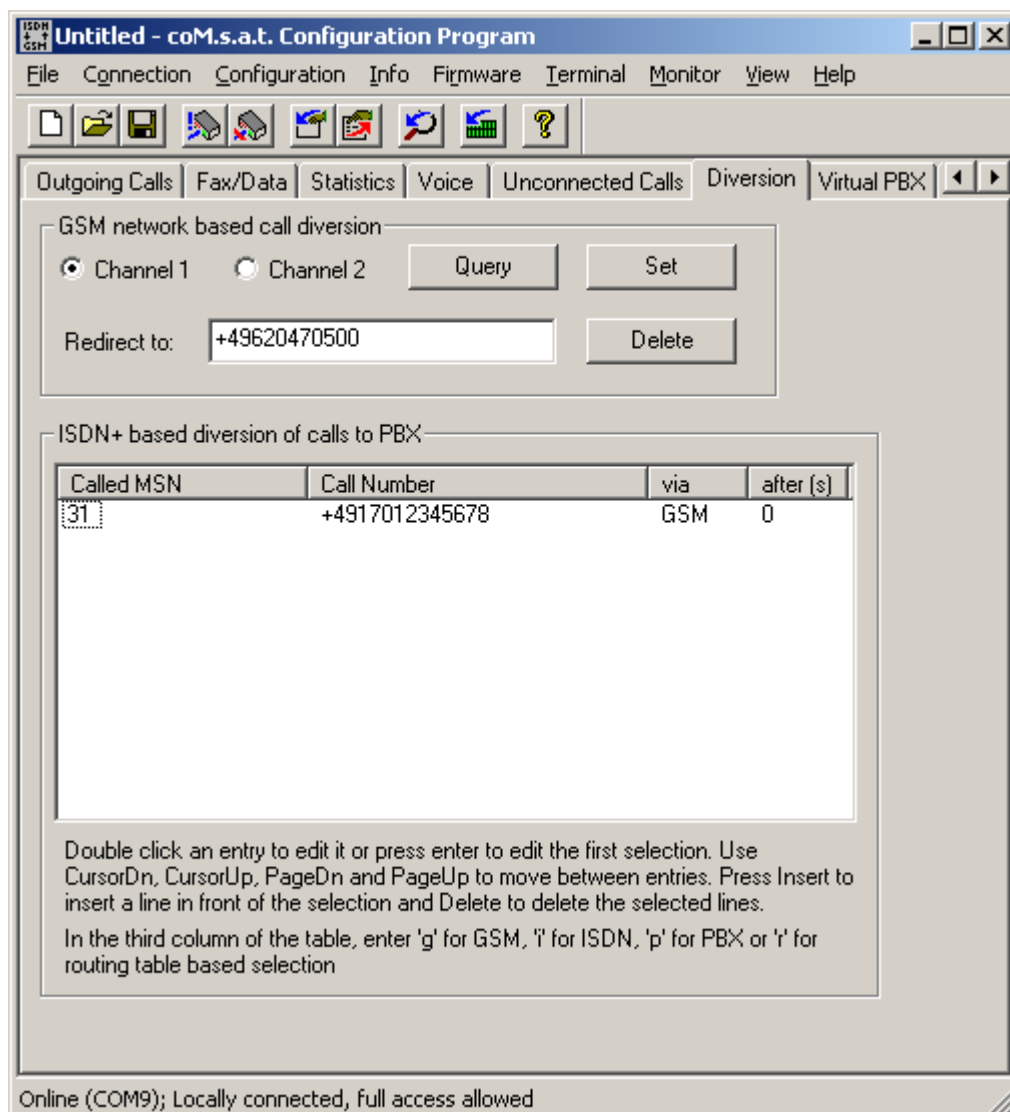

Figure 17: Diversion

On this page, two types of call diversion can be programmed: Call diversion inside the GSM network and call diversion inside the **coM.sat ISDN Basic**.

The call diversion inside the GSM network causes the network to call a different number if the dialled number is busy or unreachable. This kind of diversion allows e.g. if there is a diversion from channel 1 to channel 2 to always call channel 1. If that channel is already in use, channel 2 will be automatically called and the caller need not set up a second call manually.

First the channel to work with must be selected (select "**Channel 1**" or "**Channel 2**"). The button "**Query**" instructs the device to query the currently active call diversion from the GSM network. This procedure needs a data exchange with the GSM

network as all three functions so that it may take 20 seconds or more. As a result of the query, the number redirected to is shown in field **"Redirect to"** or a message reports that there is no diversion. To program a diversion, first enter the number that is to be redirected to and then push the button **"Set"**. About 20 seconds later, the positive or negative operation result is displayed. Pressing the button **"Delete"** causes the call diversion to be deleted.

The second possible call diversion by the **coM.sat ISDN Basic** offers the possibility to call a different number immediately or after timeout if a specific MSN is called. For each diversion, an entry must be programmed in the table that contains the called MSN, the number to redirect to, the route to be used and the duration of the alerting before redirecting. The MSN must be programmed without PBX number. The redirected call may use GSM, fixed network or PBX as destination or the destination can be determined by the routing table. This is programmed with the shortcuts "g", "i", "p" or "r", which are automatically expanded in the table. The timeout may be set to 0 which means the call shall be redirected immediately. If the value is not 0, it determines how many seconds the original extension is alerted before the call is redirected.

It is possible to program multiple redirections for a single MSN. To do this, simply enter one line for each redirection all with the same MSN. These lines are processed from top to bottom, i.e. the first entry is used as first redirection. If that redirected number also does not accept the call, it is redirected to the number in the next entry. Keep in mind that in this case, a timeout of 0 (immediate redirection) may only be used for the first entry. Following redirections only make sense if they are alerted for some time before redirected again.

If a called number is busy and there is a diversion programmed, the redirection is immediately started after it is reported busy.

Note: This function is only activated if there is a valid Basic Pro license (see 3.3.15).

3.3.12 Virtual PBX

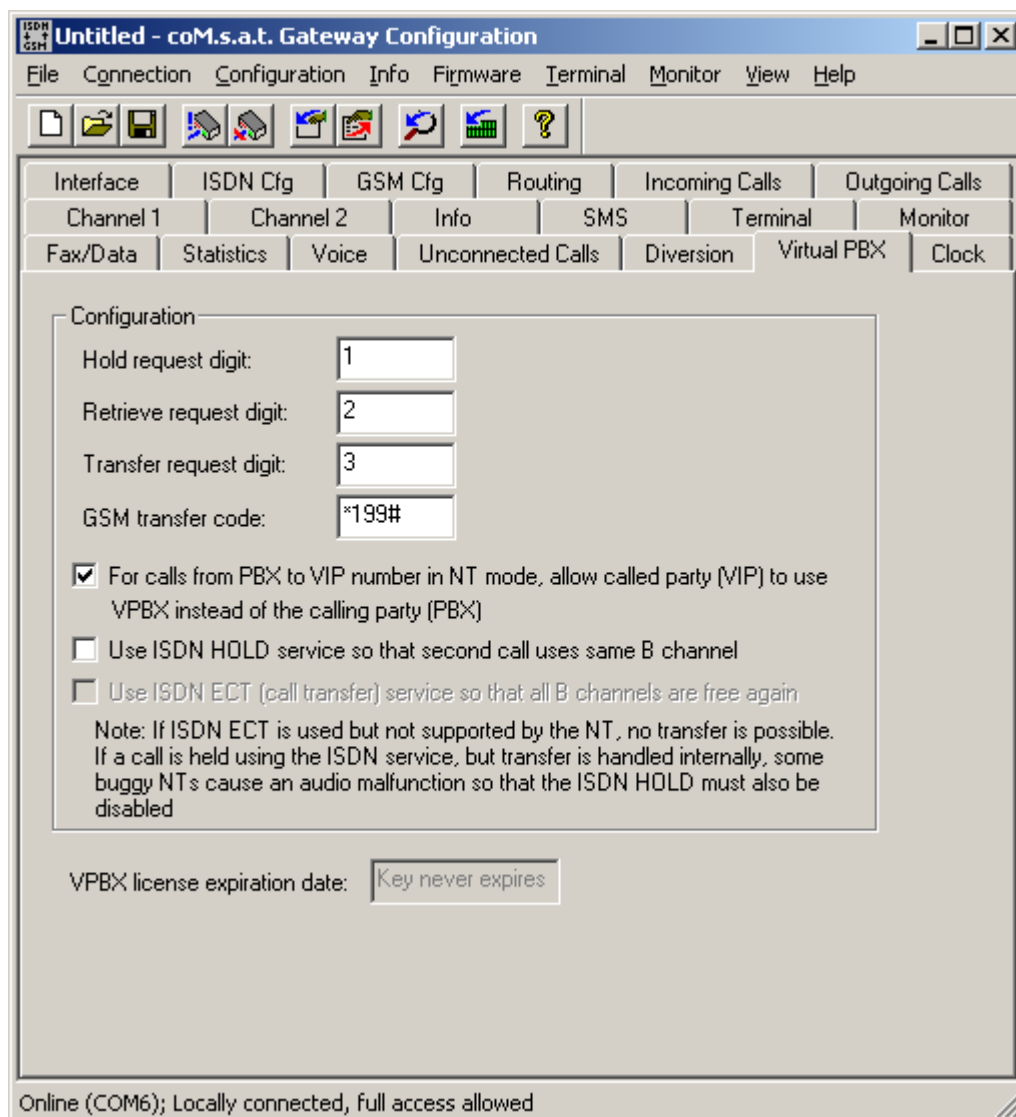

Figure 18: Virtual PBX

3.3.12.1 General Information

The virtual PBX features extend the gateway functionality by the supplementary services:

- call hold
- call retrieve and
- call transfer.

It can be used in combination with a dedicated PBX system or as a standalone solution. Unlike standard PBX applications the virtual PBX allows to configure GSM callers to be handled as internal callers (see also 3.3.3), so that also the GSM caller

can benefit from the supplementary services. Therefore the virtual PBX feature is also useful even if there is already a PBX available.

The virtual PBX functionality is only available if a special license is obtained. The license is set by the command **"Set License"** in the **"Info"** menu (see 3.3.12.6) and if available, its status is displayed below the VPBX configuration.

The supplementary services are invoked by dialling preconfigured digits/signs. Configuration and usage of these services is explained in detail in the chapter "Configuration".

At any time only one of the two connected users is able to invoke the virtual PBX feature:

- If an internal user (internal ISDN user or GSM user configured as VIP) calls an external user, the internal user is able to use the services.
- If two internal users are connected, only the calling user is able to invoke the services.

The second rule can be changed for calls from an internal ISDN user to a GSM VIP user in NT mode. If the last option in the configuration part of the dialog, **"For calls from PBX..."**, is activated, then the GSM VIP user would be able to use the VPBX in such call. This is useful if a PBX is connected to the **coM.sat ISDN Basic** which also implements the VPBX supplementary services. If it is not activated, which is the default setting, then the ISDN user can invoke the VPBX supplementary services. This is usually needed if no PBX is connected.

Please Note: If the device is configured in TE mode, all calls from ISDN are considered to be external calls.

3.3.12.2 Configuration

Three digits need to be specified which are used to invoke the call hold (**"Hold request digit"**), call retrieve (**"Retrieve request digit"**) and call transfer service (**"Transfer request digit"**). All ten digits (0, 1, ...9) and the * or # signs are allowed. It is possible to configure multiple digits, so that an erroneous invoking of a virtual PBX function can be avoided. In this case, the desired function is activated if the configured digits are received in the order specified. The time between the dialling of the digits does not matter.

For transferring a call inside the GSM network, an additional setting, the transfer code, is needed. This is a string containing the digits that would be dialled manually on a cellular phone, followed by the send key (same as hook off). Usually these are three digits with '*' in front and '#' behind them, like **"*199#"**. The network provider supplies this information.

If phones connected to the internal ISDN shall be able to call other internal ISDN phones, it is also necessary to add suitable routing information to the routing table. If e.g. internal phones have the phone numbers 10-29, an entry is needed that indicates local routing of numbers starting with "1" or "2" within the internal ISDN (PBX).

In router mode, a distinction of internal numbers and external numbers that may start with the same digits is needed. Therefore it is possible to distinguish these numbers by length by setting a routing for "1?,2?" to PBX. This entry has precedence if a called party number has exactly two digits.

There are two possibilities to execute hold/retrieve and call transfer. The ISDN Basic can handle the functions internally, or it can issue commands on the ISDN which activate the functions in the net, i.e. externally. The type of execution is selected by the two options "**Use ISDN HOLD...**" and "**Use ISDN ECT...**". Activated options select external, inactive options select internal execution.

The internal operation has the advantage that it always works, independantly of the network. The disadvantage is that the B channel of a held call remains occupied. If external execution is used, the B channel is free to be used by another call, but not all NT connections, especially of PBXs, support these so called supplementary services. Then it is necessary to select internal operation.

An external transfer is only possible if external hold was used. External hold and internal transfer is possible (although not possible on every NT), but causes both B channels to be occupied after the transfer. If one of these B channels is occupied by another call, the transfer is not possible.

The selection of internal or external execution only influences the operation on the TE port. On the NT port, the connected TE chooses to use the ISDN supplementary service functions or the DTMF tones.

3.3.12.3 *Call Hold*

During an active call, dialling the configured hold request digit(s) causes the audio connection to be disconnected. The held user gets a hold tone or announcement (march root tone / calling announcement for outgoing call) while the holding user hears a dial tone or announcement. The user who has invoked the hold function now is able to dial any other number, i.e. an internal or external one. This number is dialled using DTMF tones. During dialling, it is not possible to retrieve the held call, because the retrieve digit would be evaluated as called party number. Only if the new called number is complete and the call proceeds, it is possible to hold (again), retrieve or transfer a call.

When there is a mistake during dialling, terminate dialling by use of the '#' character and hold it again to repeat dialling. It is not necessary to retrieve the held call before holding it again, but it is of course possible (e.g. to notify the calling person).

If the held user is connected via GSM, the call is held using the GSM hold service. The GSM user will hear the network specific call held announcement. If the holding party calls another GSM number, this new call uses the same GSM channel that was used by the first call. This ensures that the second channel is still available for other calls and it also allows to connect the two GSM users inside the GSM network on call transfer without occupying any of the gateway's GSM channels.

3.3.12.4 *Call Retrieve*

A held call can be retrieved if the call to the third party is proceeding or connected. In this case, dialling the preconfigured retrieve request digit(s) causes the third party to be disconnected and the audio connection to the held user to be reestablished.

A connection to the newly called user is not necessary. If the held call is retrieved during alerting, the alerting stops.

3.3.12.5 *Call Transfer*

A held call can be transferred when the call to the third party is proceeding or connected. In this case, dialling the preconfigured transfer request digit(s) by the holding party causes the holding party to be disconnected and the audio connection between the held and the third user to be established. Transfer is also initiated if the holding party hangs up. A connection to the newly called user is not necessary. If the call is transferred during alerting, the alerting continues and the held caller still gets the call held tone.

If the held user and the third user are both GSM users, they get connected by the GSM network internally, and the gateway's GSM channel is available for other calls again.

Note: A GSM network internal call transfer is not offered by all network providers. If it is offered, the service invoke string is not identical for all networks. Therefore it has to be configured properly ("transfer code", see below).

3.3.12.6 *Licensing*

The usage of the virtual PBX feature is only possible with an individual license. To create a license, the IMEI of the first channel is needed. If the configuration tool reads the information (menu "Info", command "Query" or Ctrl-I), it automatically writes the first IMEI to the clipboard. This allows to copy it e.g. into an e-mail instead of typewriting it.

A license consists of four lines of text, e.g.

```
IMEI: 351250005243627
Deadline: 0 (Key never expires)
Key: E69D192E0727D43A670459C724016BD8FC30
Product: Virtual PBX for ISDN Plus/Basic
```

This license can be obtained at coM.sat, e.g. by e-mail. The four lines can be marked in the text and copied to the clipboard (Ctrl-C). The configuration tool reads these lines from the clipboard if the command "**Set License**" in the "**Info**" menu is executed. The following dialog is displayed:

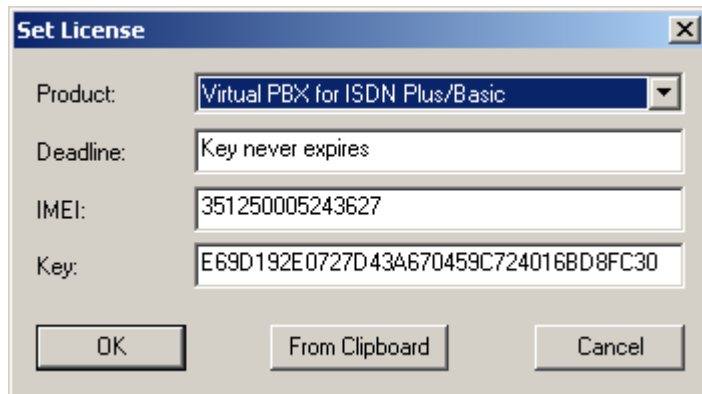

Figure 19: License dialog

If there is no valid license in the clipboard when the dialog is opened, it can be copied to the clipboard afterwards and inserted into the dialog using the button **“From Clipboard”**.

The current license state is displayed below the VPBX configuration, which can be either **“Key never expires”** or the expiration date.

3.3.13 Clock

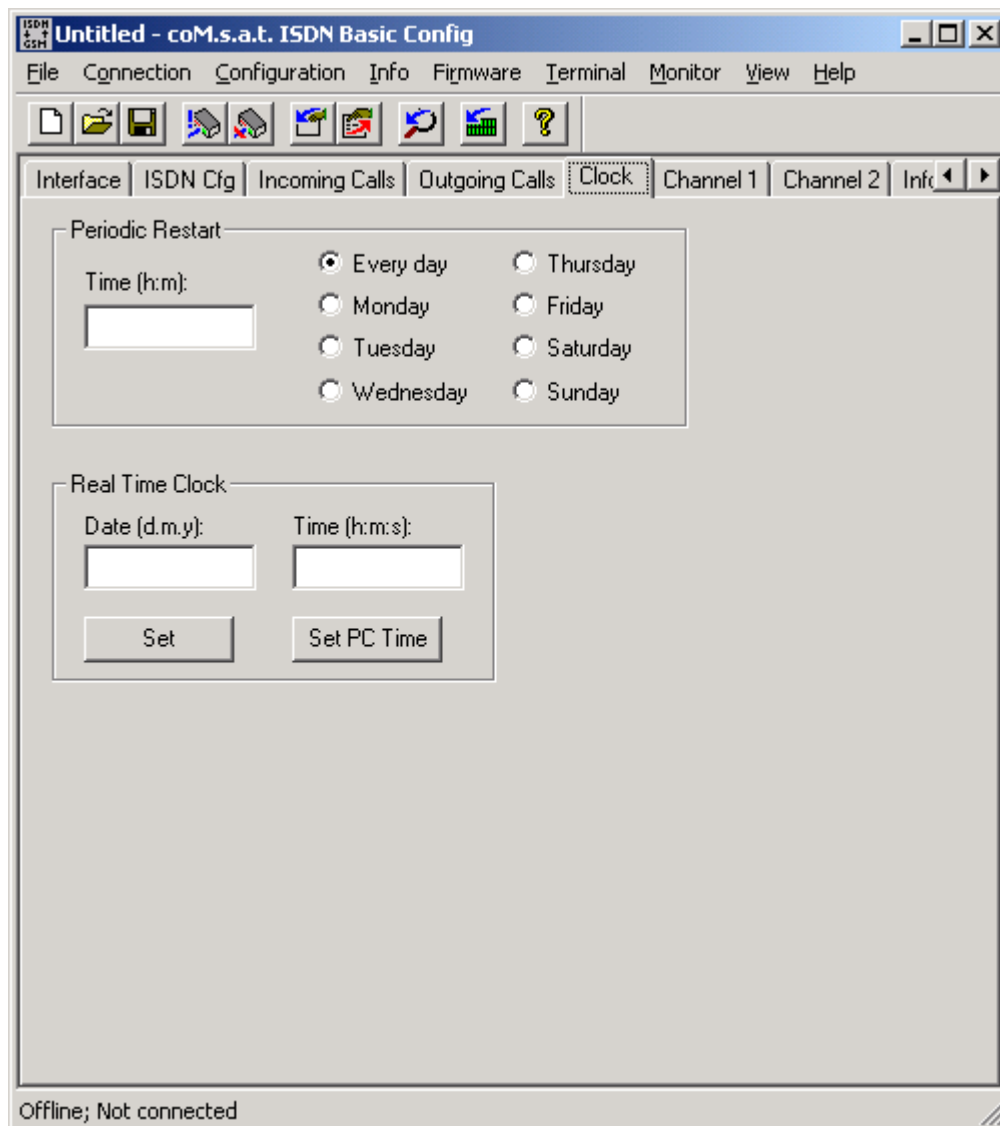

Figure 20: Clock

The **"Clock"** tab is used to set the device's real time clock. The respective time for the real time clock is then assigned to the entries in the trace memory to be able to follow the timing of the events entered there.

The current time is set by entering the date in **"dd.mm.yy"** format in the **"Date"** box and the time in **"hh:mm:ss"** format in the **"Time"** box. The time is updated by clicking on the **"Set"** button.

If the button **"Set PC Time"** is used, the current time is fetched from the PC's clock and transferred to the ISDN Basic. This function makes it a lot easier to set the current time if the PC time is correct.

With the menu "**Periodic Restart**" there is a possibility to restart the unit on a certain time and day. A periodical restart could have more stability in some difficult installations or locations.

3.3.14 Channel 1/2

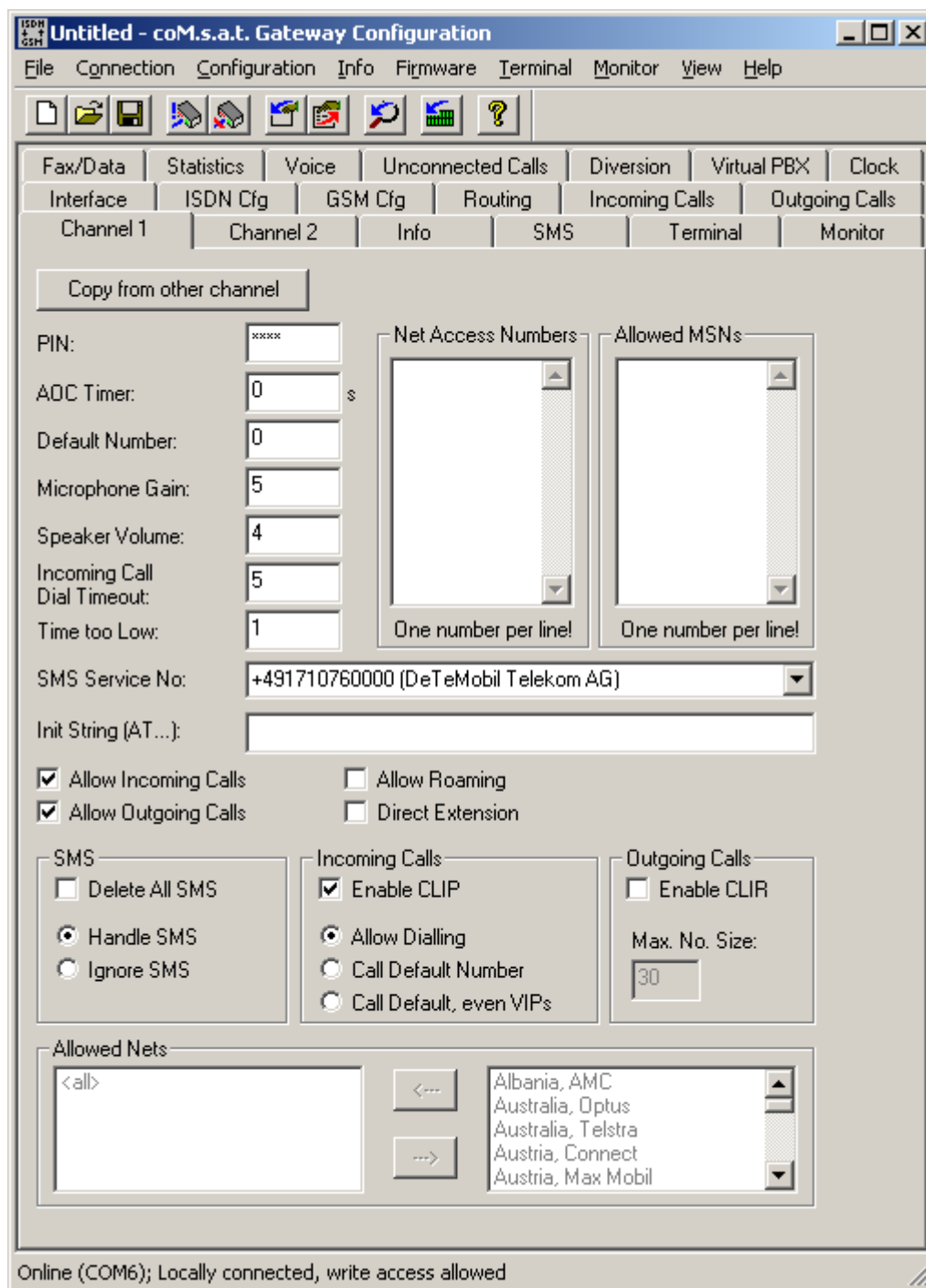

Figure 21: Channel 1/2

The card for the specific entries for channel 1 (same for channel 2) is used for entering the necessary details for the channel.

The SIM card "PIN" must be entered first. This entry is mandatory if entry of a PIN is prescribed for the SIM card used. In case the SIM cards used don't require such an

entry, the input box remains blank.

If the GSM network cannot provide real charge information, artificial charge information (phase) is produced by the "**AOC timer**". The AOC timer can be adjusted between 0 and 240 seconds.

The default number is the number of the extension that is called for incoming calls if "**Call Default Number**" has been selected. This number is also called if a caller does not dial anything.

The sound volume of the microphone and handset for the GSM channel can also be adjusted using this card if the preset level is insufficient. The preset values are 5 for "**Microphone Attenuation**" and 4 for "**Speaker Volume**". Both values can be altered between 0 - 7, whereby lower values represent lower volume and higher values higher volume.

The time during which a consecutive number can be dialled is also configurable. The time span is pre-set to 5 seconds. This should suffice for most applications, but can be changed in the "**Incoming Call Dial Timeout**" input box if necessary.

If prepaid SIM cards are used and their credit is set with the command "Set Prepaid Time" in menu "Info" (see 3.3.15), a threshold can be set in the field "**Time too Low**". If the credit falls below this threshold, the channel will not be used anymore. In addition, an SMS can be sent (see 3.3.3).

Furthermore, the number of the "**SMS service centre**" must be entered on this card, which is provided by the respective network provider whose SIM cards are used. The respective SMS centre can be selected from a list. This list is read in from the "sms.txt" text file. If one of the numbers given has changed or a new number is to be added or should the numbers of the network provider outside of the country in which the TA is installed no longer be visible, the corresponding amendments can be made by changing the text file. Of course it is also possible to enter any number instead of selecting one of the list entries.

An "**Init String**" is usually not needed. In some cases it may be useful to send an additional command to the GSM modules built into the device not given by the firmware of the device. Such an additional command can be entered in this field.

The network access numbers can be defined in a list box. This means that the dialling codes of the network providers that can be used for the calls are entered here. The numbers are entered as follows:

0170
0171

if e.g. only these two T-Mobile numbers are to be used.

Only one dialling code can be entered in each row.

Note: It is recommended to only make entries if restrictions are actually to be made. Otherwise it is advisable to leave this list box empty. In a further list box the numbers of those extensions that may access this GSM channel are set.

Furthermore, the incoming and outgoing calls are also configured here. You first define whether **"incoming and outgoing calls"** are allowed, then whether **"Roaming"** (booking into networks abroad) is allowed. To do this, the corresponding option box next to the relevant text is clicked on.

If the check box **"Delete All SMS"** is activated, any SMS received will be deleted after it has been processed. The option **"Handle SMS"** / **"Ignore SMS"** determines the reaction to incoming SMS. In areas, in which many SMS are dispatched for advertising purposes and with devices with a lot of traffic (where reading and deletion of SMS can be a nuisance) it is recommended not to react to SMS. If the option is activated, then SMS are not retrieved from the GSM module. In this case remote maintenance by SMS is no longer possible!

The option **"Direct Extension"** enables a special function of specific GSM networks, e.g. the spanish Telefonica GSM network. In this mode, all numbers called via GSM get a '#' and the calling MSN appended. This allows the called user to see which extension tries to call him. If a call from GSM comes in which has a '#' followed by an MSN in the calling party number information, the gateway directly calls this MSN.

You can also set whether the phone number of the incoming call (CLIP) is to be transferred to the extension (**"Enable CLIP"**). Also whether consecutive dialling is permitted or whether the incoming call is transferred to a preset extension, the number of which has been entered under **"Default Number"** (see above). Calling parties that are recognized as VIP are allowed to dial even if other callers are not if **"Call Default Number"** is selected. The option **"Call Default, even VIPs"** also disables dialling for these VIPs. If consecutive dialling has been allowed, it is possible to dial another extension during the first 5 seconds (or whatever time has been set) after a connection has been established. If nothing is dialled within this period, the default number is called.

If outgoing calls are allowed, you can select whether the caller number is to be transmitted or not (**"Enable CLIR"**). In addition, the maximum length of a number dialled to GSM can be configured in field **"Max. No. Size"**. This is important if the option **"Direct Extension"** is enabled. In this mode, the called number's length increases by the length of the calling MSN (see above). This increase of length may cause a number to exceed the limit of the GSM network, therefore the MSN is only appended if the resulting length is below or equal to the value configured here.

Note: If **"Allow Incoming Calls"** and **"Allow Outgoing Calls"** are deactivated, the channel is blocked for GSM calls.

If the **"Call Default Number"** option box is activated, the **"Default Number"** given above is dialled directly.

The allowed nets displayed at the bottom show which nets the channel can use (or if it can use all networks). These settings can only be modified if the password is known (see 3.3.21).

Once a channel is configured properly and the second channel needs almost the same configuration, use the button **"Copy from other channel"** in the second

channel to copy the settings of the first one, so that not all parameters must be configured twice.

3.3.15 Info

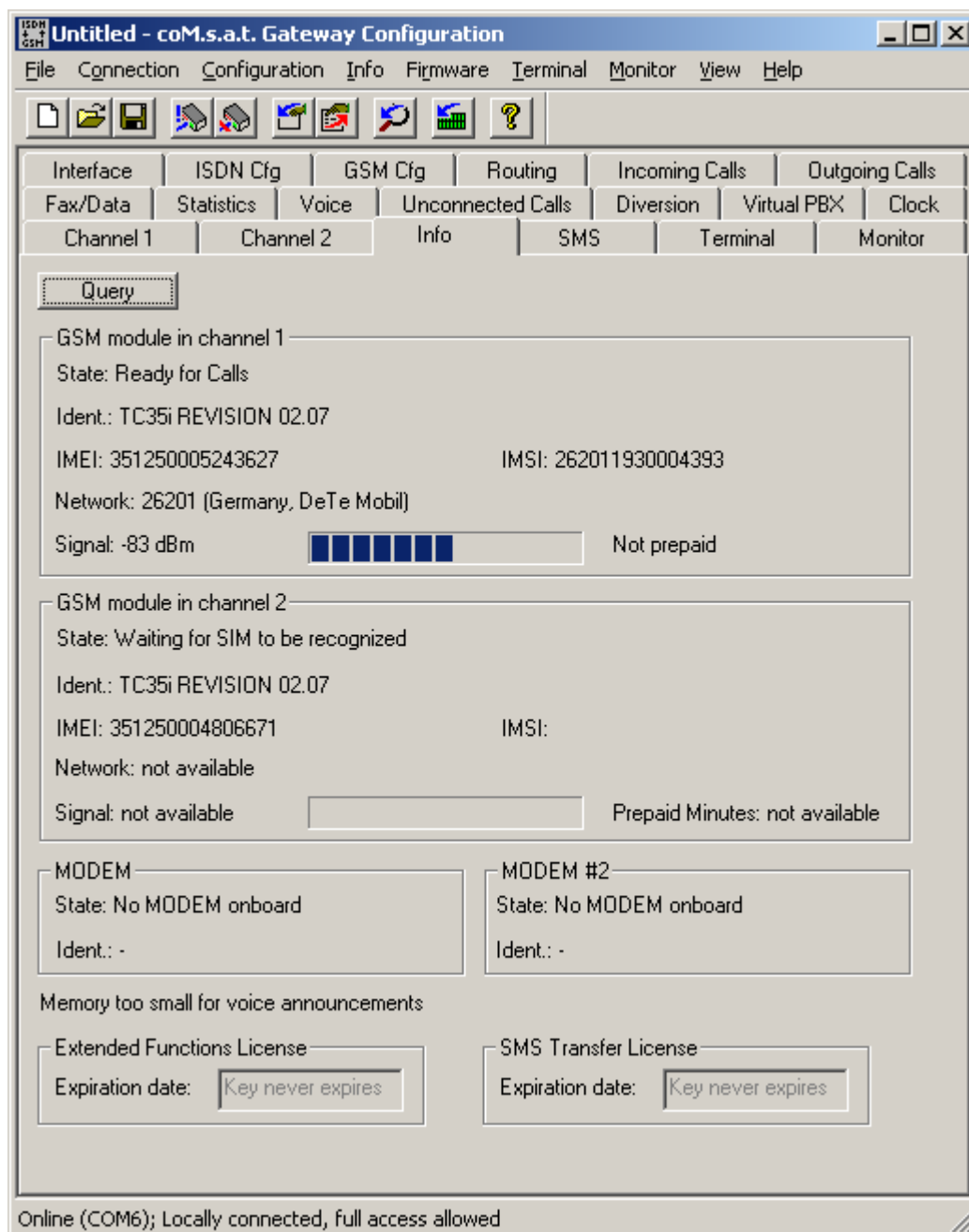

Figure 22: Module information

The state of the GSM modules which have been installed in the device are queried via the “Info” card file. The GSM modules’ current state, firmware revision, IMEI, as well as the IMSI of the attached SIM card and the current field strength of the antennas used at the installation site are reported. The currently available credit of prepaid SIM cards is also displayed. Since there is no modem in the ISDN Basic, both are always reported as “No MODEM onboard”.

The data is updated after selecting Query in the Info menu on the menu bar. Alternatively, you can use the following keyboard shortcuts:

<ALT> <I>
and
<Q>.

The state of the license for the extended functions of the ISDN Basic PRO is always queried if this page is opened. This license enables the use of the functions statistics, voice announcements, unconnected calls handling, call diversion and SMS server. This license is set the same way as in chapter 3.3.12.6 described for the virtual PBX, see there.

In addition, a status text below the modem information informs the user if the device is able to store voice announcements. It can show the message "Memory too small for voice announcements", "Memory size suitable for voice announcements" or "Extended functions disabled".

If licenses are stored in the device, their state is displayed at the bottom of the tab.

The above information can be read out and shown in text form by invoking "**In Terminal**" in menu "**Info**". Or the AT-command at\$i can be entered directly into the terminal window available in the "**Terminal**" tab. The module information is then presented in the terminal window as shown in the following figure:

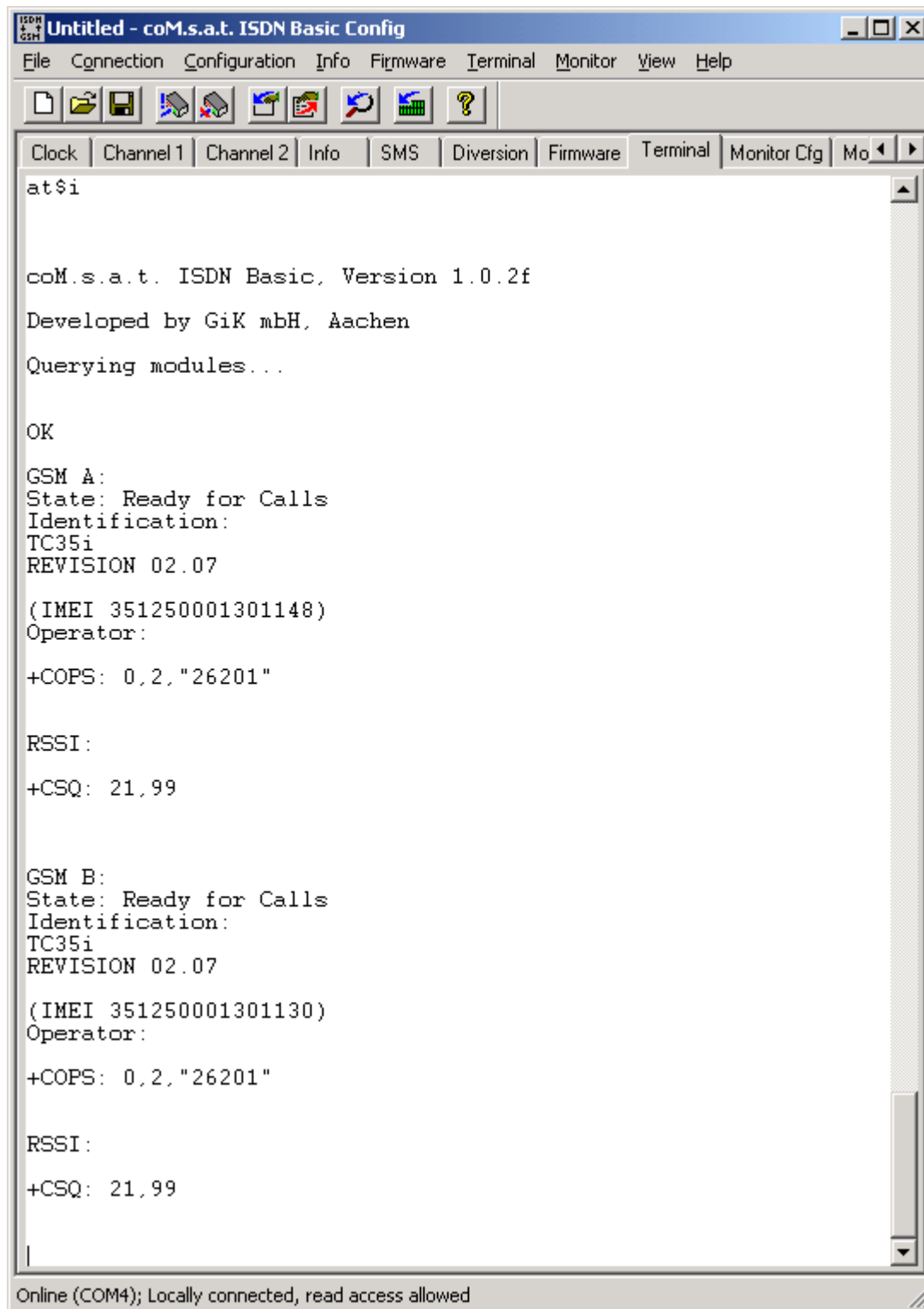

Figure 23: Module information in the terminal window

The menu "Info" also contains the command "Unlock SIM card". This function is needed if a SIM card is locked because of a wrong PIN. The following dialog opens:

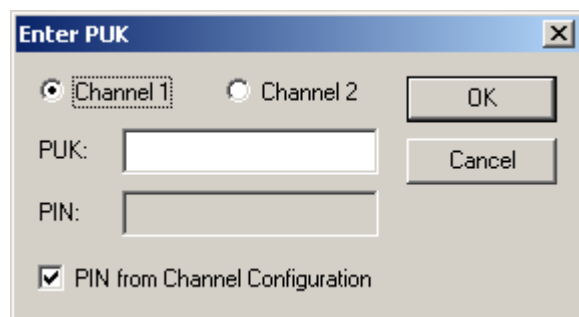

Figure 24: Unlock SIM card

The locked channel has to be selected and the PUK of the locked SIM card must be entered. The new PIN may be taken from the current configuration or entered manually. If "OK" is selected, the card gets unlocked and the result is reported. If it worked, the channel should log into the network.

Another command, "Set Prepaid Time", is used to set the credit of the channels. It uses the following dialog:

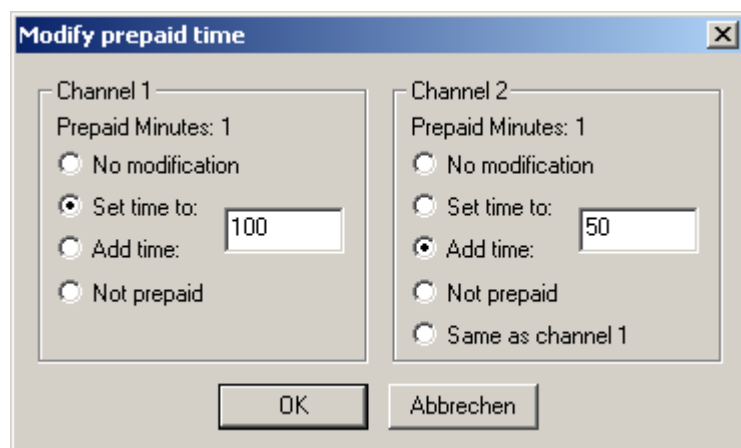

Figure 25: Set prepaid credit

Both channels allow the following choice:

- "No modification": No change to the credit of this channel
- "Set time to: ...": Sets the value entered in the edit field, i.e. the current value is overwritten
- "Add time: ...": Adds the value to the current credit
- "Not prepaid": Switches the prepaid function off

If both channels are modified identically, the desired modification can be entered for channel 1 and the option "Same as channel 1" can be selected for channel 2.

Note: After a power failure, it is possible that the prepaid time has an error of max. +/- 255 seconds.

3.3.16 SMS

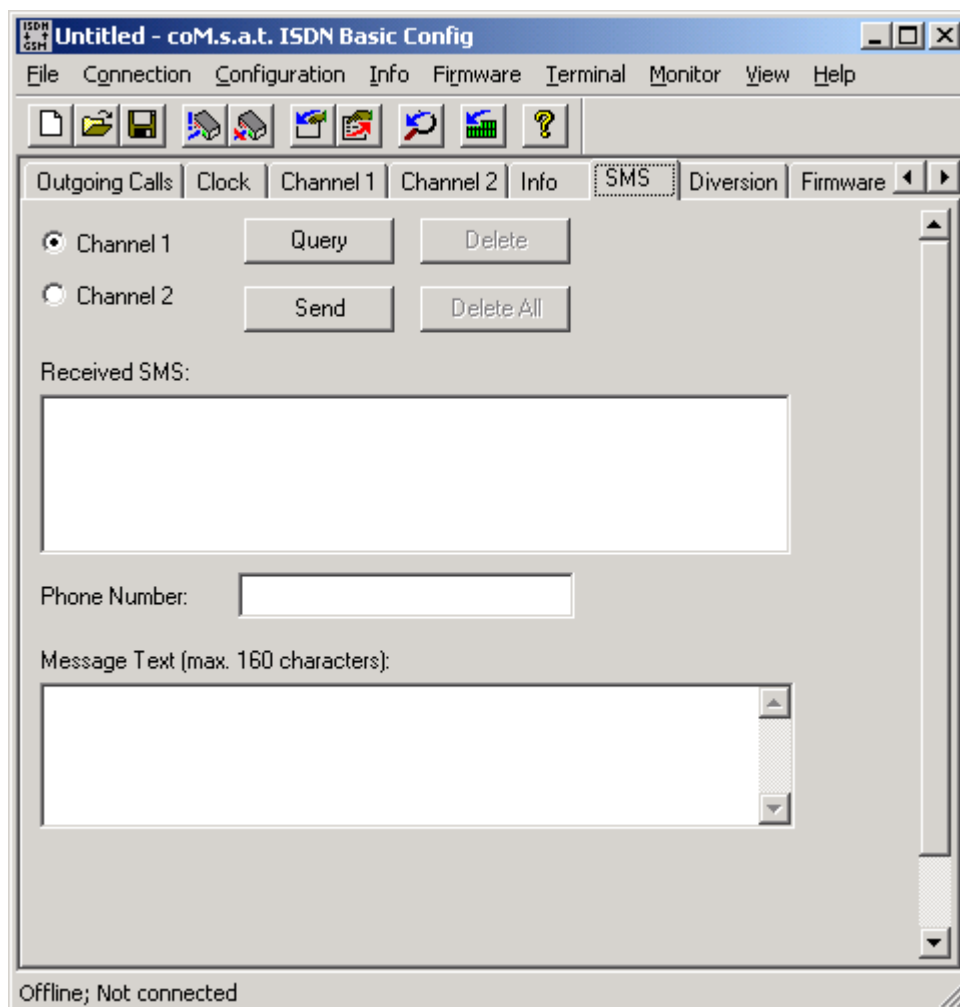

Figure 26: SMS

SMS messages can also be sent and received by the **coM.sat ISDN Basic**. This is achieved via the SMS card. First the channel via which the SMS messages are to be transmitted is defined in this card. The messages received are also administrated within this card. Two boxes are available for this; one for messages received and one for the message text. The telephone number of the SMS recipient is also entered in the card. SMS are transferred to and from the central office via the **“Query”** and **“Send”** buttons.

Note: SMS messages have a maximum length of 160 characters

Note: In order to be able to send SMS, the **“SMS Service Centre Number”** must be set in the **“Channel1/2”** tab.

The **“Delete”** and **“Delete All”** buttons are used to delete individual messages or all the messages in the **“Received SMS”** box.

3.3.16.1 *Receive SMS*

To receive SMS messages, first select the reception channel and then click on the "**Query**" button. SMS messages that in the meantime have been stored on the SIM card for this recipient are now called up and shown in the "**Received SMS**" list. However, only the date received and the phone number of the sender are shown in this box. The content of an SMS is displayed if an SMS is selected using the mouse pointer. The message text then appears in the box below, the phone number of the sender is displayed in the "**Phone Number**" box.

The following property must be noted for the receipt of SMS messages. As the received SMS messages are stored on the SIM card, the available memory is limited. However, to ensure access to the device via remote servicing, the oldest message is always deleted (if "**Ignore SMS**" is deactivated) to ensure that sufficient memory space is available for a new incoming message. The precise remote servicing sequence is described in the Remote Servicing chapter.

3.3.16.2 *Send SMS*

If an SMS message is to be sent, first select the channel and then enter the message text in the "**Message Text**" box, whereby the message must not contain more than 160 characters. To send the message, enter the number of the recipient in the "**Phone Number**" box and then press the "**Send**" button. The message is then sent.

3.3.17 Firmware

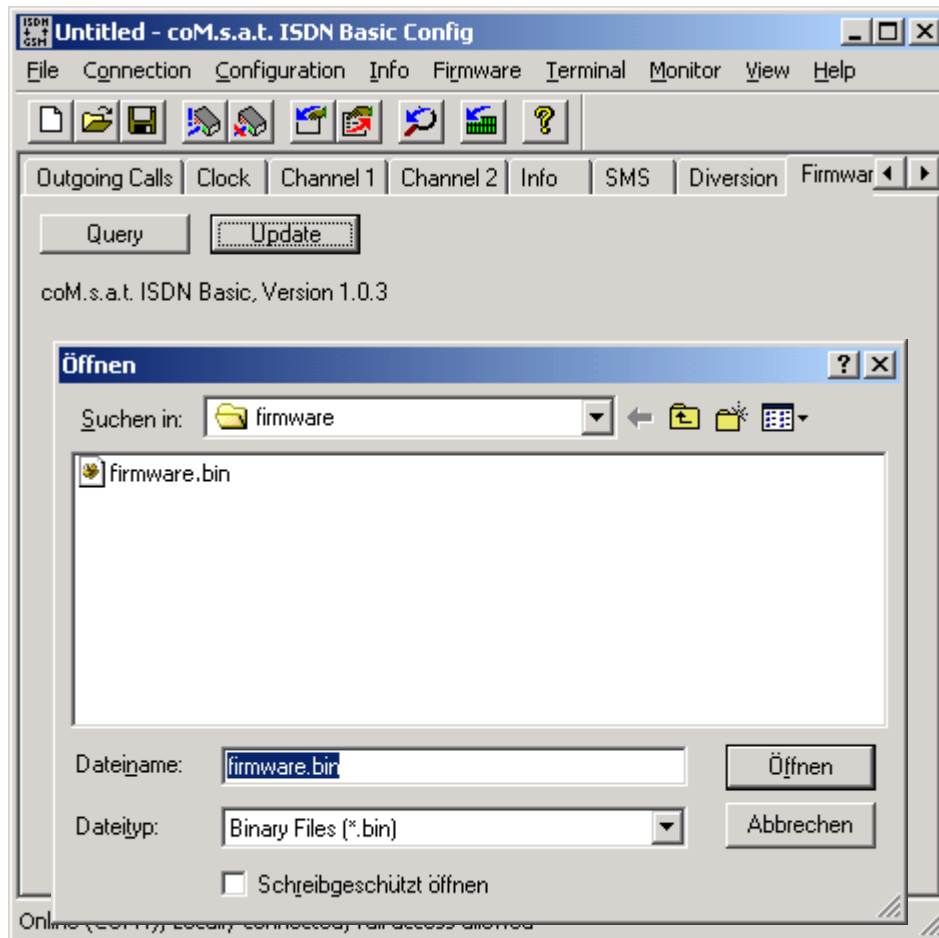

Figure 27: Firmware Update

The current version of the firmware used in **coM.sat ISDN Basic** is displayed in the “**Firmware**” card, after a query has been made via the “**Query**” button on the card or the “**Query**” entry in the “**Firmware**” menu of the menu bar. Alternatively, the keyboard shortcuts

<ALT><r>
and
<Q>

can be used.

A new version of the firmware can be transferred to the device via the data link with the aid of the **coMsat.exe** application. To do this, first select “**Firmware**” in the menu bar and “**Update**” from the menu. The usual Windows dialog for opening files is displayed. Select the file that is to be transferred to the **coM.sat ISDN Basic**. The transfer begins after clicking on the “**Open**” button.

Attention: The file to be loaded is "Firmware.bin", which is a binary file. To avoid malfunctions, only files approved by **coM.sat** should be loaded into the device.

In case of a power failure during reprogramming of the device or any other event that invalidates the program storage of the ISDN Basic, there is another tool that can program a new firmware even if the device is inoperable. The fload program located in the firmware directory is a command line based tool for programming the ISDN Basic. The fw_upd.bat batch file calls this program. Before using it, verify that it uses the correct COM port in the command line of fload. Then keep the reset button of the ISDN Basic pressed until the power LED is switched off for a moment. Release the reset button and run the fw_upd batch file. The firmware will be updated and after completion, the device must be reset again.

If the firmware shall be restarted, this can be done with the command "**Reset**" in the "**Firmware**" menu. This issues the command AT\$R to the device. This command can also be entered manually in the terminal. It requires a log in.

3.3.18 Terminal

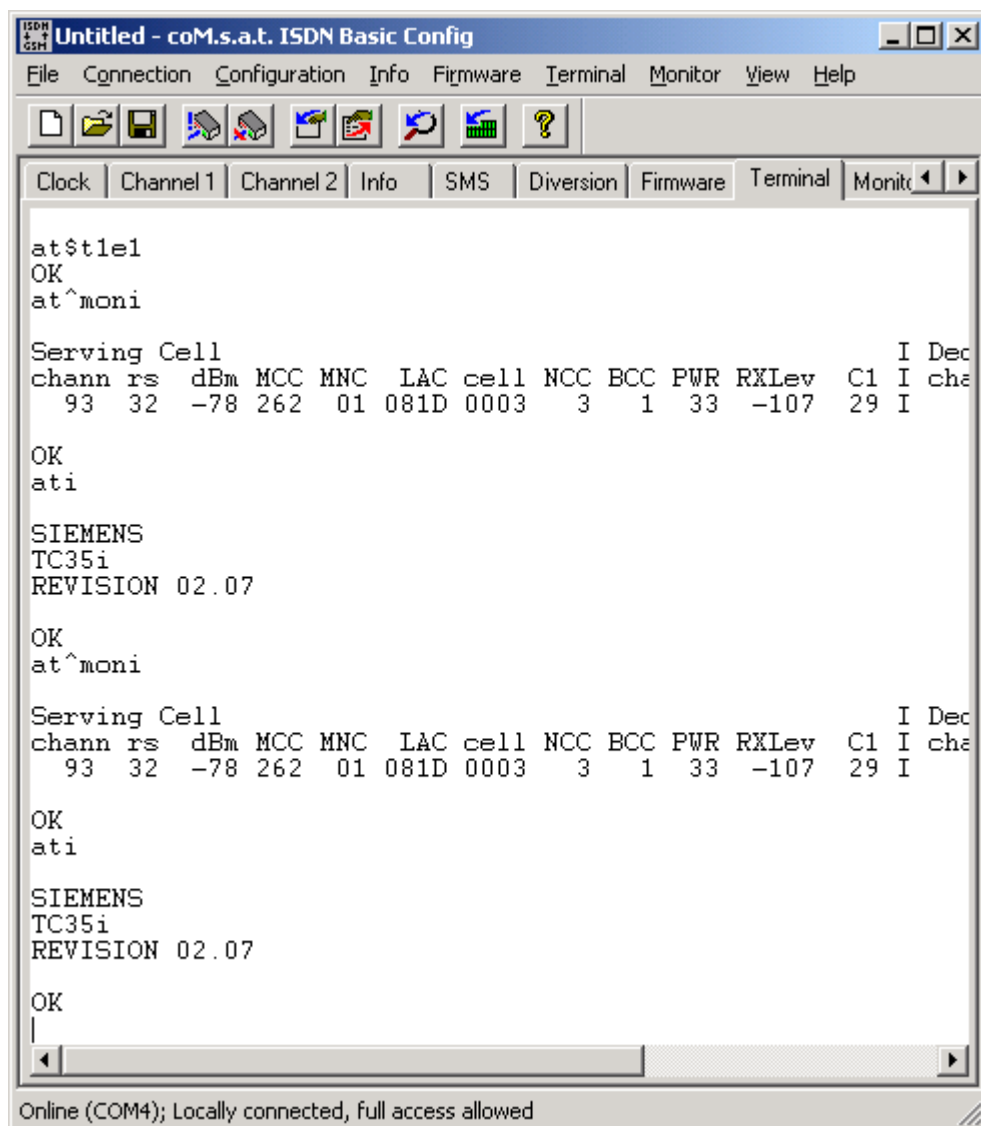

Figure 28: Terminal

The **“Terminal”** card acts like a terminal program. It can be used to track actions carried out by the **coM.sat ISDN Basic** in which a corresponding text is issued via the interface on the operations carried out by the TA. However, it is also possible to directly access the GSM module and to transfer commands to it. First the menu item **“Terminal”** is selected in the menu bar and then the entry **“Transparent Channel 1”** (or **“Transparent Channel 2”**) is selected in the menu that opens. The so-called AT commands, which are defined for the GSM module can then be used for the access. After completing the direct access to the GSM module, the transparent mode must be switched off again.

The protocol displayed in the terminal window can be used to analyse discrepancies. It can be saved for this purpose. However, it can also be deleted to record a protocol from a certain time onwards only. The protocol is saved or deleted by calling up the corresponding menu entry, "**Save**" or "**Clear**" in the "**Terminal**" menu on the menu bar.

3.3.19 Monitor

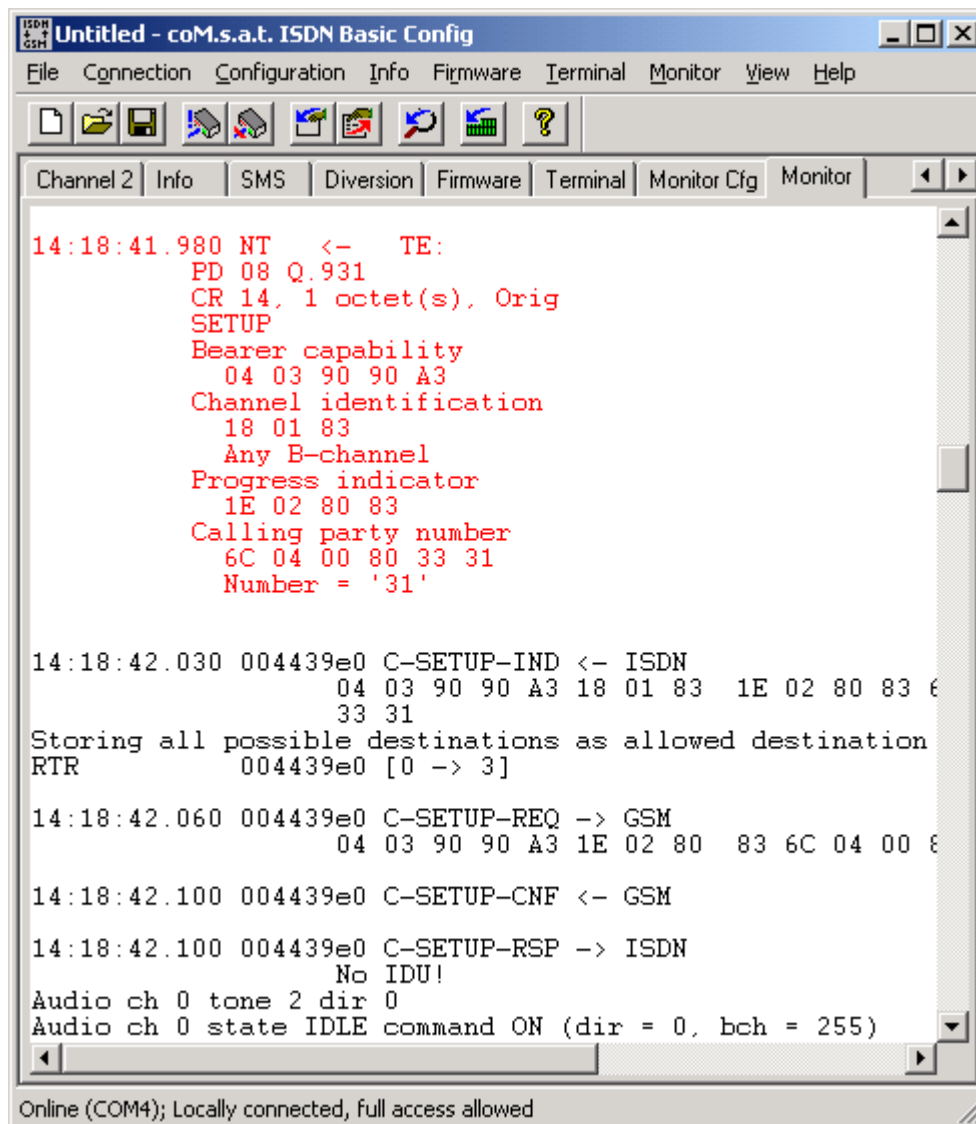

Figure 29: Trace recording

The activities on the S0 connection and between the **ISDN Basic** and the **GSM** modules are displayed on the “**Monitor**” tab, i.e. a “trace” of the D-channel protocol and the commands to the GSM modules as well as their responses are recorded. This data protocol is used both for in situ analysis when it is viewed in the monitor window as well as for analysis in another environment by saving it together with the configuration in a “*.cdc” file and opening this file with the **coMsat.exe** application on another computer. The ASCII save functionality is only available for using search and clipboard functions.

The information in the monitor protocol can be displayed in different colours for improved clarity. The colours for the various data and command paths are set in the **"Monitor Configuration"** card. Figure 29 shows an example of a "Trace".

Should certain installations induce the need for questions to the manufacturer, then the configuration, firmware version and module state should also be loaded besides the trace and stored together in a file and sent to the hotline of the manufacturer (Menu: File / Save as: <Expressive File Name>.cdc).

The **"Monitor"** entry menu provides options on what to do with the trace memory of the **coM.sat ISDN Basic**. It can be read out (Menu: **"Monitor"** / **"Load"**), the displayed trace can be stored in an ASCII file (Menu: **"Monitor"** / **"Save ASCII"**) or the displayed trace (not the trace memory in the ISDN Basic!) can be deleted (Menu: **"Monitor"** / **"Clear"**). The trace memory in the device occupies a defined memory area which cannot be increased. Thus, an exact storage duration cannot be given. It depends on the quantity of calls that are passed via the TA. The larger the number of calls the shorter the recording duration and vice versa. The recording duration can therefore range between a few minutes and approx. 1 hour. If such a trace is to be used for analysis, one should first be certain that the event actually occurred within the recording period. Otherwise, you should try to repeat the recording to "catch" the event. If an error can only be detected long after the event happened that caused the problem, it is necessary to load the trace periodically. This enables to "catch" the event even if it is hours ago. This function is described in chapter 3.3.1.

The look and the contents of the monitor can be modified. To do so, the following dialog can be opened by pressing the left mouse button in the monitor or by using the command in the context menu with the right mouse button:

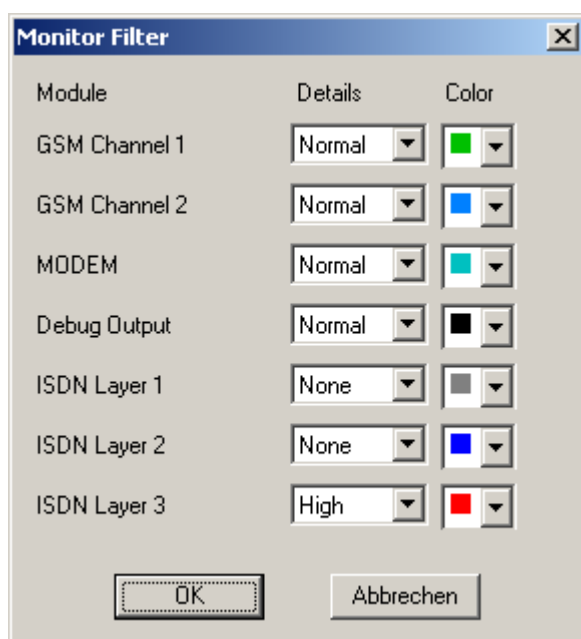

Figure 30: Monitor Configuration

In this way, the clarity of the presentation can be individually adjusted. The configuration can be used to hide information that is not important at present from the trace. However, it continues to be available for calling up and can be unhidden as needed.

Various details and colours can be selected for

GSM Channel 1

GSM Channel 2

MODEM (does not apply to ISDN Basic)

Debug Output

ISDN Layer 1

ISDN Layer 2

ISDN Layer 3

3.3.20 Additional information

The **"File"** menu lists the **"New"**, **"Open"**, **"Save"** and **"Save As"** menu items usually available under Windows. These are used by the standard Windows conventions and do not require any further explanation. As usual in Windows, the last 4 active configurations are listed in order (most recent first). The program can be quit by selecting the last menu entry **"Exit"**.

The menu item **"Monitor"** and the subsequent entry **"Load"** can be used to transfer current data from the **coM.sat ISDN Basic** for analysis. This data can be displayed via the **"Monitor"** tab and can be saved as an ASCII or a ".cdc" file. Further information on this is given in the **"Monitor"** and **"Monitor Configuration"** chapters.

The **"Toolbar"** can be selected via the **"View"** menu item and is positioned beneath the menu bar and by selecting the **"Status Bar"** the status bar below the main window is hidden or revealed. Furthermore, individual cards can also be called up via **"View"**.

The **"Help"** menu item is available to query the current version of the **coMsat.exe** application.

3.3.21 Vendor functions

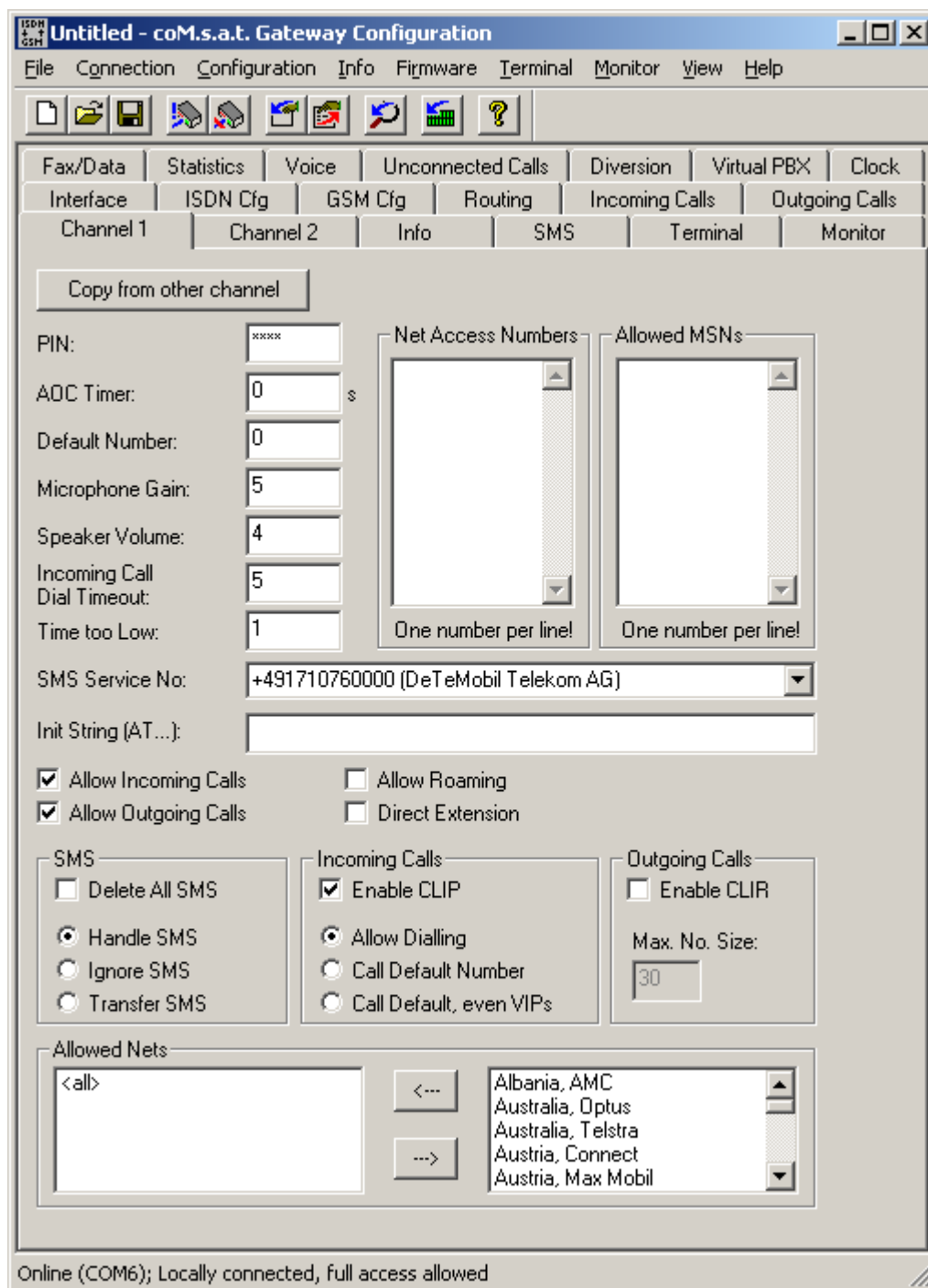

Figure 31: Vendor Functions in channel 1/2

Within the "Channel 1" and "Channel 2" tabs, the list boxes "Allowed Nets" is displayed above the lower edge if you have logged into the TA with full access rights (both passwords must be known). Network providers, into whose network the SIM cards may log into, can be designated by selecting from the right-hand list box and

clicking the "arrow left" button between the boxes. They can be removed from the selection list by marking them and then pressing the button with the arrow to the right.

4 Installation and operating information

Due to the diverse settings possible using the **coMsat.exe** configuration program there is a wide range of possible applications. As it is impossible to list and describe all these applications here, the following is limited to those currently considered the most important.

4.1 coM.sat ISDN Basic replaces network termination

To use the **coM.sat ISDN Basic** as network termination, the following connection schematic results. This can vary depending on the TC system used, although the principle arrangement is retained. The **coM.sat ISDN Basic** is installed as an exchange (NT) at the external S0 bus.

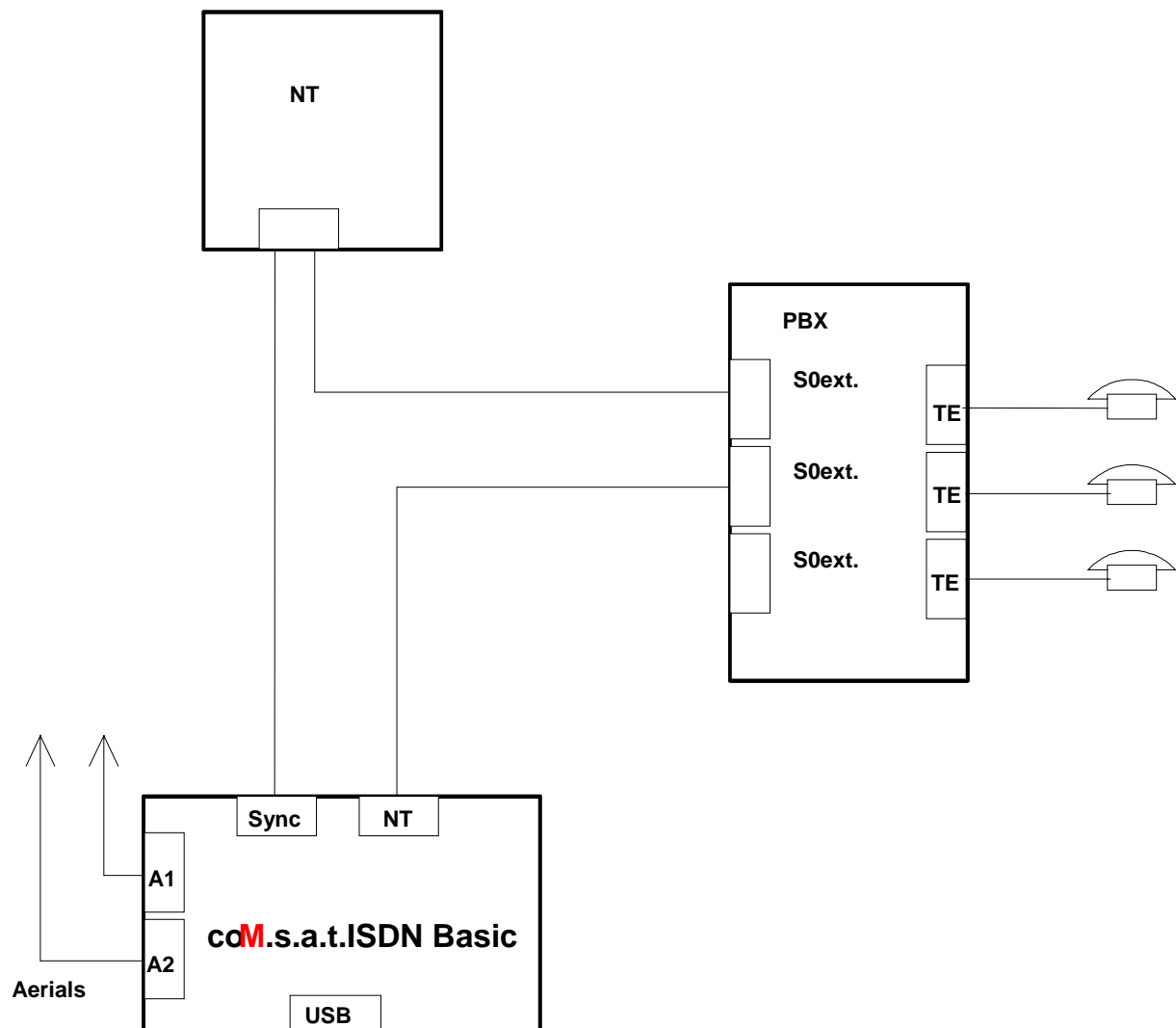

Figure 32: NT Installation

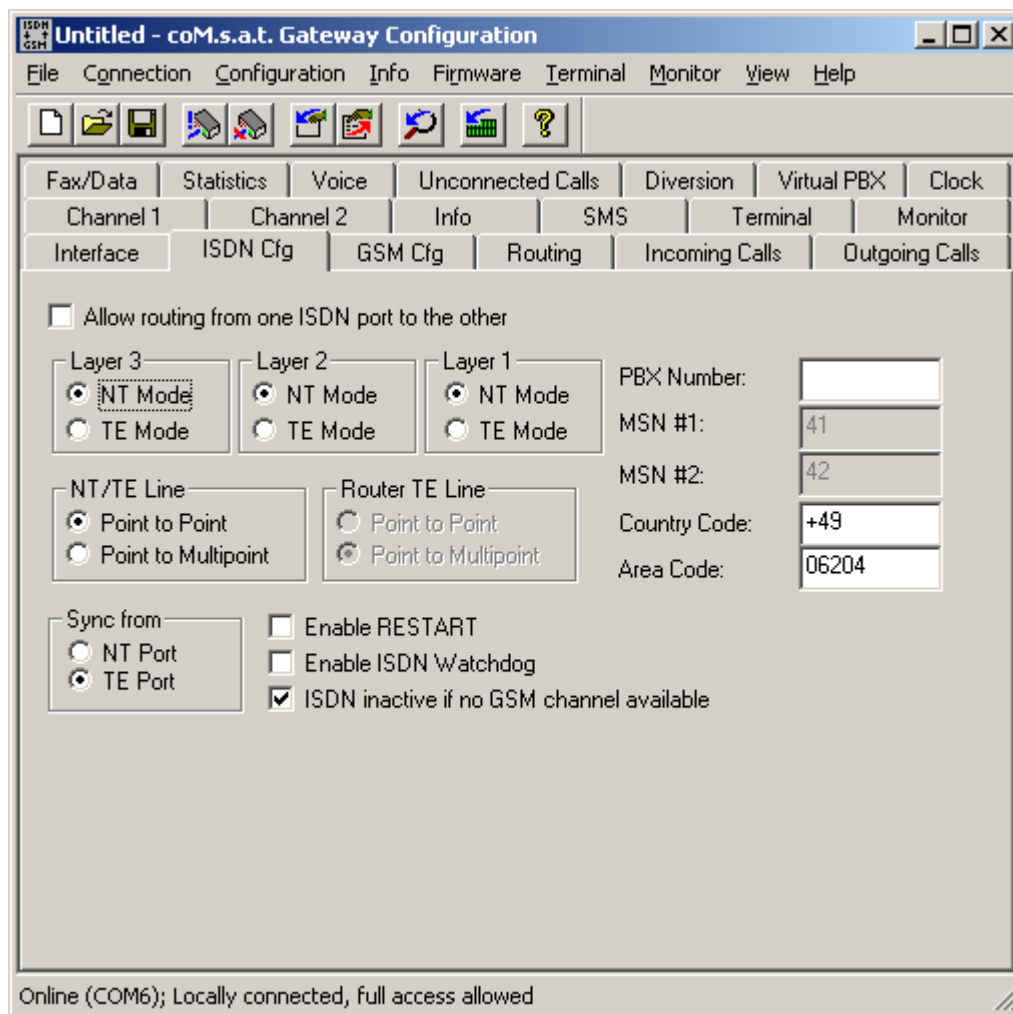

Figure 33: NT Configuration

This operating mode enables differences that may possibly occur between the clock pulses in the telephone network and in the **coM.sat ISDN Basic** to be avoided if the socket labelled **“TE/Sync”** is connected with the NTBA connection of the public network. If the connected PBX is able to use a clock derived from the first TE port on the second TE port connected to the **coM.sat ISDN Basic** and the optional add-on board for NT synchronization is installed, the TE/Sync port connection may be omitted if the “Sync from” configuration is set to “NT Port”. Note: Since the presence of the add-on board is not detected, the parameter field is always enabled in NT mode even if the add-on board is not employed.

Correct installation of the TA can be identified from the LEDs. If the GSM modules have booked into the respective network, the green LEDs light up permanently. If one of the modules logs off from the network during operation, the corresponding green LED of this channel begins to flash slowly. The yellow LEDs are always off when no call is being made. While a connection is being set up they flash and they are permanently lit during a connection.

Monitoring of the ISDN lines is switched on or off using the **“Enable ISDN Watchdog”** check box. If the box is checked, the monitoring is active on. A reset is

then performed after about 100 seconds if no ISDN connection could be established. If the watchdog is switched off, no reset occurs. In both cases the yellow LEDs indicate the state of the ISDN connection. If there is a problem with the physical connection, the yellow LED associated with channel 1 will be flashing. This indicates a problem with the connected device, e.g. a wrong cable. If the logical connection can not be established, the second channel's yellow LED will be flashing. This indicates most likely a configuration problem, e.g. a mismatch of point to point and point to multipoint configuration.

If the optional power supply add-on board is installed, then it is possible to connect telephones without own power supply directly to the NT port of the **coM.sat ISDN Basic**. The add-on board features a DC/DC voltage converter that generates the necessary voltage on the NT line. This is the same add-on board that also enables synchronization from NT port and direct connection of the NT and TE port during power failure, but it is available with or without power supply.

4.2 coM.sat ISDN Basic in TE mode

If a **coM.sat ISDN Basic** TA is to be operated in TE mode, the following connection schematic results. This can vary depending on the TC system used, although the principle arrangement is retained. In TE mode, the **coM.sat ISDN Basic** is installed as an internal extension (TE), i.e. it is operated at the internal S0 bus and behaves like a standard ISDN device. In this case, no synchronisation via the basic link is necessary.

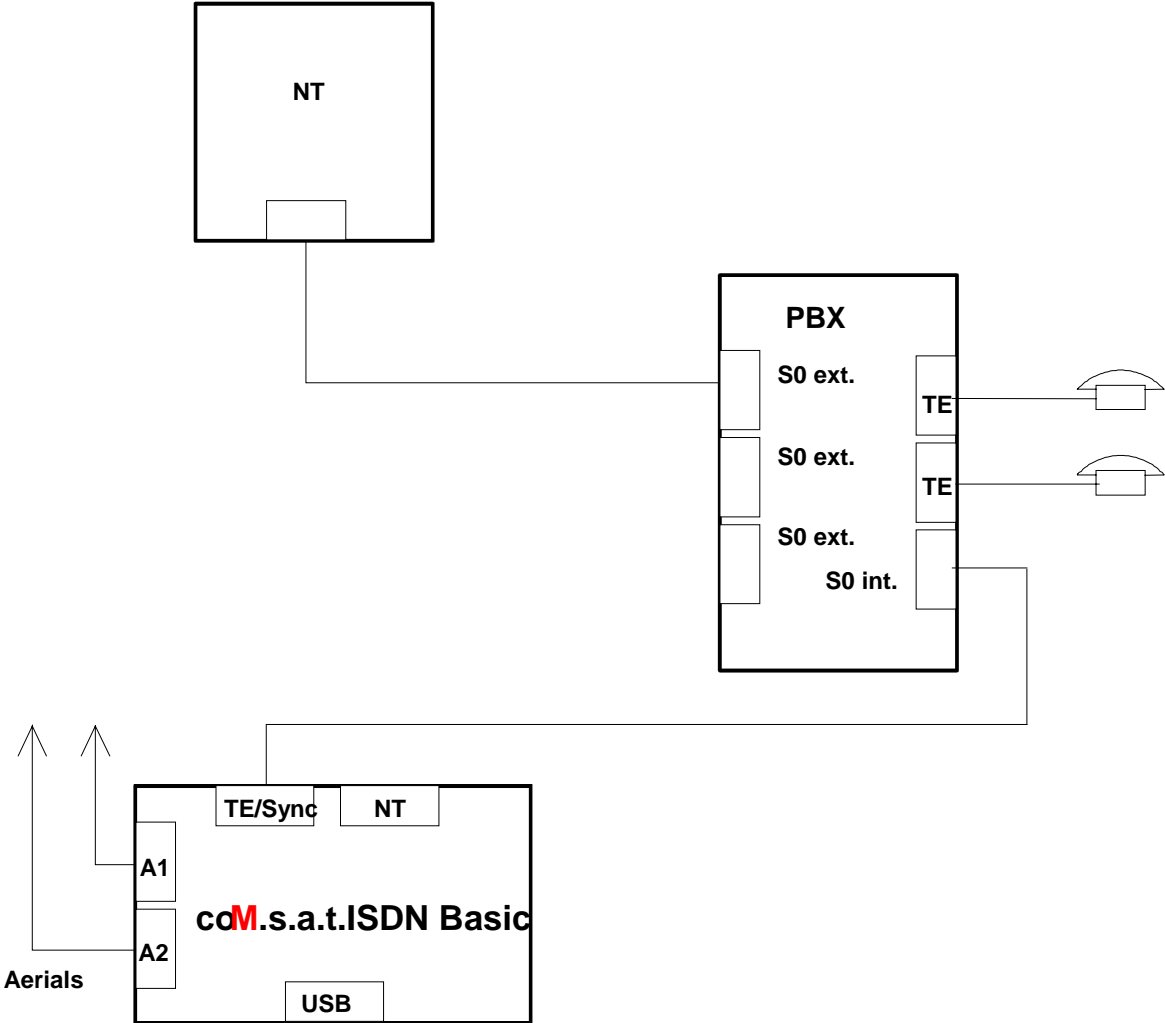

Figure 34: TE Installation

The following figure shows the settings for a possible and proven configuration. All layers have been set to TE mode and a point to multipoint link has been set. The synchronisation is carried out via the TE port.

In this mode the green LEDs function as in NT mode, i.e. if they are permanently lit, this shows that the GSM channels are logged in. If no call is being made then the yellow LEDs are off. While a connection is being set up, the yellow LEDs flash slowly. Once the connection has been made, this is indicated by the LEDs being permanently lit.

Furthermore, the connection to the TC system is also monitored and displayed. Correct function in TE mode is indicated by the red LED labelled "Sync" being permanently lit. On the other hand, the red LED (Sync) is off or flashes and the two yellow LEDs flash rapidly if there is a malfunction on the TE port.

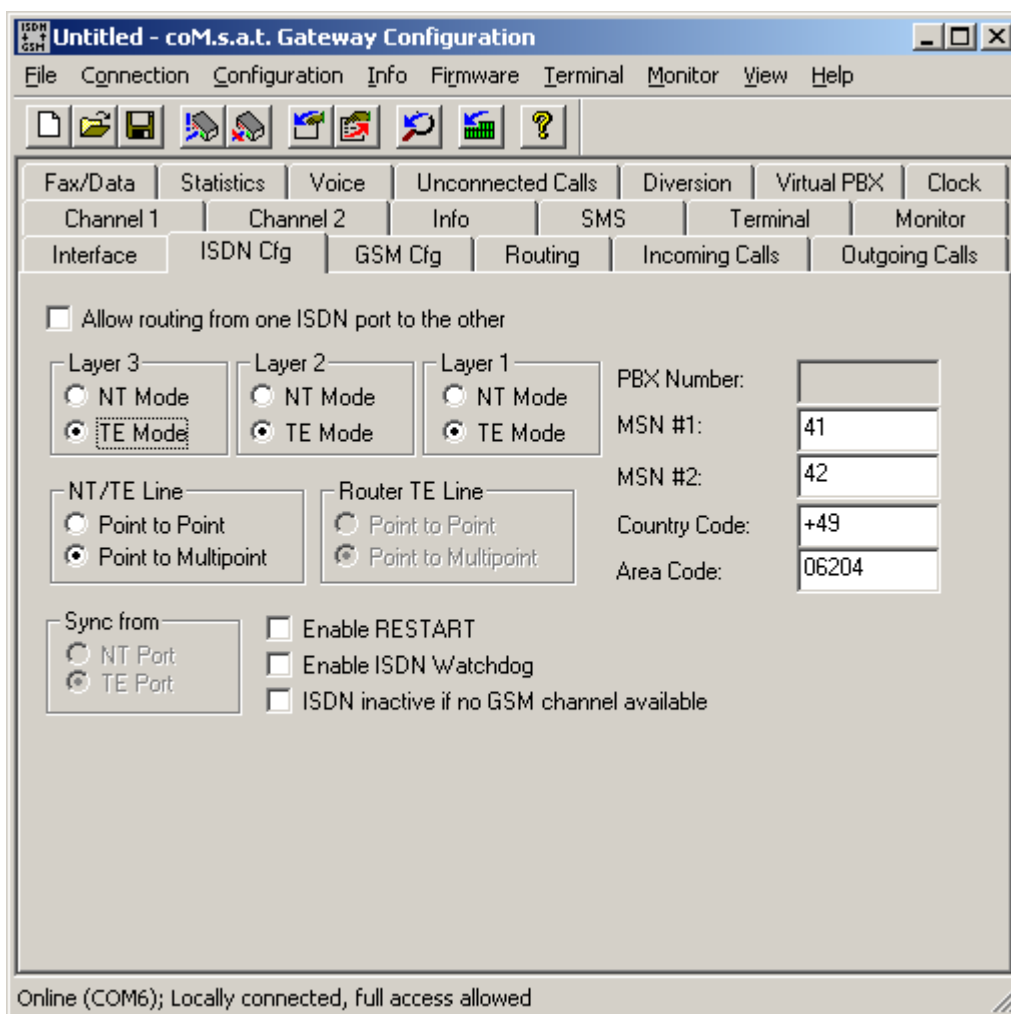

Figure 35: TE Configuration

4.3 coM.sat ISDN Basic in router mode

To use the coM.sat ISDN Basic as router, the following connection schematic results. This can vary depending on the TC system used, although the principle arrangement is retained. The coM.sat ISDN Basic is installed as an exchange (NT) at the external S0 bus and as TE at the ISDN network termination.

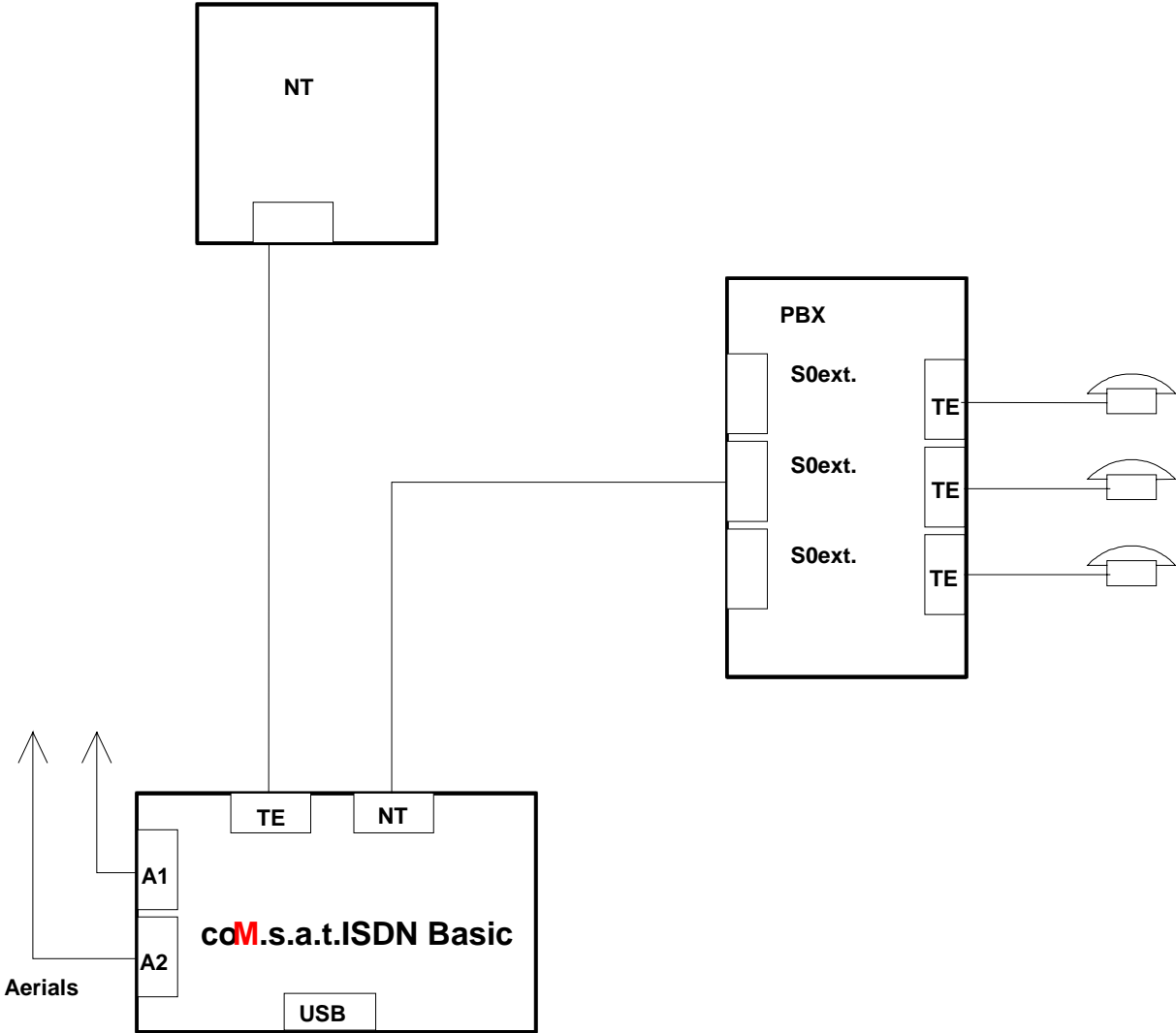

Figure 36: Router Installation

The following figure shows the settings for a possible configuration. Layer 3 must always be in NT mode and layer 2 and 1 are usually in NT mode, too. These settings apply to the NT port of the device, while the TE port is always configured in TE mode on all layers. The synchronisation is carried out via the TE port.

In this mode the green LEDs function as in NT mode, i.e. if they are permanently lit, this shows that the GSM channels are logged in. If no call is being made then the yellow LEDs are off. While a connection is being set up, the yellow LEDs flash slowly.

Once the connection has been made, this is indicated by the LEDs being permanently lit.

Furthermore, the connection to the network (TE port) is also monitored and displayed. Correct function in router mode is indicated by the red LED labelled “Sync“ being permanently lit. On the other hand, the red LED (Sync) is off or flashes to indicate a failure on the TE port and the two yellow LEDs flash rapidly if there is a malfunction on the NT port (as in NT mode).

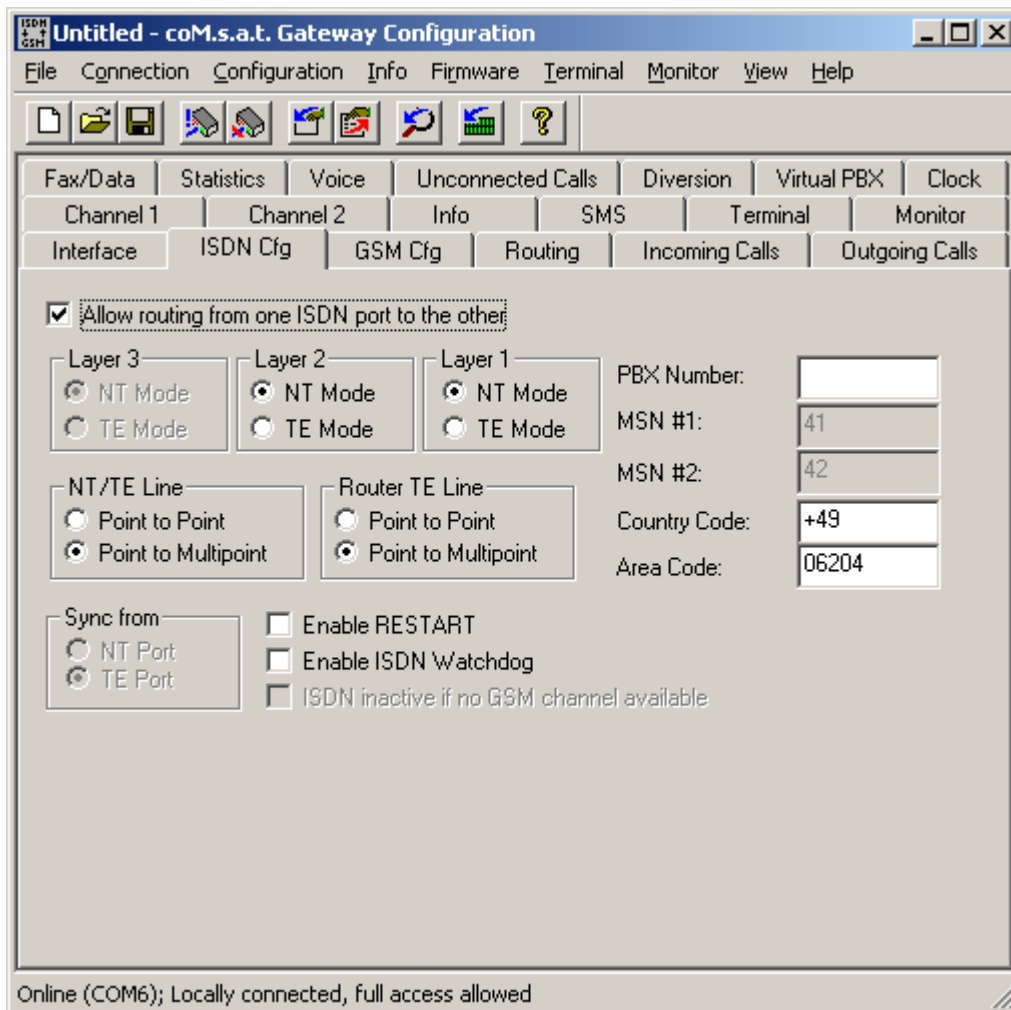

Figure 37: Router Configuration

If the optional relais add-on board is installed, the device automatically connects NT and TE port if no power is supplied. Thus it is still possible to make calls in case of power failure (e.g. by using emergency power supply from the ISDN network). If the power fails for more than a few seconds during active calls, they will be disconnected.

4.4 Transmit SMS

“Short messages“ can also be received and sent using the **coM.sat ISDN Basic** by connecting a PC on which the **coMsat.exe** application is installed to the **USB port** of the **coM.sat ISDN Basic**. After the link between the PC and the **coM.sat ISDN Basic** has been set up, the SMS card via which the SMSs are received and sent is called up.

Note: To do this, it is first necessary for the service centre numbers to be configured in the GSM channel card(s).

After selecting a channel, the SMs are simply received by clicking on the **“Query”** button, thereby reading the short messages from the SIM card. Any incoming messages are then shown in the upper box as a string in which the date, time and telephone numbers of the sender are displayed. The actual message text is displayed in the lower box when the message in the upper box is selected with the mouse. The text of a message can then be marked with the mouse and copied into the clipboard using the standard Windows keyboard shortcut <CTRL> <C> to make it available to another Windows application.

To send a short message, the text is entered in the lower box or transferred from the clipboard using the keyboard shortcut <CTRL> <V>. Then the transmission channel has to be selected and the number of the recipient entered. The short message is then transmitted by pressing the **“Send”** button. Supplementary information can also be found in Chapter 3.3.16.

4.5 Fax transmission via PC

A PC on which an application is installed and with which it is possible to exchange fax messages (e.g. WinFax Pro) is connected to the serial port of the **coM.sat ISDN Basic**. The fax messages are now exchanged from this PC via the **coM.sat ISDN Basic** to a fax machine and vice versa or even from a **coM.sat ISDN Basic** with connected PC to another **coM.sat ISDN Basic** with connected PC. To transmit fax messages, a SIM card must be used on which the fax message transmission option has been authorised.

4.5.1 Preparation of the PC for fax transmissions

Before installing the fax program on the PC to be used for the transmission of fax messages, the **coM.sat ISDN Basic** must first be installed as a modem. This required the **“ISDNPlus.inf“** file included in the software provided. To install the modem, call up Windows control panel and select **“Modems“**. The **“Modem Properties“** window then opens. Select the **“Add“** button and the **“Install New Modem“** window opens. Select the **“Select Modem (no automatic identification)“** option and then press **“Next“**. Another **“Install New Modem“** window now opens in which the **“Disc“** button is pressed. The **“Install from Disc“** window now appears at the foreground. Now click the **“Browse“** button in this window. The path to the directory in which the **“ISDNPlus.inf“** file is stored is then displayed in the following **“Open“** window and accepted with the OK button. The window now closes again and the **“OK“** button

pressed in the “Install from Disc” window that is now in the foreground.

The “Install New Modem” window is now in the foreground and the list box of modems includes the **coM.sat ISDN Basic**. After pressing the “Next” key the serial port (e.g. COM port (COM 1)) must be selected, via which the communications with the **coM.sat ISDN Basic** are to be made later. If “Next” is then clicked on in this window, the modem is installed. The end of the installation is confirmed by the message “The modem is now configured” and concluded by pressing the “Finish” button. The **coM.sat ISDN Basic** is now included in the Modem Properties window.

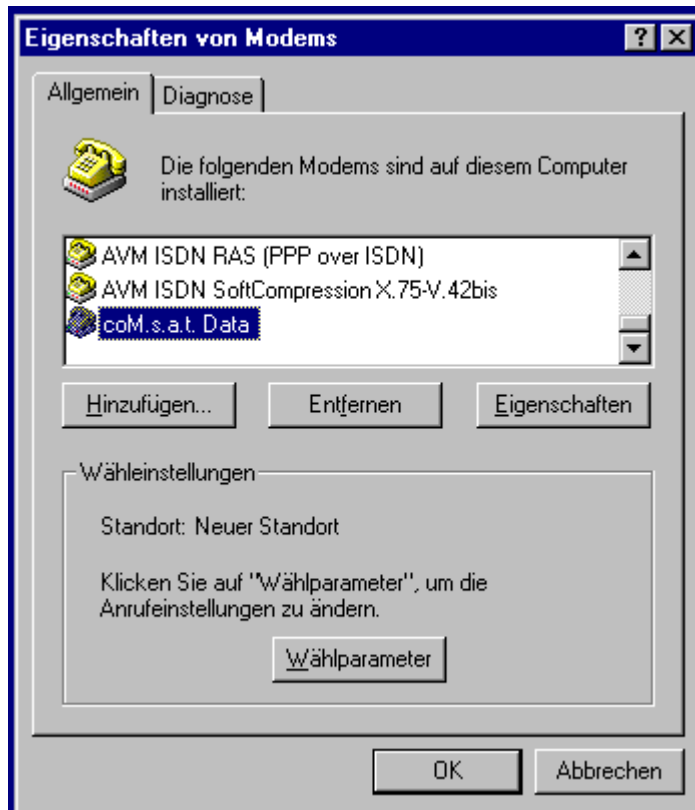

Figure 38: Install modem

Then the fax program can be installed by following the manufacturer’s instructions and documentation. When entering the modem to be used, select **coM.sat ISDN Basic**.

Note: Within the WinFax Pro application, the best results were achieved when transmitting fax messages to the **coM.sat ISDN Basic** when the ECM for receiving option and the High Speed Compression (2D) option were switched off and the maximum baud rate was set to 9600 Bd.

4.5.2 Send fax messages

If the installation has been carried out as described above and WinFax Pro has been set up, a fax message can now be sent directly from a word processing program, e.g.

Microsoft Word 97 or similar. After the file has been completed and is ready for printing, the printing procedure is initiated by selecting "Print" from the file menu and selecting WinFax as the printer in the "Printer" window that then opens. The printing process is now diverted via WinFax and sent as a fax. After initiating the printing process, the WinFax "Send Fax Wizard" is called up in which only the phone number of the recipient must be entered.

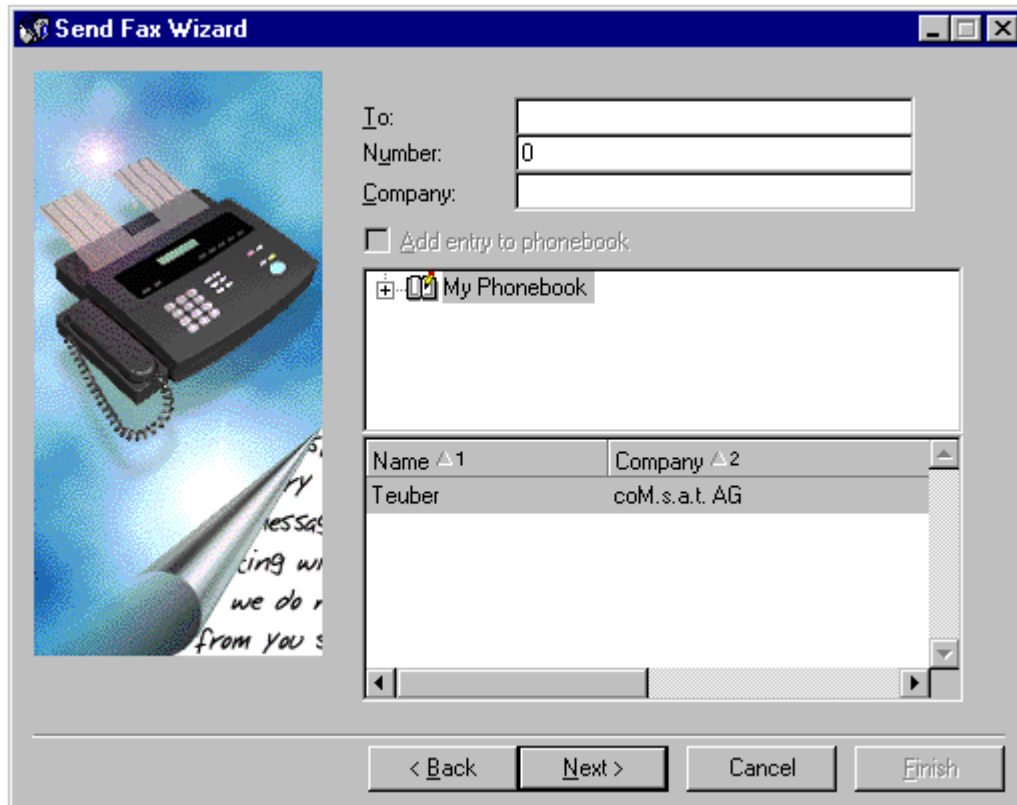

Figure 39: Send Fax Wizard

4.5.3 Receive fax message

Following standard installation, WinFax Pro remains ready to receive in the background. This is indicated by a small fax icon in the Windows symbol bar. If a fax message is now received, the data is automatically passed by **coM.sat ISDN Basic** to the PC on which WinFax is installed via the serial port.

4.6 Data transmission via PC

A PC with an installed application that can exchange data (e.g. Hyperterminal) is connected to the serial port of the **coM.sat ISDN Basic**. The data exchange is now carried out from this PC to another device capable of receiving data and vice versa. The other device can also be a **coM.sat ISDN Basic** with connected PC and a program for the exchange of data. It is also possible to connect into the Internet if an Internet browser (Netscape, Microsoft) is running on the PC connected to the **coM.sat ISDN Basic** and the connection with the Internet has been made via **GSM**.

To transfer data, a SIM card must be used on which the data exchange option has been authorised.

4.6.1 Preparing the PC for the transfer of data

The program required for the transfer of data must have been installed on the PC to be used for the transfer.

For example, Hyperterminal can be used for the transfer of data, or even the Internet browser. As these programs are usually already installed on the PC, no explanation is given for their installation here.

4.6.2 Sending and receiving data

After calling up the terminal program on the receiver and sender side, the receiver side is set in the operating mode for receiving calls while the receiver station is dialled by the sender side. After establishing the link, the data can be exchanged either by entering directly via the keyboard or by transferring files.

Internet access is achieved by dialling an Internet access by GSM and if necessary entering a personal access number.

4.7 Servicing / Remote servicing

The **coM.sat ISDN Basic** TA configuration can be checked in several ways, and the device firmware can be updated in a similar way. This type of servicing no longer requires that the TA be uninstalled and opened. The following methods are available.

- Servicing via the USB port of the TA
- Remote servicing per GSM

In both cases, a PC on which the **coMsat.exe** Windows application has been installed is required.

4.7.1 Servicing

If a PC is available at the installation site, a USB link is established between the **coM.sat ISDN Basic** and the PC and after calling up the **coMsat.exe** application, the link to the TA can be established by logging in for making authorised changes to the configuration. The next steps are then reading the configuration or updating the firmware.

4.7.2 Remote servicing

The other possibility is to set up a link between the service PC and the TA via a GSM network. To do this, a **coM.sat ISDN Basic**, a **coM.sat ISDN Plus** or a GSM modem must be connected to the service PC itself. Furthermore, the numbers of the TAs to be serviced must also be known at this site. The link is now made as follows:

The service PC sends the **coM.sat ISDN Basic** a short message (SMS) containing the callback number. The device then sets up a data link.

After the SMS has been sent, the service PC is switched over to the terminal window and the channel via which the message was transmitted was switched to transparent mode. When the return call is received, a “**RING**” can be identified in the terminal window. The “**RING**” is now manually answered with the “**ATA**” command. The link to the remote device is now displayed by the “**CONNECT**” message. After setting up the link, the service PC can be used to work with the remote device, as if it were connected directly to the PC. For example, the configuration data can be interrogated, altered and sent back. In this process, a SIM card that permits the transfer of data must be inserted in the device used in the service centre. The phone numbers and, if necessary, the passwords of the remote device must be known.

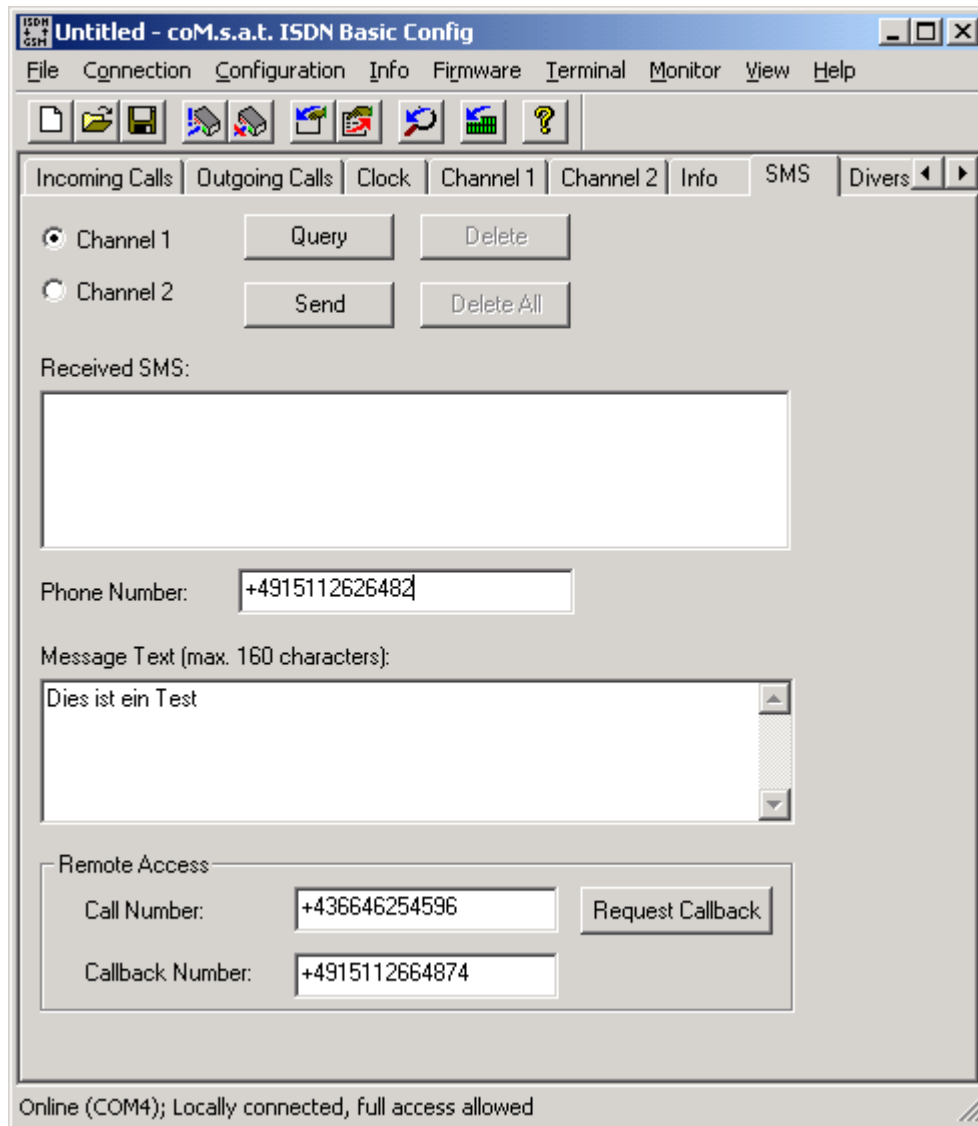

Figure 40: Remote Servicing

These two phone numbers are entered in the "SMS" file card within the **coMsat.exe** application. To do this, it is necessary to log in with full access rights. The phone numbers are then entered in the "Call Number" and "Callback Number" boxes. The "Call Number" gives the GSM phone number of the station to be called and serviced. The "Callback Number" is the number of one of the SIM card in the channel of the service station that transmits the SMS. Furthermore, the "SMS Service Number" must be entered for the channel on the service station side in the "Channel 1(2)" tab.

By selecting the "Request Callback" button, the remote servicing process is initiated. In the first step, an SMS is sent to the device to be serviced. This then sets up a data link to the service centre.

As soon as the reply:

RING

arrives from the called device, input

ata

from the keyboard to pick up the link.

The device called answers after a short time with

CONNECT.

The link to the device to be serviced has now been established. The link is identified by the relevant information being displayed on the status bar. It is then possible to log in into the remote device to be serviced via the currently running **coMsat.exe** application. All other operations on this device are carried out as already described.

It is important that the link is set up from the remote device to avoid installing SIM cards capable of incoming data calls have to be installed in the remote device only for update and service purposes.

If the link is to be disconnected, the string

+++

OK

ath

is entered at the PC. The "+++" calls up the command mode of the device again and "ath" ends the link.

If an update of the firmware is made a reset is carried out on the device called after receiving and accepting the data, to be able to carry on working with the new data afterwards.

Note: If the SMS is sent manually, a MODEM attached to the fixed telephone network or a GSM MODEM can also be used for remote servicing.

4.7.3 Read out/Transmit configuration

After logging in into a **coM.sat ISDN Basic**, the configuration is read out by selecting "**Configuration**" in the menu bar and "**Query**" in the menu that opens. **coM.sat ISDN Basic** then interrogates the configuration and displays it via the **coMsat.exe** application. The **coMsat.exe** application can now be used, if required, to make the necessary changes. Then the configuration data are transferred back into the **coM.sat ISDN Basic** by again selecting "**Configuration**" in the menu bar and then "**Update**" in the menu that opens.

4.7.4 Software update

After logging in into a **coM.sat ISDN Basic** the current version of the firmware is automatically read or can be read out by selecting "**Firmware**" in the menu bar followed by "**Query**" in the menu that opens. The **coM.sat ISDN Basic** then interrogates the status of the firmware and displays it in the "**Firmware**" card of the **coMsat.exe** application.

The firmware is updated by selecting "**Firmware**" in the menu bar followed by "**Update**" in the menu. The familiar Windows dialog then opens with actions such as "**Open File**". The "**Firmware.bin**" file to be transferred is selected from the list box and after pressing the Open button is transferred to the **coM.sat ISDN Basic** to which it is linked.

5 Questions and answers

Question: **coM.sat ISDN Basic** is being configured with the aid of a PC. But access to the **device** is apparently not possible.

Answer: You have forgotten to login.

The wrong port (COMx) has been selected in the Interface card in the **coMsat.exe** application.

Question: The **coM.sat ISDN Basic** is being configured with the aid of a PC but without a TC system having been connected. All the LEDs suddenly start to flash and access to the device is no longer possible.

Answer: In this operating mode, a “reset“ is carried out at intervals of around 100s. You have to login again after a “reset“ and after the device has been started up again.

Question: The **coM.sat ISDN Basic** is supposed to be configured for NT mode, but it won't start after downloading the configuration data.

Answer: All three optional layers, Layer 1 - 3, have not been selected for NT mode.

Question: The **coM.sat ISDN Basic** is supposed to be configured for TE mode, but it won't start after downloading the configuration data.

Answer: All three optional layers, Layer 1 - 3, have not been selected for TE mode.

Question: The monitor card is selected during operation but nothing changes within the card or it remains empty.

Answer: The trace memory in the device is only read out on request. To do this, select **Monitor** in the menu bar and then select **Load**. The display in the card is deleted by selecting **Clear** from the menu. Attention: The content of the memory is not continuously transferred to the PC after the first request with **Load!** A new enquiry must be made for each update.

Question: The SIM card PIN numbers have been entered via the **coMsat.exe** application and entered in the **coM.sat ISDN Basic**. However, the device fails to book in. The green LEDs, which indicate booking in by being continuously lit, continue to flash.

Answer 1: SIM cards must be used that can work with an operating voltage of 3V. All new SIM cards are usually suitable. If older SIM cards are used, which are only designed for 5V operation, it is possible that the device cannot book into the network despite the correct PIN number being entered. Ask your network provider what type of SIM cards they issue.

Answer 2: The antennas have not yet been connected.

Question: Are the antenna affected if they are set up too close?

Answer: Yes, if two antennas are used, they must be set up at least 1 m apart to keep the effect they have on each other to a minimum.

Question: Why can't a GSM caller dial in even though he should be able to?

Answer: There are TC systems that forward all calls without called party number to a specific extension. In the normal configuration, the **coM.sat ISDN Basic** reports an incoming call to the PBX without called party number to check, if it is able to handle a call. If the PBX already starts alerting an extension on that message, the GSM user can not dial anymore. Change the setting of the “Dialling Mode” on page “Incoming Calls” to “En-bloc”. Then no message is sent to the PBX until the complete called party number is available.

6 Technical data

Power supply unit	12-14 V DC, max 1 A
Current consumption	max 380 mA average quiet current max 900mA operating current (2 channels active)
GSM 900/1800 Standard	GSM Phase II Voice SMS (Receive / Send in text mode)
Transmitter power	max. 2 Watt per channel (GSM 900) max. 1 Watt per channel (GSM1800)
SIM Card	3V SIM card
Interfaces	USB-B 1.1 interface connector for programming and monitor operation, sending and receiving SMS messages S ₀ interface (NT or TE, P-P or PMP settable, EDSS-1 protocol, impedance 100 Ω) as RJ 45 socket
Antenna	50 Ω impedance on SMA socket
Dimensions (B x D x H)	170 x 225 x 50 mm
Weight	approx. 700 gr
Temperature range	0 °C to 40° C

6.1 Connector assignments

Electricity supply:

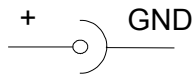

Central carrier wire:

+10..12V

External conductor:

GND

NT Connection:

NT	PIN	EIA	Description
	1	NC	No Connection
	2	NC	No Connection
	3	Rx+	Receive Data +
	4	Tx+	Transmit Data +
	5	Tx-	Transmit Data -
	6	Rx-	Receive Data -
	7	NC	No Connection
	8	NC	No Connection

TE/SYNC Connection:

Sync	PIN	EIA	Description
	1	NC	No Connection
	2	NC	No Connection
	3	Tx+	Transmit Data +
	4	Rx+	Receive Data +
	5	Rx-	Receive Data -
	6	Tx-	Transmit Data -
	7	NC	No Connection
	8	NC	No Connection

Appendix 1: LED Function

The **coM.sat ISDN Basic** features altogether 6 LED's in different colours, intended to display the different operating conditions. An imprint on the housing allows for the identification of the LEDs' function.

Name	LED colour	Status	Meaning
Power	green	on	ready, on
		off	off
Sync	red	on (TE) or flashing (NT)	TE Mode: ISDN connection up NT Mode: Synchronisation present
		off	TE-mode: line fault NT-mode: device is operated w/o synchronisation, or line fault
Network	green	off	Booting
		flashing quickly	GSM channel not ready (initializing, no SIM card, incorrect PIN, ...)
		flashing slowly	GSM channel presently logging into network
		on	GSM channel currently logged into network
Active	yellow	off	no connection via channel
		Flashing quickly	no ISDN link (one LED for layer 1 and one for layer 2)
		Flashing slowly	connection is being established or transparent access by PC over USB
		on	connection is established

Appendix 2: Terminal commands

When using the terminal window of the **coMsat.exe** application it is possible to both directly access the GSM modules as well as the device itself using special commands. The commands for the GSM modules are not described here as they are described in the GSM module manufacturer's documentation. The special commands for the **coM.sat ISDN Basic** are described in the following:

Command	Meaning
at\$ =“<password>“<enter>	Login to the TA if the password is correct. If the <password> =<configuration password> <vendor password>, full access to the TA's functions is possible.
at\$i<enter>	Issues the identification and status as a reply
at\$t1<enter>	Transparently switches to Channel 1 if the TA is in the “Ready“ state. It is necessary to login first!
at\$t2<enter>	Transparently switches to Channel 2 if the TA is in the “Ready“ state. It is necessary to login first!
at\$x1<enter>	Transparently switches to Channel 1 in any state (caution!!). It is necessary to login first!
at\$x2<enter>	Transparently switches to Channel 2 in any state (caution!!). It is necessary to login first!
at\$&f<enter>	Reinstates the factory settings. It is necessary to login first!
at\$r<enter>	Reset the device. It is necessary to login first!
ati<enter>	Issues brief information
ate0<enter>	Switches the echo mode off.
ate1<enter>	Switches the echo mode on.
at\$dv <enter>	Deletes all stored voice announcements. It is necessary to login first!
at\$time? <enter>	Answers the current time of the device
at&d0 <enter>	Ignores the state of the DTR line, i.e. the PC can disconnect the local connection without automatic logout; transparent connections are also not disconnected automatically (attention: can only be disconnected by restarting the device!)
at&d2 <enter>	Watches the state of the DTR line again (see above)
at\$smslist=<channel> <enter>	Answers a list of stored SMS on <i>channel</i> (1 or 2).
at\$smssend=<channel>,” <number>”,<text>” <enter>	Sends an SMS with <i>text</i> to <i>number</i> via <i>channel</i> (1 or 2).
at\$smsdelete=<channel>,” <index>” <enter>	Deletes the SMS with <i>index</i> of <i>channel</i> (1 or 2). The index is the first number in the output of a received SMS
at\$cdrg <enter>	Returns the statistics (Call Data Records)
at\$cdrd <enter>	Deletes the statistics
at^moni<enter>	Replies with information about the cell, field strength, network provider, etc. (Transparent connection to GSM module required)

at^moni=1<enter>	Replies cyclically every second with information about the cell, field strength, network provider, etc. (Transparent connection to GSM module required)
------------------	---