

Manual

coM.sat ISDN Plus

Contents

Contents	2
List of figures	4
Versions.....	5
Abbreviations.....	6
Literature references.....	8
1 Introduction.....	9
2 User safety information	10
2.1 Electrical safety	10
2.1.1 Air traffic safety	10
2.2 Environment with explosive materials	10
2.3 Road traffic safety	10
2.4 Non-ionising radiation.....	10
2.5 Electronic medical equipment.....	10
2.6 Measures to be taken in case of loss/theft	11
2.7 Transport	11
2.8 Where to install the devices	11
2.9 Damage and repairs.....	11
3 Functional description	12
3.1 Starting up the device.....	15
3.2 Installation of the coMsat.exe application	17
3.3 Configuration of the coM.sat ISDN Plus	17
3.3.1 Interface.....	19
3.3.2 ISDN Configuration.....	22
3.3.3 GSM Configuration	25
3.3.4 Routing	27
3.3.4.1 Routing according to dialled number	28
3.3.4.2 Selection of providers by time and number	29
3.3.4.3 Callback Table and special routing.....	30
3.3.4.4 Automatically inserted country and area codes.....	30
3.3.5 Incoming calls.....	31
3.3.6 Outgoing calls.....	34
3.3.7 Fax/Data.....	37
3.3.8 Statistics	40
3.3.9 Voice	42
3.3.10 Unconnected Calls.....	44
3.3.11 Diversion.....	47
3.3.12 Virtual PBX	49
3.3.12.1 General Information	49
3.3.12.2 Configuration	50
3.3.12.3 Call Hold	51
3.3.12.4 Call Retrieve	51
3.3.12.5 Call Transfer	51
3.3.12.6 Licensing.....	52
3.3.13 Clock	53
3.3.14 Channel 1/2.....	55
3.3.15 Info	58
3.3.16 SMS	62
3.3.16.1 Receive SMS	63
3.3.16.2 Send SMS.....	63
3.3.17 Firmware.....	64
3.3.18 Terminal.....	66
3.3.19 Monitor Configuration	68
3.3.20 Monitor.....	70

3.3.21	Additional information	71
3.3.22	Vendor functions	72
4	Installation and operating information	73
4.1	coM.sat ISDN Plus replaces network termination	73
4.2	coM.sat ISDN Plus in TE mode	75
4.3	coM.sat ISDN Plus in router mode.....	77
4.4	Transmit SMS.....	78
4.5	Transmit a fax.....	78
4.5.1	Fax transmission via PC	78
4.5.1.1	Preparation of the PC for fax transmissions.....	78
4.5.1.2	Send fax messages	80
4.5.1.3	Receive fax message	81
4.5.2	Operating a fax machine on an extension	81
4.6	Data Transmission	81
4.6.1	Operating the PC at the serial port of the coM.sat ISDN Plus	81
4.6.1.1	Preparing the PC for the transfer of data.....	81
4.6.1.2	Sending and receiving data	82
4.6.2	Operating the PC as an extension	82
4.7	Servicing / Remote servicing	82
4.7.1	Servicing	82
4.7.2	Remote servicing	82
4.7.3	Read out/Transmit configuration	85
4.7.4	Software update	85
5	Questions and answers	86
6	Technical data	87
6.1	Connector assignments	88
Appendix 1:	LED Function	89
Appendix 2:	Terminal commands	90

List of figures

Figure 1: Functional Groups	13
Figure 2: Overview of the coM.sat ISDN Plus	14
Figure 3: Bottom side of the coM.sat ISDN Plus	14
Figure 4: Top side of the coM.sat ISDN Plus	15
Figure 5: coMsat.exe Installation.....	17
Figure 6: Interface	19
Figure 7: Interface	20
Figure 8: Automatic Load	21
Figure 9: ISDN Configuration	22
Figure 10: GSM Configuration.....	25
Figure 11: Routing	27
Figure 12: Incoming calls.....	31
Figure 13: Outgoing calls.....	34
Figure 14: Fax/Data.....	37
Figure 15: Statistics	40
Figure 16: Voice	42
Figure 17: Unconnected calls.....	44
Figure 18: Diversion	47
Figure 19: Virtual PBX.....	49
Figure 20: Clock	53
Figure 21: Channel 1/2.....	55
Figure 22: Module information.....	58
Figure 23: Module information in the terminal window.....	60
Figure 24: Unlock SIM card.....	61
Figure 25: Set prepaid credit.....	61
Figure 26: SMS.....	62
Figure 27: Firmware Update.....	64
Figure 28: Terminal	66
Figure 29: Monitor Configuration.....	68
Figure 30: Trace recording	70
Figure 31: Vendor Functions in channel 1/2.....	72
Figure 32: NT Installation	73
Figure 33: NT Configuration	74
Figure 34: TE Installation.....	75
Figure 35: TE Configuration	76
Figure 36: Router Installation	77
Figure 37: Install modem.....	79
Figure 38: Send Fax Wizard.....	80
Figure 39: Remote Servicing.....	83

Versions

Vers-No.	Date	Description of the revision	Chapter	Amended by
1.0	13/03/00	First issue	all	KTE
2.0	10/01/01	Complete review	all	KTE
2.1	08/02/01	Abbildung 1		KTE
2.2	26/04/01	CDC durch CIPC ersetzt	all	KTE
2.3	17/07/01	Aktuelle Photos eingefügt		IHA
3.0	12/02/02	Complete review f. V4.xx	all	KTE
3.1	07/08/03	Complete review	all	KG
3.2	14/01/04	Complete review	all	KG
4.5	07/09/05	Complete review	all	KG
5.0	23/03/07	Complete review	all	SJ
5.1	11/04/07	Complete review; Fax/Data via PC	all 3.3.7	SJ
5.2	17/07/07	VPBX usage option	3.3.12	SJ
5.3	01/08/07	CLIP list	3.3.6	SJ
5.4	21/09/07	Return Call Announcement	3.3.10	SJ

Abbreviations

EEPROM	E lectrical E rasable P rogrammable R ead o nly M emory: Memory circuit, which can be deleted by applying an electric voltage.
I ² C - Bus	I nter - IC B us
GSM	G lobal S ystem for M obile C ommunications
SIM	S ubscriber I dentify M odule
SMS	S hort M essage S ervice
SMSC	S hort M essage S ervice C entre
ISDN	I ntegrated S ervices D igital N etwork
TC System	Private telecommunications switching system
NT - Mode	N etwork T ermination: in this case, the device is operated as a network terminal (NT), whereby both the electrical and physical parameters (Layer 1) are adapted as well as the accepting the data link service and addressing tasks for layers 2 and 3.
TE - Mode	T erminal E quipment: In this case the device is operated at the TC system like a TE2 device i.e. like an ISDN - compatible terminal.
P - P	P oint - to P oint: direct communication between two points in a network with each other. Communication is solely via this connection. The point-to-point connection is a variant of the wiring of the S ₀ interface, if only one terminal is available.
PMP	P oint-to- M ultipoint, the point to multipoint connection is the other variant of the configuration for the S ₀ bus. In this case several terminals (max 8) can be connected to the same connection. Of these 8 devices, 2 can establish a connection at any one time.
S ₀	The S ₀ interface is an internationally standardised interface for ISDN installations. This interface is made available by the NTBA on the line side. On the customer side, the interface is provided both for the connection of a telecommunications switching system (→ system connection) as well as for the connection of up to 6 ISDN devices (→ multiple device port).
EDSS1	Name of the Euro-ISDN protocol (European D-channel Signalling System No 1); was introduced with the transition of national ISDNs to the whole of Europe, whereby a data link protocol was introduced, which is supported by all the connected states. This protocol contains the mandatory performance characteristics, which control the establishment and clearance of a link, as well as providing several supplements. National network providers can extend these performance characteristics.

AOC	Advice of Charge: Performance characteristic of the EDSS1. Display of the connection charges incurred as tariff units according to the network provider's tariff during and at the end of a link that has been made.
RJ45	RJ45 is the name given to the eight-pole connector technique, which has a very simple but effectively working configuration. This connector technique is used in the ISDN wire range for the So connection. The connector is standardised in ISO 8877.
MSN	Multiple Subscriber Number → multiple subscriber number for a multiple device connection.
PBX	Private Branch Exchange

Literature references

Bergmann / Gerhardt	Taschenbuch der Telekommunikation Fachbuchverlag Leipzig
Kanbach / Körber	ISDN - Die Technik Hüthig Verlag
Siemens	TC35 - Documentation

1 Introduction

coM.sat ISDN Plus is a digital mobile phone adaptor (TA) which uses suitable GSM modules and SIM cards for voice, data and FAX communications and SMS transmissions. **coM.sat** ISDN Plus is connected to the external or internal ISDN (S₀) - port of an ISDN PABX. The **coM.sat** ISDN Plus mobile phone adaptor can then be accessed from each extension user. Conversely, each extension connected to the PABX can be reached from GSM mobile phones at the most favourable mobile phone tariff via the **coM.sat** ISDN Plus mobile phone adaptor.

The **coM.sat** ISDN Plus is assembled in a stable housing and is suitable for installation on horizontal or vertical surfaces.

coM.sat ISDN Plus is configured comfortably and user-friendly via the **coMsat.exe** Windows application. The devices can also be serviced remotely with the aid of this application. The application can run under Windows 98®, Windows 2000® and Windows XP® and should run on Windows ME® and Windows Vista® too.

The performance characteristics, functions and interfaces of **coM.sat** ISDN Plus are described in this document.

Furthermore, this manual also includes information on installation, use and diagnostics.

Users are explicitly requested to read the user safety information first.

The manufacturer reserves the right to make technical changes that serve the safety of the device and improve its operation.

Should you have any further technical questions, our hotline is available at +61 (0) 3 9016 3480.

Additional information is available from **rossking's** internet site:

www.rossking.com.au

Please note: This description applies to the **coMsat.exe** - Windows Application V3.1.2 (and newer versions) as well as the associated firmware for the **coM.sat** ISDN Plus (V5.1.3 and newer).

¹ DTMS - only 14 cent per minute from the german fixed telephone network

2 User safety information

The following information applies to the **coM.sat** ISDN Plus. As the cellular engines used in this device are manufactured by Siemens (TC35i), Sony-Ericsson (GM47) or Wavecom (WMOi3), we explicitly refer to these companies' respective safety regulations and operating manuals.

2.1 Electrical safety

The **coM.sat** ISDN Plus works with a nominal supply voltage of about 10 V. Furthermore, the device is connected to the S₀ local port of TAs. Therefore no further precautions are required to protect the user against high voltages from this device. However, it should be noted that the user must ensure that they discharge any static charge they may have before working on the device.

2.1.1 Air traffic safety

Use of cellular engines in aircraft can impair their navigation systems and interfere with the mobile radiophone network. Their use has therefore been forbidden by law. The **coM.sat** ISDN Plus must therefore not be used on board aircraft. Breach of requirement can cause temporary or complete suspension of the cellular engine services and / or legal steps to be taken against the offenders.

2.2 Environment with explosive materials

The **coM.sat** ISDN Plus is not approved for use in potentially hazardous atmospheres. The user is therefore advised not to use the TA close to such areas, which could be e.g. at petrol stations, in fuel depots, in chemical works or during blasting. Should this nevertheless be necessary, the user should take steps to ensure that no risk can occur.

2.3 Road traffic safety

If the devices are used in vehicles that are used in public road traffic, the national regulations for telephoning in vehicles applicable for the country in which the device is must be complied with.

2.4 Non-ionising radiation

As in all radio transmission devices, the user should note that it is advisable for satisfactory use of the devices and safety of the user that the device is only used in its normal operating position.

2.5 Electronic medical equipment

The operation of radio transmitters, which includes cellular engines, can impair the

function of medical devices that have not been properly shielded. Please ask advice of your doctor or the manufacturer of the medical device.

2.6 Measures to be taken in case of loss/theft

If the **coM.sat** ISDN Plus, the cellular engines or the SIM cards used are lost, inform your network provider immediately to prevent any misuse.

2.7 Transport

The packaging ex works is designed to protect against mechanical damage and should be stored for any later transports. To avoid moisture condensation, time must be allowed for the devices to slowly adapt to the ambient temperature (if they have been stored in an environment with differing temperature) before starting them up.

2.8 Where to install the devices

The devices should be installed so that they are protected against direct sunlight and heat. This increases both the reliability of the operation of the devices as well as their service life, as the components used are less thermally stressed.

The devices should also only be used with the power supplies that they are supplied with or an original spare part.

The cables to the devices should be installed so that they do not cause any physical risk. Power cables should be installed separate from the signal cables.

The devices should only be installed by adequately trained personnel.

2.9 Damage and repairs

For safety reasons, the device should not be used in case of noticeable damage or if it has been exposed to moisture.

Repairs to the device should preferably only be carried out by the manufacturer or their authorised agents. Should this not be possible at any time, the repair must be carried out by an adequately qualified person, whereby only original parts should be used.

The device must be disconnected from the voltage supply before each repair.

3 Functional description

The **coM.sat** ISDN Plus connects the telephone system to the GSM network. The device can be operated both in NT mode as well as TE mode, namely either as a “point to point“ connection (P - P) or as a “point to multipoint“ (PMP) connection. It is connected to a local S₀ port of the telephone system.

coM.sat ISDN Plus is available as a one or two channel design. It is intended for use in the GSM 900 and GSM 1800 network, if suitable SIM cards are used.

The use of the Cellulare Engines TC35, GM47 and Wavecom WMOi3 not only enables voice communications, but also the transmission (sending and receiving) of data, faxes and SMS using a PC and the RS232 interface for direct access to the cellular engines. The most important user facilities of the TA are:

GSM services:

TS11	Voice, full rate and enhanced full rate, DTMF
TS12	Emergency call function
TS21	SMS, text and PDU mode
TS61	FAX Gruppe 3

Supporting services:

CLIP	Calling Line Identification Presentation
CLIR	Calling Line Identification Restriction
CFU	Call Forwarding Unconditional
AoC	Advice of Charge
BAOC	Block All Outgoing Calls
BOIC	Block Outgoing International Calls
BAIC	Block All Incoming Calls
COLP	Connected Line Identification Presentation

Hardware interfaces:

RS232	For programming and SMS	
RJ45	for connection to the TC system	ISO 8877
RJ45	for the synchronisation port and ISDN network	ISO 8877
	Cardholder for small 3V SIM cards	
BNC	RF links for the GSM antennas	
	Power Supply Connector	
	LEDs for displaying the operating condition	

Programming:

Configuration of the device settings via the Windows application **coMsat.exe**

Remote servicing for changes to the programming, software updates, and traces

Setting NT/TE mode via the configuration

Call charge information can be set between 0 and 240 seconds

Comfort suffix dialling (post selection dialling; positive and negative list)

Channel analysis and output of the signal quality

Loudness adjustment

To realise the above features, a microprocessors switching has been developed which controls the interaction of the various functional groups of **coM.sat** ISDN Plus. These are illustrated in the following sketch.

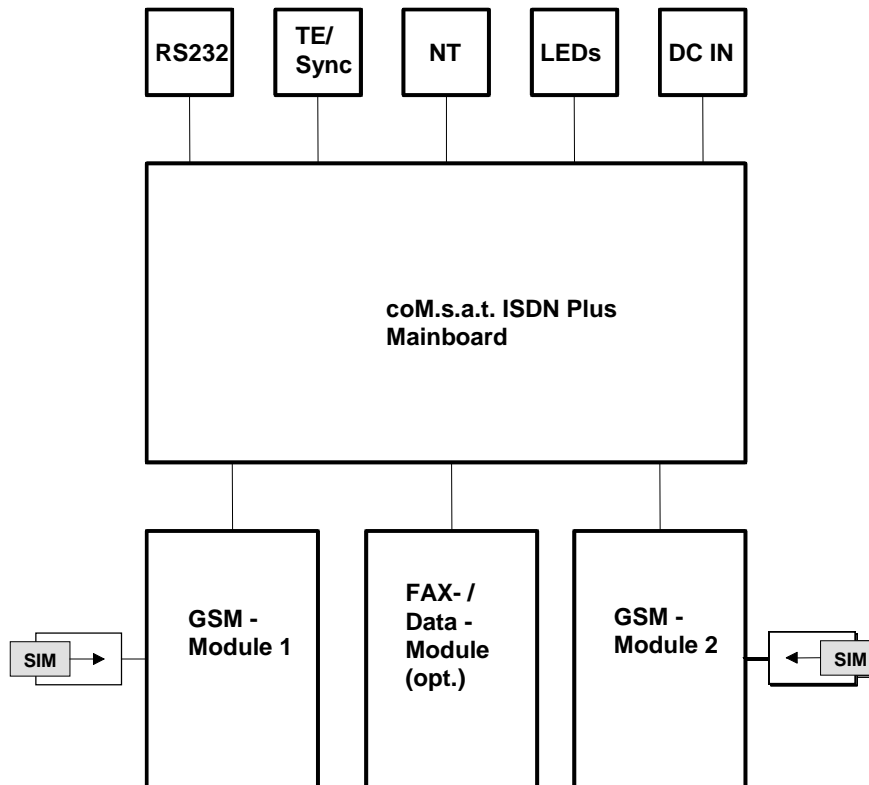

Figure 1: Functional Groups

Due to the modular design, the device can be delivered with one or two channels and with or without a data/fax module. The device is build up such that all connection elements are at the lower side and the SIM card holders are accessible on the upper side.

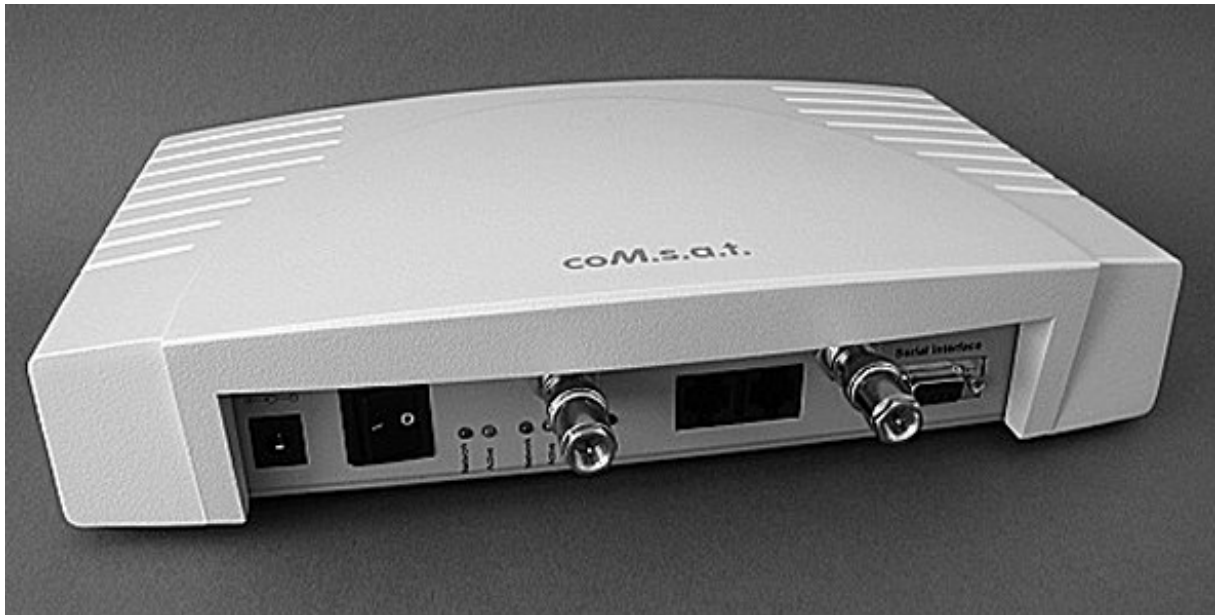

Figure 2: Overview of the coM.sat ISDN Plus



Figure 3: Bottom side of the coM.sat ISDN Plus

On the bottom side are located:

- the connector for the power supply
- the power switch
- the LEDs
- the jack for the NT connection (RJ-45)
- the jack for the TE connection or the synchronisation (RJ45)
- the connector for the serial port (RS232)
- the two BNC jacks for the antenna

The connections and significance of the LED's are labelled to prevent errors.

Before starting up the device, the SIM cards must be inserted into the provided holders. To access these holders, slider must be untightened and pushed to the front side of the device. This exposes two slots where the SIM cards can be inserted. Two 3V SIM cards are required for a two channel device, but usage with one SIM card is possible. In order to use the data/fax facilities, the SIM cards must have this feature

enabled.

To insert the SIM cards in the device, first push in the round yellow button next to the cardholder with a blunt, thin tool and then remove the cardholder. The SIM card is then placed in the cardholder and inserted into the card reader together with its holder. The contact area of the cardholder must be facing the rear of the device.

Attention: When pushing in the card, ensure that it does not fall out of the cardholder and that the card is correctly inserted in the cardholder guides. The device requires 3V SIM cards for operation!



Figure 4: Top side of the coM.s.a.t. ISDN Plus

3.1 Starting up the device

The SIM cards should be inserted into their reader slot first. Then the necessary cables are connected: Connection to the TC system as NT or TE, a connection to the PC's RS232 port on which the **coMsat.exe** application is installed, and finally the antenna cables.

Note 1: The GSM modules used in the **coM.s.a.t.** ISDN Plus for communication via the GSM network operate with an internal voltage of 3V. Therefore, for proper operation, SIM cards that can still operate with a working voltage of 3V must be used. All new SIM cards usually fulfil this requirement. If older cards (designed for a voltage of 5V) are used, the device possibly cannot log into the network - despite input of the correct PIN - because the SIMs cannot operate correctly at a voltage they weren't designed for.

Note 2: On the top side of the device, a slider hides the SIM card slots. If the screws are untightened, the slider can be pushed aside so far that the SIM card holders become visible. When looking at the front of the device, the left SIM card belongs to channel 1 and the right one to channel 2.

Once it has been installed, the device can be switched on after inserting the power jack. This is indicated by the red LED which is labelled "Power".

All the relevant parameters in the device are deleted in the factory before delivering the **coM.s.a.t.** ISDN Plus, so that it must be set for the individual installation. Therefore, when installing the TA for the first time, it must be configured using the **coMsat.exe**

application. To do this, a RS232 data link must be established between the **coM.sat** ISDN Plus and the PC on which the application is installed.

3.2 Installation of the coMsat.exe application

The coMsat.exe Windows® application is used to configure the **coM.sat** ISDN Plus. It is copied into a suitable directory on a PC together with two text files:

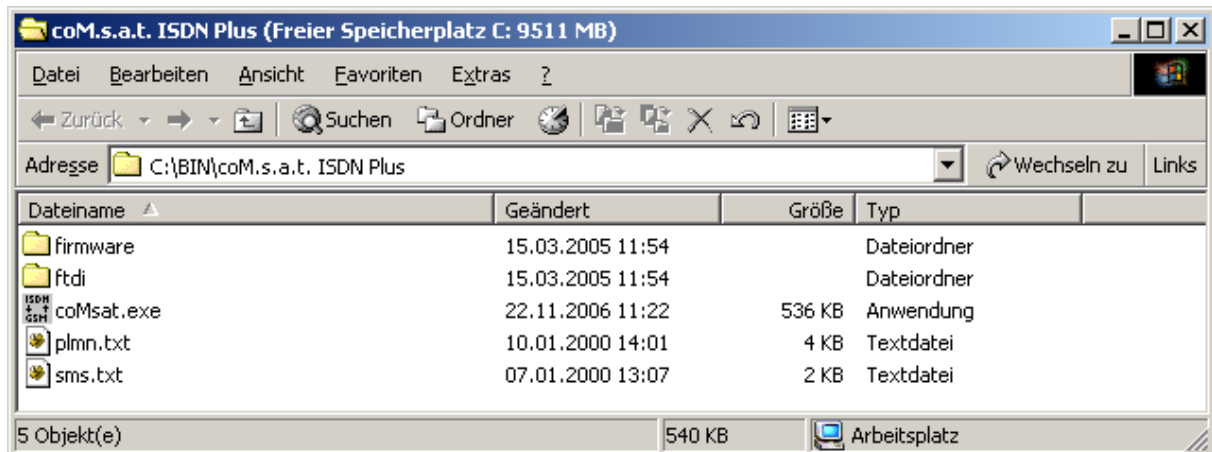

Figure 5: coMsat.exe Installation

The **coMsat.exe** application can now be executed from this directory or via a symbolic link that can be created manually e.g. on the desktop. A free RS232 port on the PC is required for operation with the **coM.sat** ISDN Plus.

3.3 Configuration of the coM.sat ISDN Plus

The **coM.sat ISDN Plus** is configured with the aid of the **coMsat.exe** Windows® application.

After starting the application by double-clicking the application's icon, the main application window is opened. Several file cards are displayed which control the various functions. These are supplemented by the typical Windows® application menus, such as **File, Connection, Configuration, Info, Firmware, Terminal, Monitor, View, and Help** and a symbol bar for quick access to the **New, Open, Save, Login, Logout, Load/Save Configuration, Load Monitor, Load Status** and **About** commands.

Various function groups are arranged on the file cards so that they form meaningful units. These are:

- Interface
- ISDN Cfg
- GSM Cfg
- Routing
- Incoming Calls
- Outgoing Calls
- Fax/Data

- Statistics
- Voice
- Unconnected Calls
- Diversion
- Virtual PBX
- Clock
- Channel 1
- Channel 2
- Info
- SMS
- Firmware
- Terminal
- Monitor Cfg
- Monitor

3.3.1 Interface

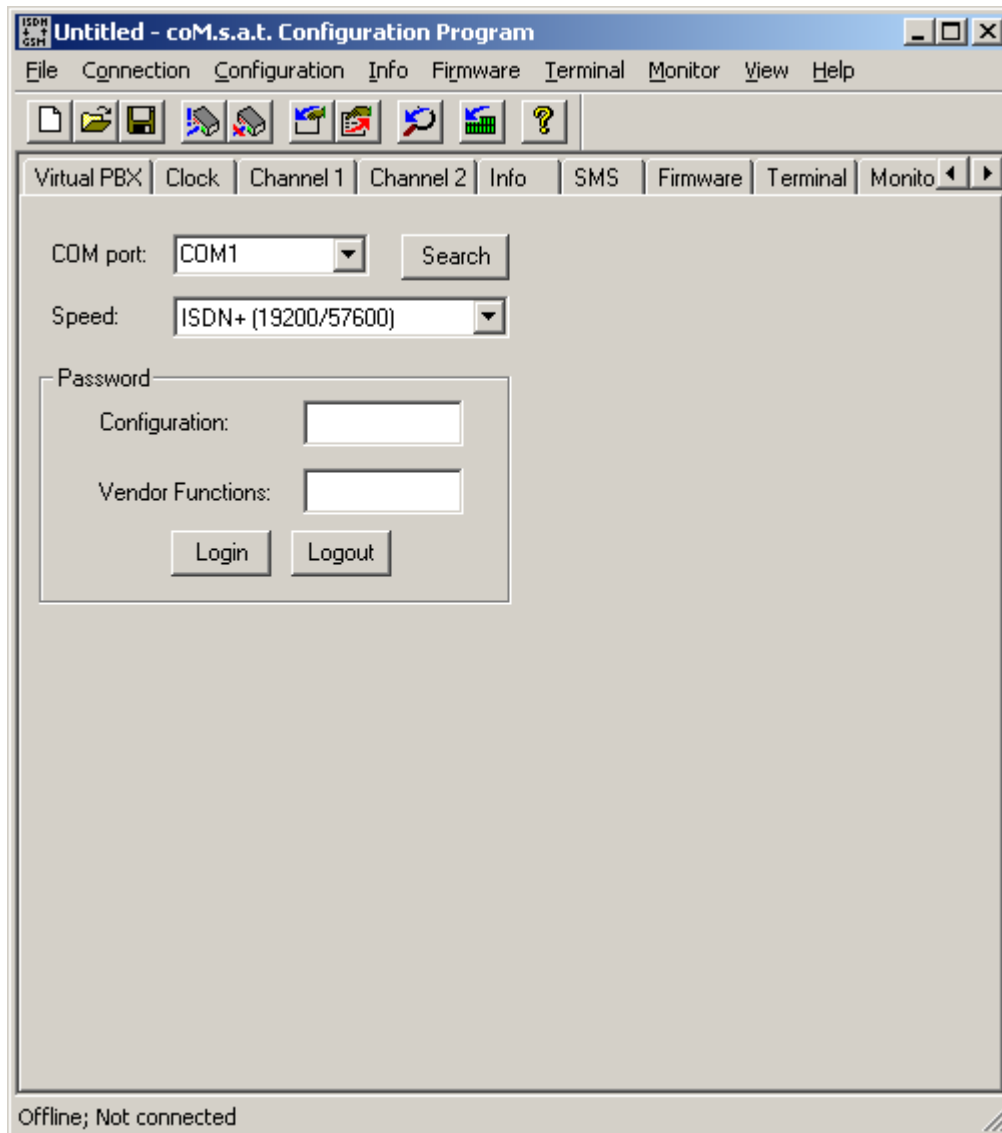

Figure 6: Interface

After calling up the **coMsat.exe** application, the connection to the device is made via the "Interface" tab. Upon clicking the tab marked "Interface" it will come to the foreground and its contents will become visible.

The PC interface which shall be used for the data link to the **coM.sat** ISDN Plus is selected using the "COM port" drop down list box. It is also possible to let the application choose the port itself, using the "search" button. Should the application be unable to find a connected **coM.sat** ISDN Plus, it will issue the message "No device found!".



Figure 7: Interface

Many functions require an authentication of the user. This is done by clicking on the "Login" button also located on this tab. The authentication is removed by clicking the "Logout" button. The termination of **coMsat.exe** automatically removes authentication. Therefore explicit logout is only required if **coMsat.exe** remains connected to the ISDN Plus after the user leaves it.

To prevent unauthorised persons from logging into the TA and altering the configuration, at least the configuration password should be entered in the "Password" box. Each password consists of max. 19 alphanumeric characters. The various function groups within the **coM.sat** ISDN Plus **coMsat.exe** application are then accessible with differing protection.

Users who do not know either of these passwords can carry out all the unprotected functions on the device. They connect to the device by calling up "Connection" on the menu bar and calling up "Go Online" in the menu that opens, or simply use the desired function. The applications then connects to the **coM.sat** ISDN Plus. In this mode, the device configuration can be read, but not altered. SMS can be sent and received and any SMS received can also be read. The same procedure applies to remote access to the device.

However, the configuration settings can only be altered by logging in with a configuration password. Then all configuration data can be read out, amended and resaved. The "Vendor Functions" password makes further functional blocks accessible, via which the various network operators can be authorised or excluded.

If a password is entered, this password is transferred to the TA together with the configuration data. The next time the TA is logged into, the password must first be entered in the relevant box.

A password can be deleted or altered after logging in by deleting the relevant box for the password or entering another password. The new password is then valid after the next update of the configuration.

The configuration data of one or several devices can be saved as usual in Windows®. The files contain the configuration, the firmware ID, the device information and the monitor contents, if these have been loaded before.

At the bottom of the **coMsat.exe** window there is a state bar which displays the current actions. The state of the link (online/offline) and the port of the PC via which the data is transmitted when a link is made (e.g. "Online (COM 1)") is displayed on

the left-hand side of the bar.

The “**Connection**” menu contains another command, i.e. “**Automatic Load**“. This command opens the following dialog:

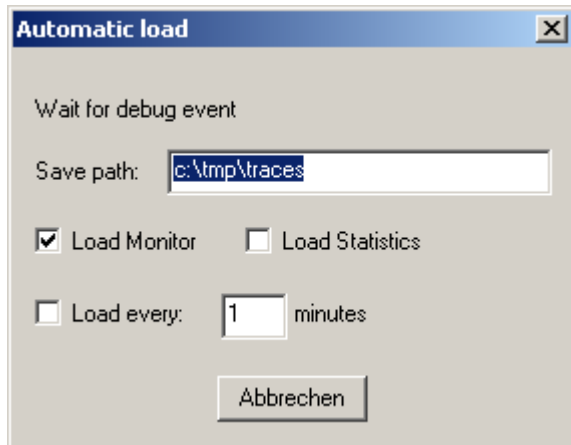

Figure 8: Automatic Load

As long as this dialog is open, **coMsat.exe** checks the messages from the device and starts an automatic load if it reports a restart. The load process can also be started periodically. To enable this, the option “**Load every ... minutes**” must be activated and the period set as desired. The automatic load loads the monitor, the statistics, or both, as selected by the options.

If the automatic load is done for monitoring a long period, the load timeout should last 3 – 5 minutes in order not to lose information. If only statistics is loaded, 1 hour is sufficient. To load the statistics, a login must be possible so the passwords must be entered correctly. The automatic load function logs in before loading the statistics, even if already logged in. This is done because a restart might have caused a logout and then the statistics could not be loaded anymore.

3.3.2 ISDN Configuration

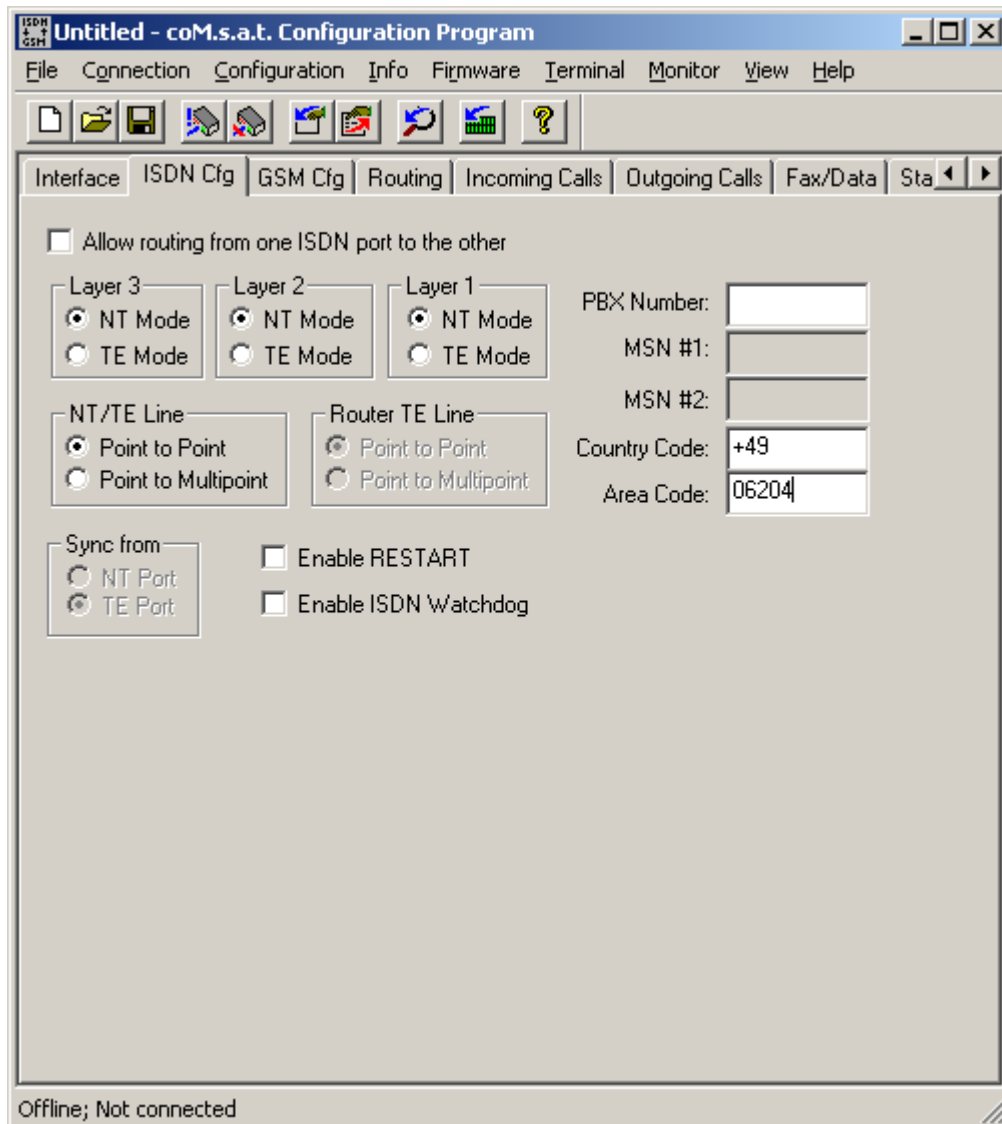

Figure 9: ISDN Configuration

The settings required for operation with the telephone system are made in the "ISDN Cfg" tab. When configuring the ISDN link, layers 1 to 3 are independently set for operation of the **coM.sat** ISDN Plus in NT or TE mode.

NT-Mode operation

In this mode the device presents itself to the telephone system as the ISDN network operator's network terminator. The connection to the **coM.sat** ISDN Plus is set up as a point-to-point or point-to-multipoint connection.

If the telephone system additionally has a fixed network connection and it reports too many errors (frame slips, bit slips), a synchronisation may be necessary. These types of errors are unimportant for voice communications. However, in mostly larger TC systems with more elaborate trouble shooting procedures, problems can occur during operation that can cause this “faulty” port being switched off. This can be avoided by synchronisation. In this case, the synchronisation input of the **coM.sat** ISDN Plus is connected directly with the system port (fixed network). The synchronisation clock is then derived from this signal.

The PBX number entry also depends on the telephone system. Some systems do not require an entry here. As the entry of Multiple Subscriber Numbers isn't necessary in NT-mode, their respective boxes are inactive.

TE-Mode operation

If the **coM.sat** ISDN Plus is to be used in TE-mode, that is like a simple extension, then click the corresponding radio button for layer 3. Layers 2 and 1 will automatically be set to TE-mode. In this mode (operating on the telephone system's internal S0 bus) there is usually a point-to-multipoint connection. Therefore the line type is automatically set to this type of connection.

It is also often necessary to identify those extensions (Multiple Subscriber Numbers 1 and 2) via which the device is identified by the telephone system. Both GSM channels may be addressable by the same MSN if supported by the telephone system. If at least one MSN is empty, the device accepts any called party number and uses that number for the outgoing call. This means that the MSN is dialled via GSM, which is usually not desired. This function is useful if there is a diversion or VIP number programmed for each possible MSN, so that the MSN is converted into a valid GSM number.

If used in TE-mode, as terminal equipment, no synchronisation is necessary.

Router operation

If the **coM.sat** ISDN Plus shall be able to route calls from one ISDN port to the other, then activate the box labelled “**Allow routing from one ISDN port to the other**”. Layers 3, 2 and 1 will automatically be set to NT-mode because this reflects the setting of the ISDN port labelled “NT”. The line type automatically changes to point-to-point connection. The mode of layers 2 and 1 and the line type may be changed subsequently, but layer 3 of the NT port remains in NT mode, layers 3 to 1 of the TE port always operate in TE mode, and the line type setting applies to both ports.

The PBX number entry also depends on the telephone system. Some systems do not require an entry here. As the entry of Multiple Subscriber Numbers isn't necessary in router mode, their respective boxes are inactive.

The ISDN line monitoring is activated via the “**Enable ISDN Watchdog**” option box. In this case, if faults are registered in the ISDN layers 1 or 2, a warm restart is carried out approx. every 100 seconds.

The “**Enable Restart**” checkbox defines whether or not the **coM.sat** ISDN Plus sends the telephone system a restart command after a cold start or reset. Usually this option need not be set. It can be set to terminate any active calls after a restart of the device, but there are also TC systems that do not react on restart messages and thus

make the **coM.sat** ISDN Plus inaccessible until a timeout terminates the restart procedure.

The country and area code are set in separate input boxes. The country code is the international dialling prefix (e.g. "+49"). The area code is usually the prefix for phone numbers in the same town that the TA is located and is therefore omitted when calling a number in the same area (e.g. "06204"). Entering these numbers at this point saves you the effort of entering them during later definitions of number lists (e.g. Net Access Numbers).

If not otherwise specified, the **ISDN Plus** assumes that international calls start with "00" (or "+") and national calls start with "0". These settings can be modified by appending the correct setting to the country and area code separated with a slash (e.g. "+1/011" as country code and ".../1" as area code for USA and Canada).

The current configuration of the **coM.sat** ISDN Plus can be enquired by clicking on "**Configuration**" in the menu bar and then selecting "**Query**" from the menu. Alternatively, the short cut keys

<Alt> <C>

and

<Q>

can be used or the button "Query Configuration" in the toolbar can be pushed.

After entering a new configuration or altering the current configuration, this can be saved via the "**File**" menu or can be transferred to the **coM.sat** ISDN Plus via the RS232 data link. This is done either via "**Update**" in the "**Configuration**" menu or by pushing the toolbar button "Update Configuration" or by entering the relevant keys on the keyboard.

A configuration file that has already been stored can be loaded again using the file menu and transferred to the device as described.

3.3.3 GSM Configuration

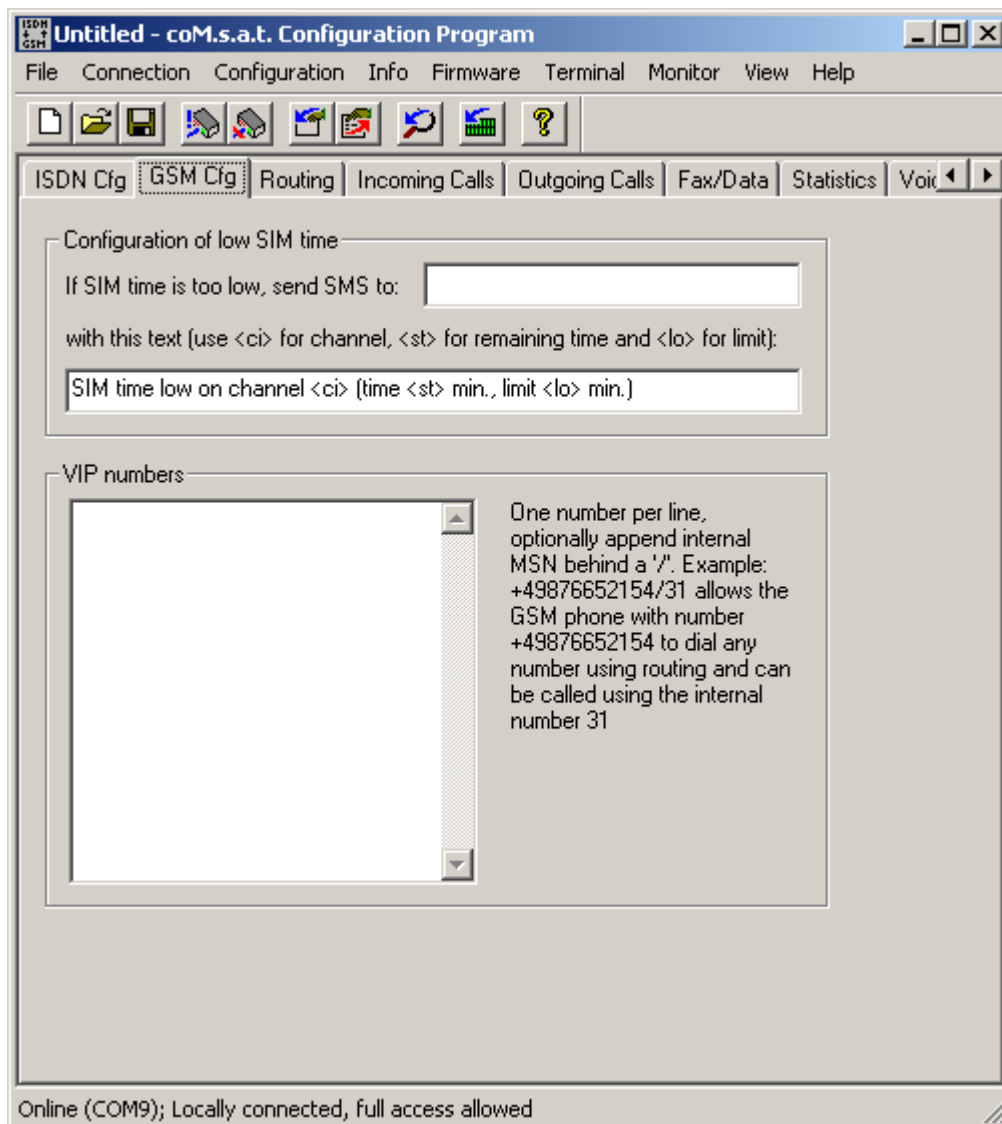

Figure 10: GSM Configuration

This page is used to configure GSM specific options.

The **coM.sat** ISDN Plus implements a time based supervision of prepaid credits. The credits themselves are dynamically programmed using the command “Set Prepaid Time“ in menu “Info“, which is described in chapter 3.3.15. Each channel is programmed a separate threshold, see chapter 3.3.14. If the credit falls below that threshold, the channel is not used anymore. The GSM configuration on this page configures additional behaviour in this case.

A GSM phone number can be programmed which shall receive an SMS if the credit becomes low. If no number is programmed, no SMS is sent. If a number is

programmed, the second input field determines which text is sent with the SMS. This text allows three place holders:

- <ci>: Is replaced by the number of the channel with low credit
- <st>: Is replaced by the remaining time credit
- <lo>: Is replaced with the programmed threshold

The VIP number list “**VIP numbers**” contains GSM phone numbers that get a special treatment. Each line contains a phone number and may also contain an MSN in the format <GSM number>/<MSN>. The MSN may be used to define short numbers for the members of the VIP list. If this MSN is called from any source (i.e. NT, TE or GSM), the call is connected to the associated GSM phone number. If a call comes in from a VIP number, the associated MSN is transmitted as calling party number in the ISDN messages.

VIP users always have the right to dial in even if the channel’s dial in option is switched off (“Call Default”, see 3.3.14). This allows to define a specific user group that may dial any number while normal users only call the default extension.

VIP users also use the routing function (see 3.3.4). While normal users calling from GSM are always connected to the PBX, VIP users may also call to PSTN or GSM depending on the called number and the programmed routing.

If a VIP number is called, the calling party number (the number belonging to the SIM card) is always shown to the VIP user, even if the channel in use has the option CLIR enabled, thus suppressing the number presentation. This does not enable the use of the return call handling in this case, because then a VIP won’t be able to use the VPBX anymore if a return call is stored for him.

The functions of the virtual PBX are also accessible to VIP users (see 3.3.12). Thus all GSM users contained in this list can use all functions normally available only to PBX extensions. Therefore these phone numbers are also called virtual extensions.

Note: The device uses the country and area code settings for the GSM number so that only one notation of a number need to be entered in the list.

3.3.4 Routing

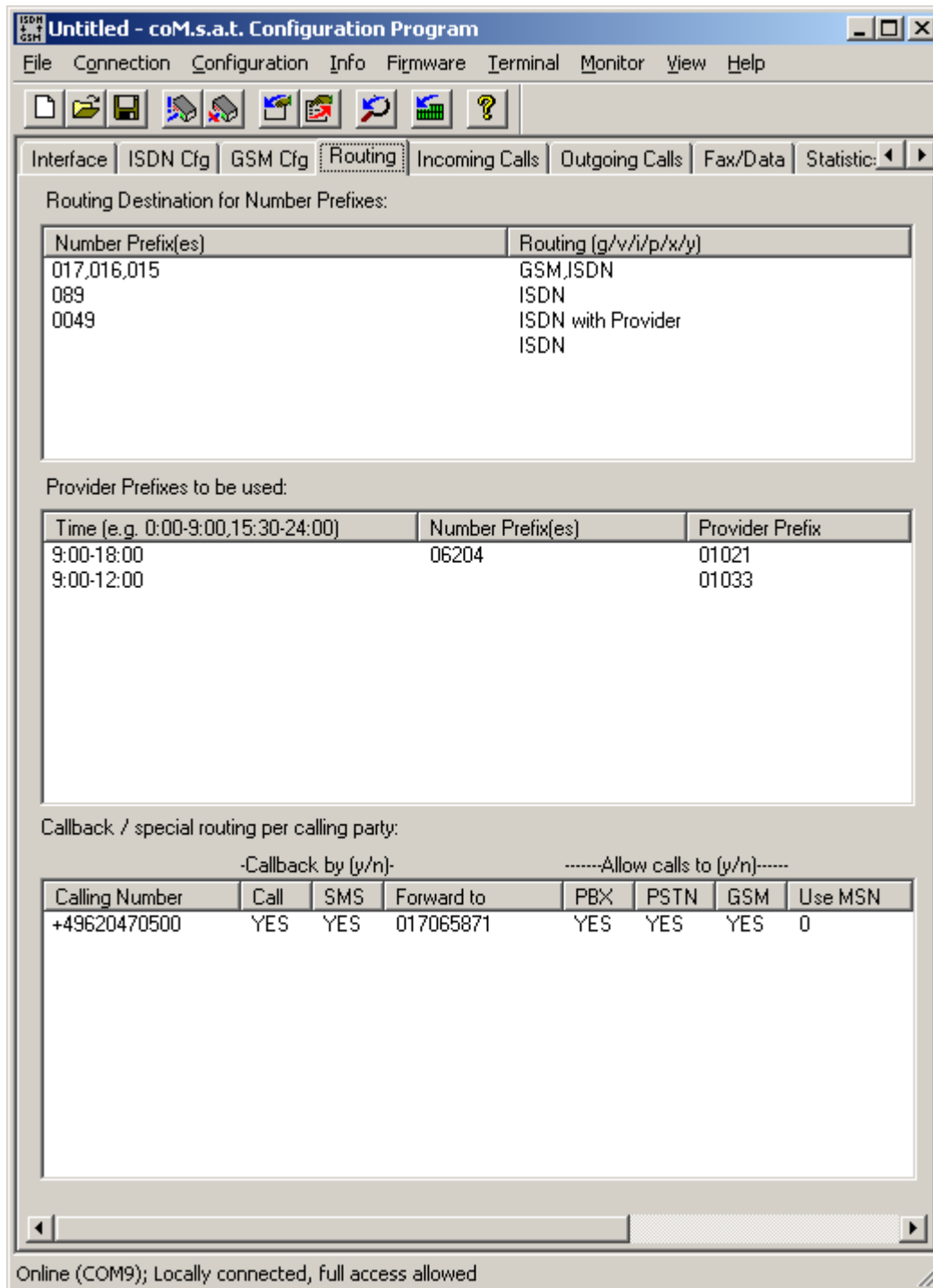

Figure 11: Routing

3.3.4.1 Routing according to dialled number

The table “Routing Destination for Number Prefixes“ determines if GSM (with or without provider) or ISDN (with or without provider) is to be used. Special cases also require the setting of a routing for calls to the PBX (with or without provider).

Example:

Number Prefix	Routing
017, 016, 015	GSM, ISDN
089	ISDN
0049	ISDN with Provider
	ISDN

This table is parsed from top to bottom, comparing the prefix with the called number. If the number’s first digits match the given prefix, the routing is evaluated. If “GSM” is specified, a GSM channel is selected according to the “Net Access Numbers“ settings, optionally inserting a provider. If “ISDN” is specified, the call is routed to PSTN, again allowing the insertion of a provider prefix, just like the specification of “PBX” which causes a routing to the TC system. If more than one route is specified and the first one is not able to route to call, the second option is evaluated. If e.g. “GSM,ISDN” is specified and there is no GSM channel available at the moment, the call is routed to ISDN (“fallback”). If in this case only “GSM” would have been specified, the call would be rejected.

The example above causes the following behaviour:

- All calls to typical (german) GSM numbers are routed via GSM if possible, and via ISDN otherwise
- All calls to Munich (089) are routed via PSTN without provider prefix
- All other calls to german numbers (+49) are routed via PSTN with a provider prefix
- All other calls are routed via PSTN without provider

In addition to numbers, the place holder “?” can be used to specify any number. This is especially useful if numbers can only be distinguished by their length. This applies e.g. to internal MSNs and local area numbers. The following example assumes that all internal MSNs are two digits long:

Number Prefix	Routing
017, 016, 015	GSM
???	ISDN
??	PBX

This routing table works like this: All GSM numbers are routed via **GSM**. If any number with only two digits is dialled, only the entry number 3 matches, because all other entries require at least 3 digits. All numbers with more than two digits not matching the first line are routed to the ISDN network.

The table is split into two columns and the entries are directly edited in the list box. A double click on an entry makes it editable. By using the “Page Up” and “Page Down” keys, the edit field can be moved to the next or previous column. The cursor up and down keys move the edit field one line up or down in the same column.

If the list box has the input focus but no entry is edited, the insert key allows to create a new line above the first currently selected line. All selected lines can be deleted using the delete key. Ctrl-C copies selected lines to the clipboard just like Ctrl-X which also removes the lines afterwards. Ctrl-V inserts lines from the clipboard above the first selection or at the bottom of the table if none is selected. A selection can be removed by left click with pressed control key as usual in multiple selection list boxes. Tab and shift-tab can be used to jump to the next or previous dialog element, as usual.

The second column only allows to use the keys “i”, “g”, “p”, “v”, “x”, “y”, backspace, cursor left/right and delete. “i” inserts “ISDN”, “g” inserts “GSM” and “x” inserts “PBX” at the current insert position. “p”, “v” and “y” do the same with the option of inserting a provider prefix. The cursor can only be positioned at the beginning and end of words. Delete and backspace always delete complete words.

Empty lines are removed automatically before the configuration is updated.

3.3.4.2 Selection of providers by time and number

The table “Provider Prefixes to be used“ defines which provider should be used for those numbers that are routed with provider specified in the first table. This table is ignored otherwise.

Example:

Time	Number Prefix	Provider Prefix
9:00 – 18:00, 20:00 – 22:00	0241,0621	01021
9:00 – 12:00		01033
12:00 – 18:00		01013
18:00 – 20:00		01051
0:00 – 24:00		01070

This table is parsed from top to bottom, comparing the current time to the times specified in the first column and the called number to the prefix in the second column. An empty entry in the number prefix column matches any number. If both entries match, the provider specified in this line is used.

The first line in this example defines a specific prefix for specific area codes. The last line in this example causes all numbers not matching one of the entries above to be routed using the prefix 01070.

If no entry matches, the call is rejected.

This table is displayed in three columns that are edited the same way as the first table, except that there is no special editing as in the second column of the first table.

3.3.4.3 Callback Table and special routing

The last table on this page allows to call back special GSM numbers on request. The callback can be initiated either by a call (which is rejected) or by an SMS, depending on which method is allowed in the columns "Call" and "SMS" by entering "yes". If a callback by SMS is allowed, it is sufficient to receive an SMS from that GSM number. If the SMS contains a number, it is stored as desired number to be called.

If the callback is accepted by the GSM user, he usually gets a dial tone and can dial a number to one of the allowed destinations. If the channel used does not allow dialling ("Call Default"), there is no dial tone and the call is forwarded to the number configured in column "Forward to". If the callback was done due to a received SMS and the SMS contained a number, there is no dial tone either and that number is called.

If one (and only one) line has an empty "Calling Number", this line matches any call without CLIP. These callers never get a dial tone but are always forwarded to the number configured in column "Forward to".

This table can also be used to configure a default number different from that in the channel settings. The number configured in column "Forward to" supersedes the number of the channel settings and is called if that special GSM user is calling and nothing is dialled or dialling is not allowed. This is also true if no callback is allowed, so that the entry only assigns a different default number.

Additionally, the table can prevent certain callers from calling specific destinations. If a calling party number matches an entry in the callback table, those destinations in the routing table not allowed by this entry are removed from the possible routes.

3.3.4.4 Automatically inserted country and area codes

The own country and area code is programmable on the dialog page named "ISDN Cfg". This enables the router to find matches in the tables even if the table entries are specified with these codes and called numbers are lacking them. It is also possible to specify the tables without these codes and called numbers with these codes will still match. This eliminates the need for specifying all possible number representations.

3.3.5 Incoming calls

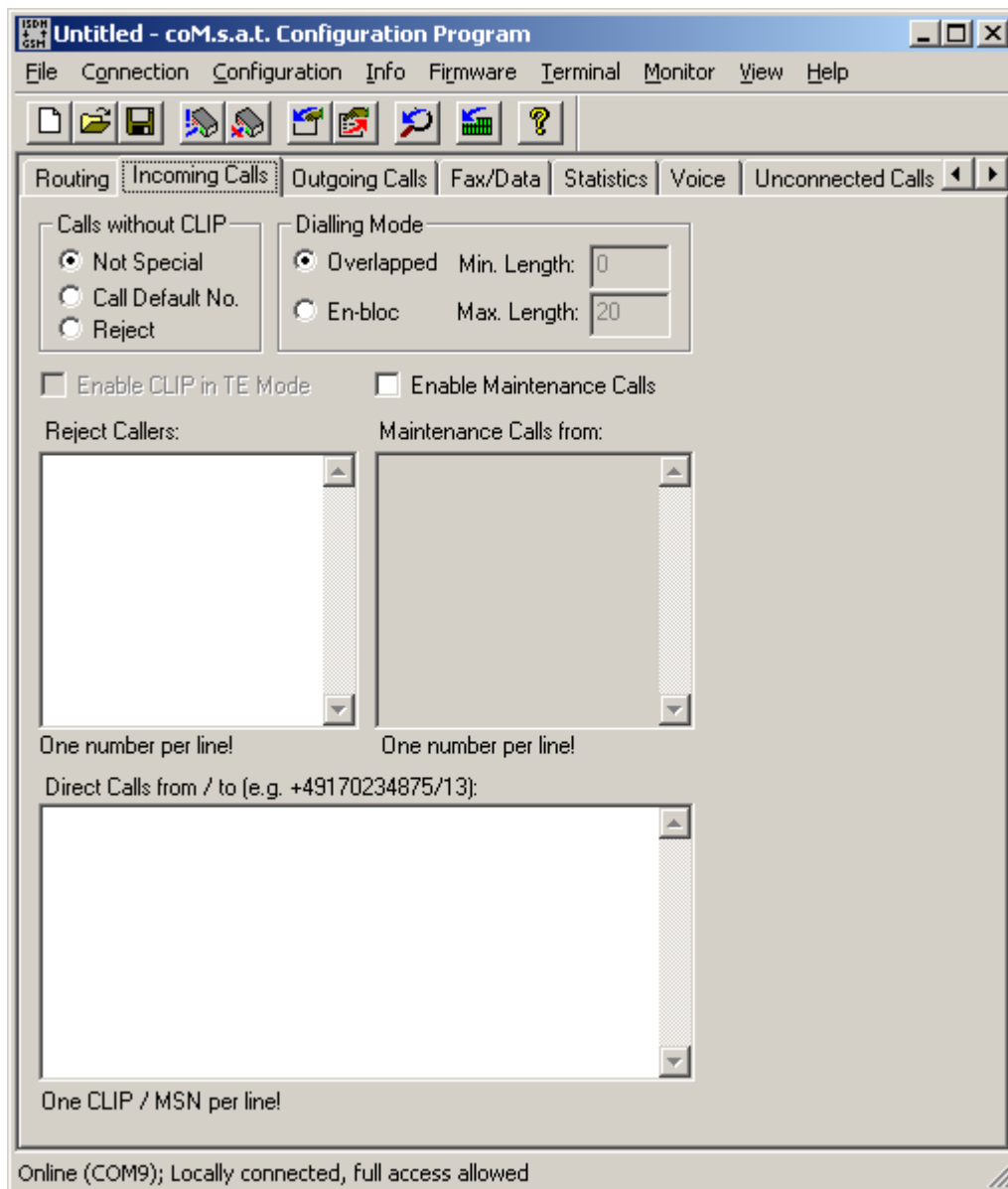

Figure 12: Incoming calls

The configuration for incoming GSM network calls is set up via the “**Incoming calls**” card. First set up how “**Calls without CLIP**” are dealt with. These calls can either be transferred to a particular extension (“**Call Default No.**”), which is determined during configuration of the GSM channels, or **rejected**, or dealt with in the same way as all other calls (“**Not Special**”).

The dial in behaviour on calls from GSM is further specified by the option “**Dialling Mode**”. “**Overlapped**” means that incoming calls are immediately reported to the PBX without any dial information. The PBX requests more information and the call is

connected. Each dialled digit is immediately forwarded to the PBX which terminates the dial procedure as soon as it has enough information to call an extension.

This is different if “**En-bloc**” dialling is selected. Then the **coM.sat ISDN Plus** connects the call without contacting the PBX. This is done after the called number has been completely received. Since the device does not know the numbering plan of the PBX, it can not determine from the called digits if a number is complete. This is detected either by having received as much digits as specified by “**Max. Length**” or if no more dial information is received for as long as configured in “**Incoming call dial timeout**” in the channel settings. If less than “**Min. Length**” digits is received, the call is rejected.

The option “**En-bloc**” has to be used if the PBX does not support overlapped dialling. If no PBX is connected, but only some phones on a bus, this is almost always necessary. If using overlapped mode and incoming calls which should be able to dial do not get a dial tone, but one or more phones start ringing immediately, this indicates that the “**En-bloc**” option is needed.

A further option (“**Enable CLIP in TE Mode**”) can also be selected in this card, but it can only be accessed if the TE mode has been set. You can then choose whether the caller’s number is to be transmitted or not. If this box is checked, the **coM.sat ISDN Plus** tries to transmit the number calling from within the GSM network - provided the telephone system it is connected to supports this feature.

The option “**Enable Maintenance Calls**” determines the handling of GSM data calls. If the option is switched off, all data calls are ignored. If it is enabled, these calls can be connected in order to perform remote maintenance. If the list “**Maintenance Calls from**” is empty, all data calls are connected. If there are numbers in this list, only data calls from these numbers are connected for remote maintenance.

Callers can also be rejected by the **coM.sat ISDN Plus**. The relevant phone numbers are entered in the “**Reject Callers**” list box. Only one phone number is entered in each row. The number of the caller may be longer than the number in the list, so multiple callers with the same prefix can be rejected with a single entry.

The telephone numbers of callers that are to be transferred directly to specific extensions can be entered in another list (Direct Calls from / to). The callers must have activated Calling Line Identification Presentation (CLIP) in their phone in order to utilise this feature. The entries must be entered in the form: <international phone number><national dialling code><phone number>/<MSN>.

Example: +4962171481430/22

Note: Both lists use the country and area code settings so that only one notation of a number need to be entered in the lists.

The length of the lists only depends on the amount of internal memory. A storage area of 32 kByte is available for the lists and configuration parameters. A 10 - digit number occupies 10+1 bytes of memory, moreover a few additional bytes are needed for the termination of the lists. It is up to the user to decide which lists are important and need to be enforced. It is entirely possible to use one and only one of the definable lists with the maximum length or to use all lists with an accordingly

reduced length. In the latter case the lists each have a length of approximately 70 entries.

3.3.6 Outgoing calls

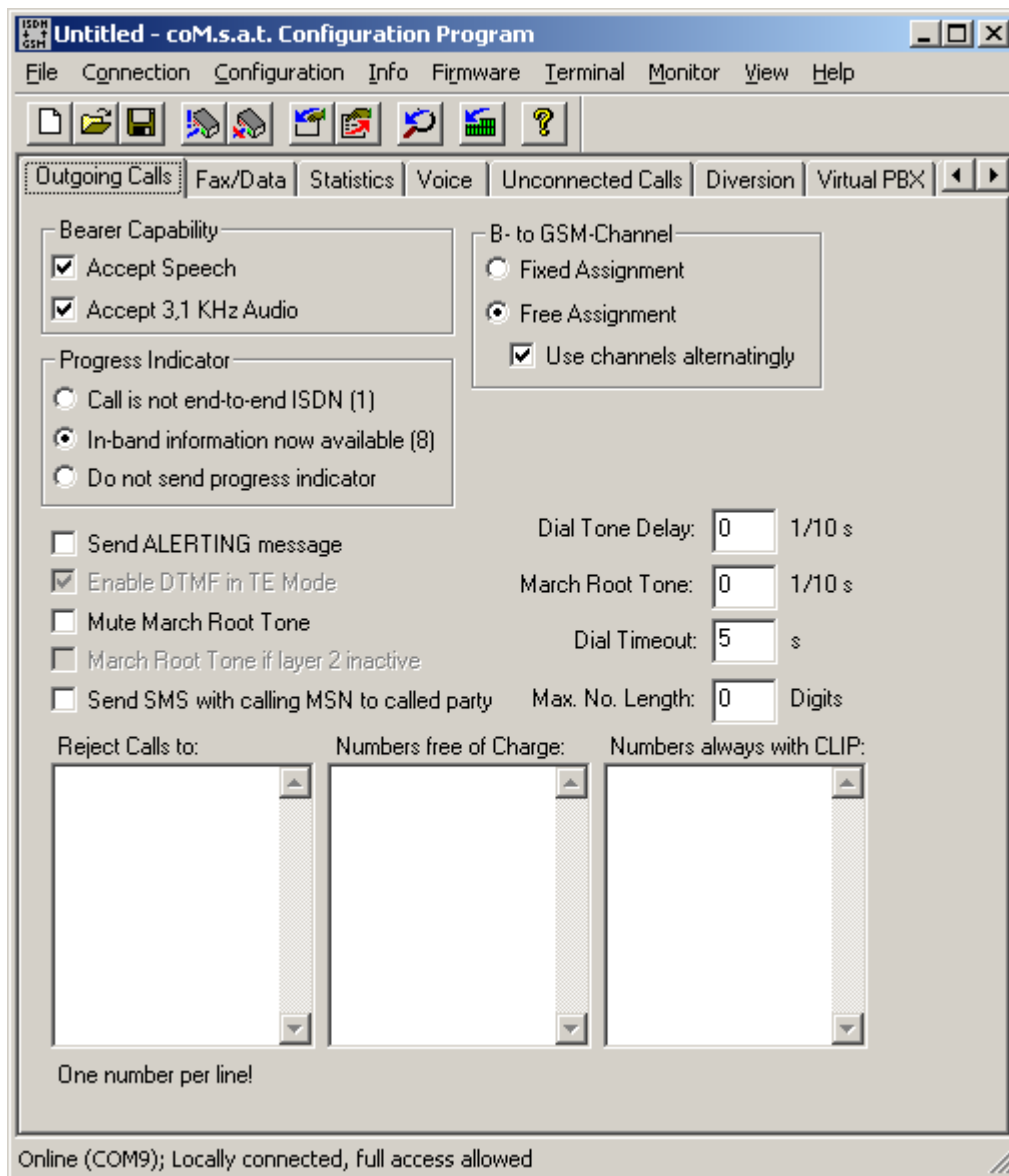

Figure 13: Outgoing calls

A separate card is provided for the configuration of outgoing calls in the same way as for incoming calls.

The type of speech communication is selected in the “**Bearer Capability**” box of this card. The “**Accept Speech**” option should then be selected if the **coM.sat** ISDN Plus is connected to a telephone system to which only ISDN telephones are connected. If analogue telephones are also used, both options should be selected. On the other hand, no speech communication is possible if both options are deactivated. This makes sense if only SMS is to be exchanged.

The assignment of the B-channels to the GSM channels is then defined in the “**B to GSM Channel**” box. Fixed assignment determines that the first B channel is

assigned to the first GSM channel. Fixed assignment of the channels can be useful if e.g. different network providers are to be used for the two GSM channels. If the channels are freely assigned, the call is assigned to the first free channel. If one channel is busy, the other is used. In the case of free channel allocation there is the additional option "**Use channels alternatingly**". The GSM channels are selected alternatingly. This feature can be used to balance the load (the cost) evenly between channels. If this box is not checked, there will be a bias towards one channel!

The "**Progress Indicator**" setting influences the value of an ISDN information element. The first value "Call is not end-to-end ISDN" informs the connected PBX that its call uses a different network to be connected. The other value "In-band information now available" informs the PBX that an announcement or a tone is available and must be transferred to the calling user. This value is usually needed for correct operation, whereas the first value may be needed by specific PBXs. If the progress indicator causes a problem in the PBX, it is possible to switch it off completely with the third option "Do not send progress indicator".

The "**Dial Timeout**" is the time that may pass between the last digit of the phone number being dialled and the selection process is passed into the GSM network. This time is usually set to 5 secs. It can be reduced to 1 second. The maximum possible setting is 10 secs. The time between dialling the last digit and hearing the dialling tone can be reduced by reducing this time.

Note: In some telephone systems, dialling can also be concluded by pressing the "#" key. In this case there is no waiting time.

The "**Send Alerting Message**" option is used to set whether the "**Alerting**" message is generated by coM.sat ISDN Plus for calls to PBX. If this option is selected, the "**Alerting**" message is inserted by coM.sat ISDN Plus for an outgoing call after the "**Setup**". If the option is not activated, the "**Alerting**" message is suppressed and the call is continued with "**Call Proceeding**". Use of this option also depends on the properties of the connected telephone system.

coM.sat ISDN Plus always generates the dialling tone (exchange dialling tone) itself and transfers the ringing tone or the network provider announcements to the B-channel. Whether the ringing tone or the network provider announcements from the GSM network are used in the B-channel or the ringing tone generated by the telephone system is used now depends on whether the "**Alerting**" option has been activated or is passive.

The "**Enable DTMF in TE Mode**" option must be used if the coM.sat ISDN Plus is connected to a PBX in TE mode which does not support overlapped sending of dial information (which is the usual case). Then the GSM number is dialled with the aid of DTMF tones.

The "**March Root Tone**" serves to bridge delays with a tone or sequence of tones in order to prevent the impression that the line is "dead", particularly during the call setup. The TC35i modules produce the "march root tone" on their own. If the tone of the ISDN Plus is to be used, the tone of the TC35i module should be switched off. The duration of the tone is set in the input box: 30 represents a tone of 3 seconds duration.

The parameter "**Dial Tone Delay**" can be used in applications that rely heavily on block dialling. Some PBXs do block dialling in two steps. First they initiate a call without number so that the ISDN Plus generates a dial tone. Then they send the called party number which stops the dial tone again. This can be prevented using "**Dial Tone Delay**", delaying the dial tone by multiples of 0.1 seconds. The dial tone is only started if no dialled number is received during that time.

If the GSM network always uses the same length for its phone numbers, the parameter "**Max. No. Length**" can be set to this length. This instructs the **ISDN Plus** to start the outgoing call immediately after that number of digits have been dialled, without waiting for timeout.

The March-Root-Tone generated by the TC35i module can be suppressed by checking "**Mute March Root Tone**".

Enabling the option "**March Root Tone if layer 2 inactive**" causes a march root tone to be generated if a call is routed to an ISDN port with inactive layer 2. Since it may take a while to activate layer 2, the calling user would not hear anything for a while and might hangup. This can be avoided with this option.

The option "**Send SMS with calling MSN to called party**" causes an SMS to be sent for calls from PBX to GSM containing the MSN of the caller. This allows the called user to see who calls him during an active or after a missed call.

The possible settings for outgoing calls are then rounded off by three lists.

The phone numbers that are not to be dialled are entered in the first list, e.g. very expensive numbers that start with 0190x. If no country and area code is specified, the phone number must be entered both with and without the dialling code to avoid being able to call restricted numbers by using or omitting these codes.

Example: 71481430
 062171481430
 +4962171481430

However, if the country code "+49" and the area code "0621" is configured, only one entry of the three above is necessary.

The comparison of the numbers begins at the first position and need not match completely. Entries in this list can therefore be prefixes.

The second list is used for entering the phone numbers that allow free calls, e.g. the numbers that begin with the digits 0800. No charge impulse information is generated for these numbers. The notes above also apply to this list.

The third list contains numbers or prefixes that shall always see the calling party number when called (CLIP), even if this function is disabled (CLIR is enabled) for the calling channel. This allows to enable CLIP and return call handling for specific numbers (see 3.3.10).

3.3.7 Fax/Data

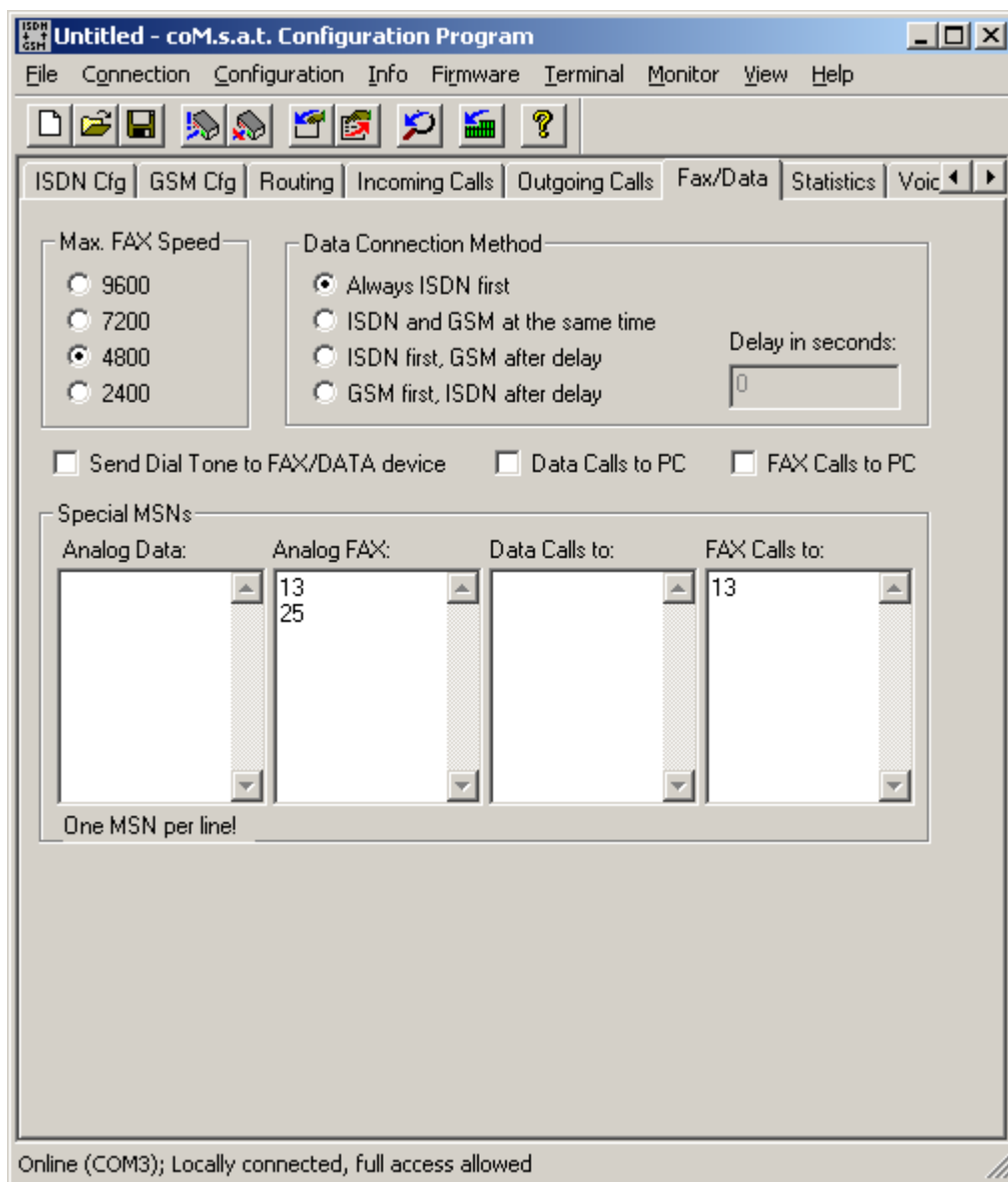

Figure 14: Fax/Data

This page allows the configuration of data and fax connections.

The option “**Max. FAX Speed**“ modifies the transmission speed negotiation of the two connected fax devices if they want to use a higher data rate than specified by this option, This concerns the fax transmission data rate, not the actual speed of the GSM connection. The maximum data rate of 9600 often causes problem within the GSM network. A reduction to 4800 baud is sufficient most of the time to avoid such problems.

An analogue data connection needs to establish two connections. First there is a connection between the internal modem of the **coM.sat** ISDN Plus and the local modem connected via ISDN and PBX. The second connection is from a GSM network internal modem to the remote modem. Therefore a connection from a local modem to a remote modem requires two analogue data connections that are established in a usually slightly different time.

Note: Data received on the first established connections is buffered until the second connection is also up and then transferred.

The settings of the field "**Data Connection Method**" allows to determine in which order and at what time the two connections shall be initiated. This allows, e.g., to adapt the connection setup time to the locally required time to complete a connection so that they are roughly established at the same time.

If "**Always ISDN first**" is activated, the connection to the local modem is established completely before the remote modem is called. This causes a long time difference between the two active connections, but it also prevents an unnecessary GSM call causing costs, if the local modem connection can't be established.

If "**ISDN and GSM at the same time**" is selected, the two connections are set up at the same time (after receiving dial information in case of calls to GSM).

The option "**ISDN first, GSM after delay**" causes a connection set up to the local modem immediately, while the GSM connection is set up after the configured delay.

On "**GSM first, ISDN after delay**", the GSM connection is initiated immediately, while the local modem connection is initiated after the configured delay.

Note: The optional fax/data module must be employed in the **coM.sat** ISDN Plus. Previous devices contained one modem, current devices (firmware version $\geq 6.0.0$) contain two modems and therefore allow two data calls or one data and one fax call at the same time, but not two fax calls.

The lists in the lower area of the page allow the configuration of MSNs associated with fax and data connections (one MSN per line). The lists "**Analog Data**" and "**Analog Fax**" must be filled with the MSNs of analogue modems and fax devices, respectively, in order to identify these kind of connections. The lists "**Data Calls to**" and "**FAX Calls to**" contain MSNs, that incoming data or fax calls shall be connected to. If more than one MSN is entered, these numbers will be called one by one until a device accepts the call (e.g. not busy).

If a local analogue modem or fax device calls, but its MSN is not configured as fax or data MSN, the call is treated as a voice call which will usually cause a failure of the connection since the analogue tones can not be transferred in the voice channel without loss. However, some PBXs also have a configuration of connected fax devices and insert a fax identification code in the call setup message so that the **coM.sat** ISDN Plus detects a fax call even if the MSN is not in the "**Analog Fax**" list.

It is also possible to send and receive data and fax on the serial interface of the **coM.sat** ISDN Plus. In this case, the connected PC must have suitable software for fax or data which is ready to receive incoming calls. To enable this, "**Data Calls to PC**" and/ or "**FAX Calls to PC**" must be enabled. Then the **coM.sat** ISDN Plus behaves like an analogue modem on its serial interface, i.e. incoming calls are reported with a "**RING**" indication. Following commands and data are directly transferred between PC and GSM module so that it behaves as a fax class 1 modem for the PC.

Outgoing fax and data connections are always possible via the serial interface without special configuration. If the dial command (ATD) is detected, this command is given to a free GSM module regarding the net access numbers, and this module is connected transparently to the PC, so that the PC again operates as if connected to a fax class 1 modem. If the PC sent other commands immediately before the dial command which are not processed by the **coM.sat** ISDN Plus itself, these commands are also sent to the GSM module before dialling. Further information on fax and data connections can be found in chapters 4.5 and 4.6

Note 1: The SIM cards used must support fax and data calls.

Note 2: If no MSNs are configured to send fax or data calls to, these kind of calls from GSM are rejected.

Note 3: If fax and/or data shall be exchanged with the use of a PC, but the PC software did not activate the serial interface and there are no MSNs configured to call in this case, these calls will be rejected.

Note 4: If a data or fax call comes from an MSN that is not configured in the appropriate list, the call proceeds as voice call. Due to the voice coding in the GSM network, this will either result in extremely low data rates or connection failures.

3.3.8 Statistics

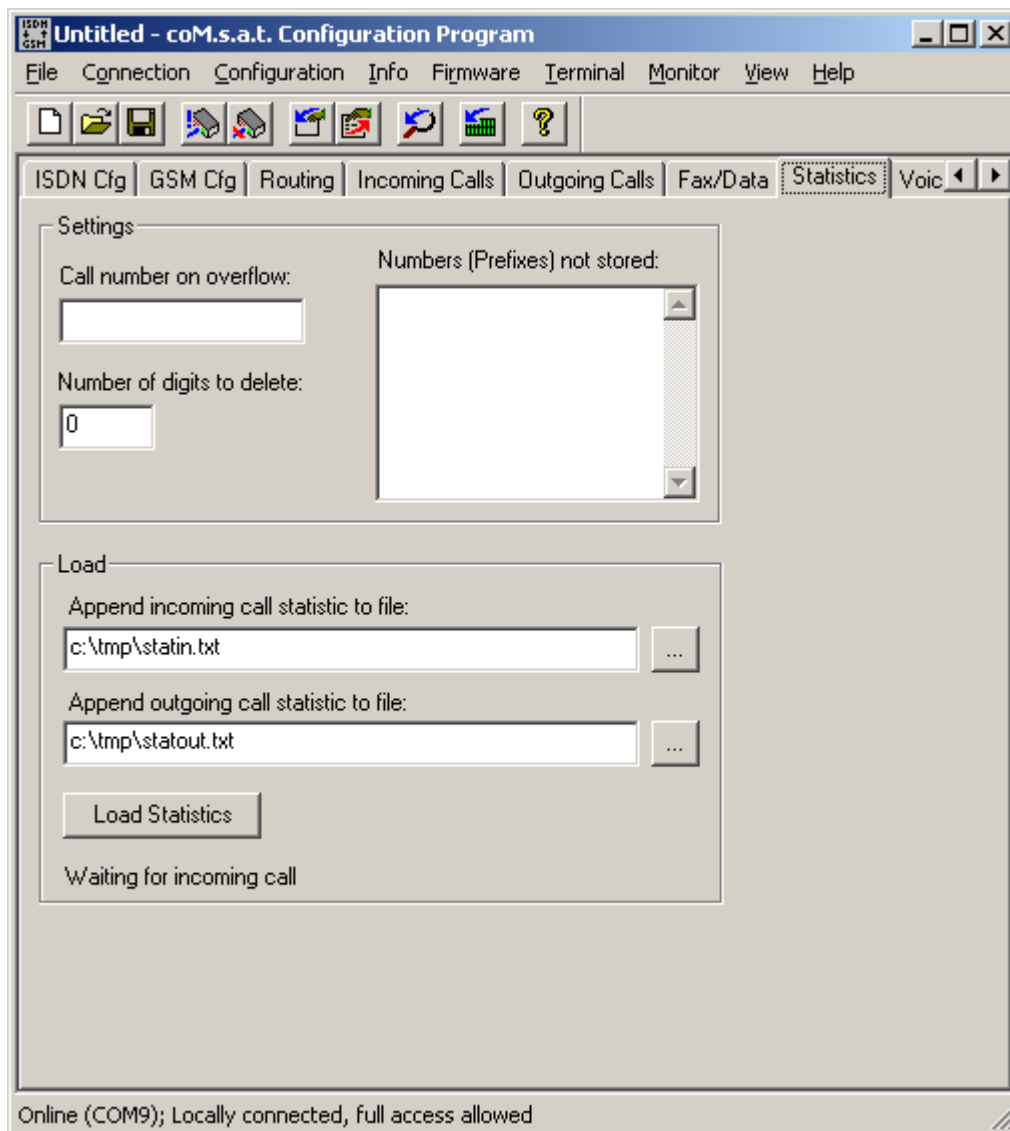

Figure 15: Statistics

The statistic functions are intended for the storing of call data. Incoming and outgoing calls are registered. The information is stored in two different files. Due to the limited memory space, call data is stored until the available memory is almost used up. When it becomes obvious that memory will shortly be full, a data call is set up to the pre-defined number which is set under "**Call number on overflow**". This must call a GSM modem (e.g. another **coM.sat** ISDN Plus in transparent mode, see 3.3.18) in a central office that is equipped with a SIM card allowing data transmission. There must be a PC running **coMsat.exe**, which is in contact with the GSM modem over a serial interface and which has the statistics page opened. This enables it to react on incoming calls (RING). In this case the call is accepted, the statistics read out and the call terminated again. The current action is displayed beneath the "**Load Statistics**"

button, e.g. "Waiting for incoming call".

The call data can be read out manually by clicking the "**Load Statistics**" button. The read-out data is stored on the PC in predefined files. New data is appended to existing files. Outgoing call data are written to the file set in the "**Append outgoing call statistic to file**" box. Incoming call data are written to the file set in the "**Append incoming call statistics to file**" box. In order to ensure protection of data security, two measures are implemented. On the one hand phone numbers and prefixes not to be stored at all can be defined in the list "**Numbers (Prefixes) not stored**". On the other hand the stored numbers can be truncated by a defined number of digits set in "**Number of digits to delete**".

The read-out data is stored in such a way as to easily process them with standard spread sheet applications such as Microsoft Excel® as follows:

Incoming: Calling number, Date, Time, Duration, Internal Number

Outgoing: Called number, Date, Time, Duration, Internal Number

The "Internal Number" represents the originating or terminating extension.

3.3.9 Voice

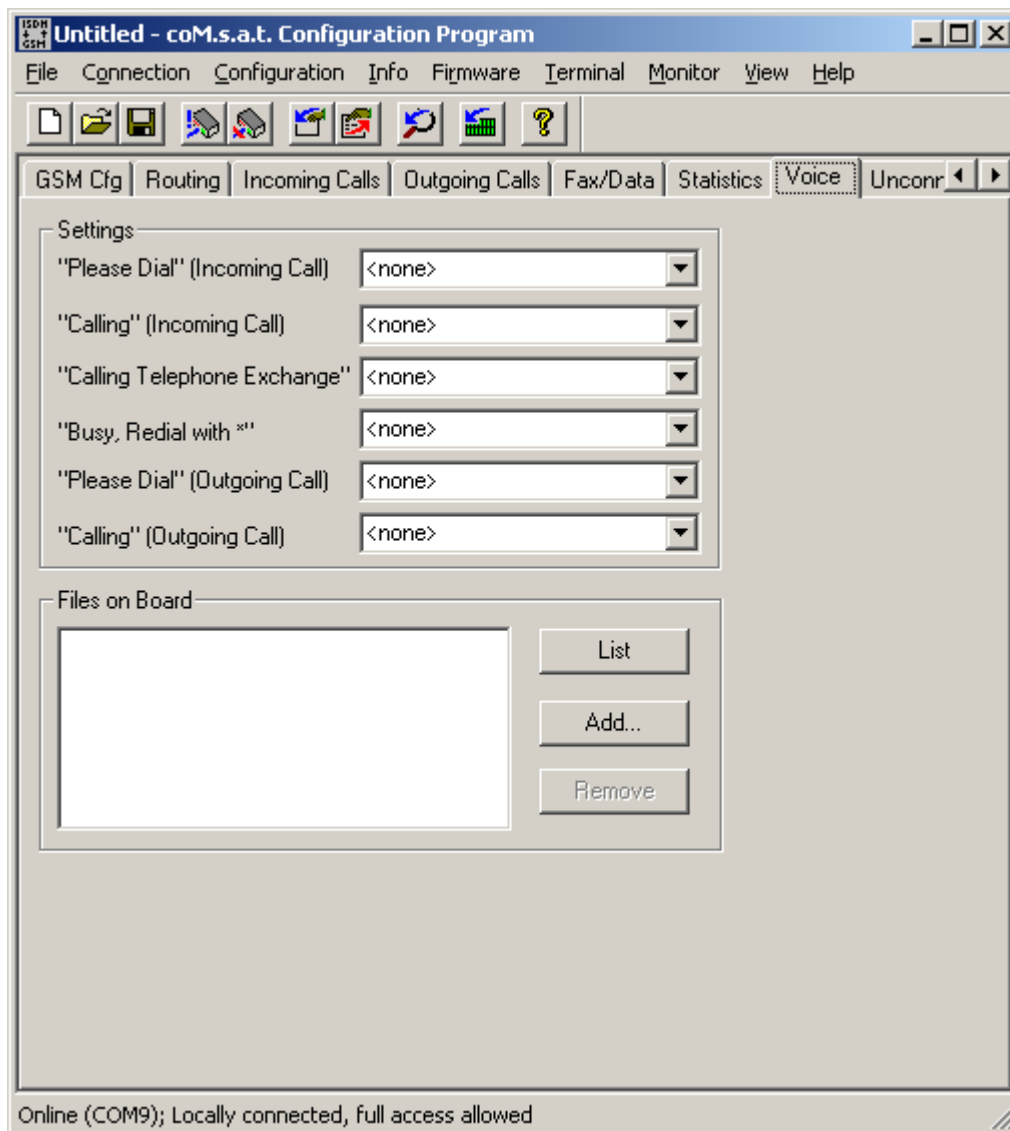

Figure 16: Voice

In certain operating situations voice announcements can be blended in to inform the user during call build-up or forwarding. 6 different announcements can be stored in the **coM.s.a.t ISDN Plus** memory. These messages are intended for the following situations:

1. On incoming calls, the caller can be informed to dial the extension number ("**Please dial (Incoming Call)**").
2. On incoming calls, the caller can be informed that the desired subscriber's extension is called ("**Calling (Incoming Call)**").
3. On incoming calls, the caller can be informed that the default number is called ("**Calling Telephone Exchange**").

4. On incoming calls, the caller can be informed that the desired subscriber's extension is busy and that he can dial again after '*' ("**Busy, redial with ***").
5. On outgoing calls, the caller can be informed that to dial ("**Please dial (Outgoing Call)**").
6. On outgoing calls, the caller can be informed that the desired destination is called ("**Calling (Outgoing Call)**").

Regarding all announcements, please note that these may altogether be no longer than 60 seconds due to the limited memory space. Furthermore these announcement .wav-files must be stored in the **CCITT A-Law format** with 8 bits and mono recording at 8000 samples per second. Wav-files with the announcements are assigned to the appropriate situations and/or functions by the input boxes.

The list box in the lower part of the tab displays the files loaded into the device. The display can be updated by clicking the "**List**" button. The "**Add**" button adds further files. The "**Remove**" button enables single files to be deleted. This button is only active if files have been loaded previously and a file is selected.

3.3.10 Unconnected Calls

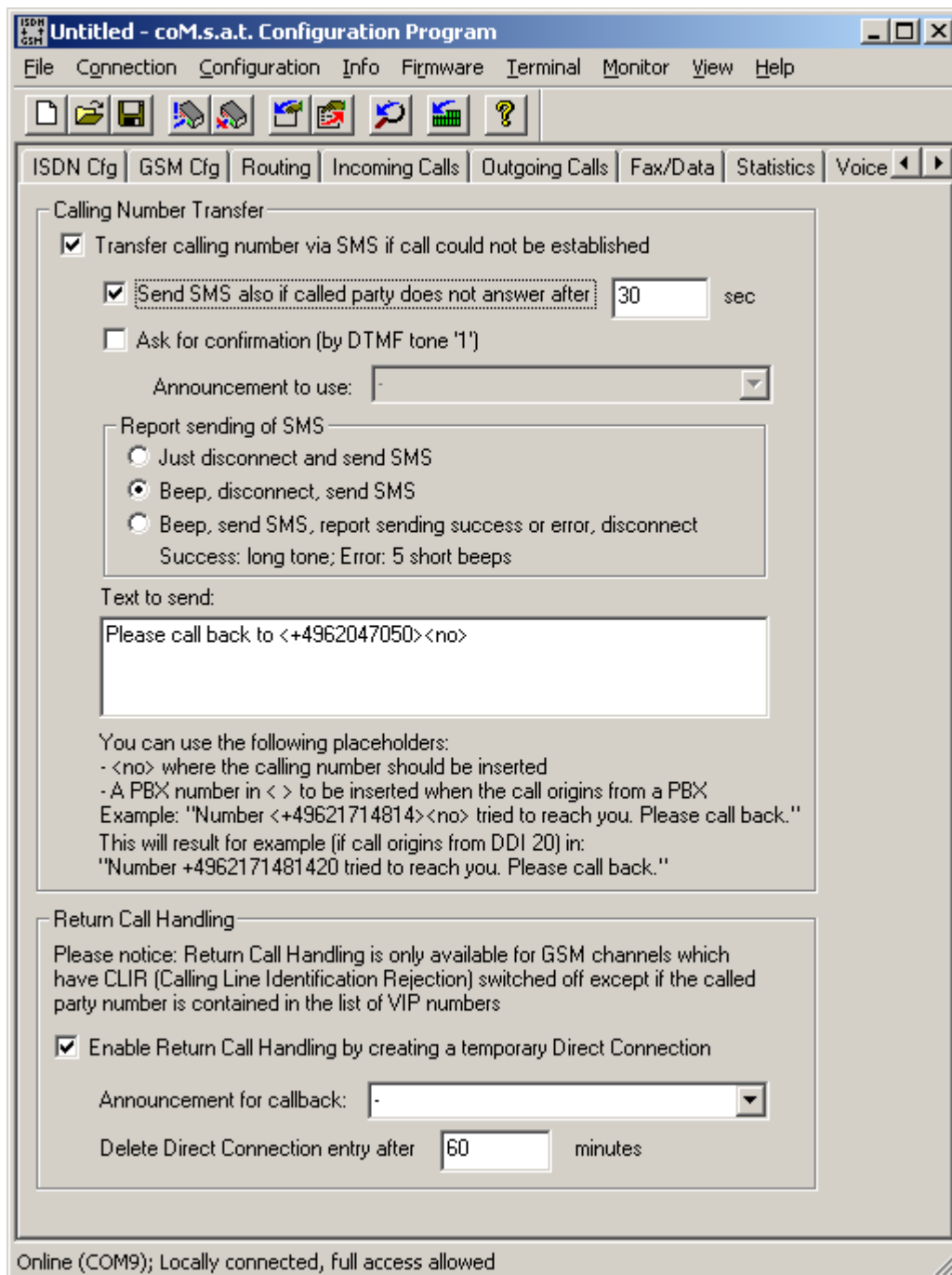

Figure 17: Unconnected calls

The settings on this page solve the following problem:

When using a GSM gateway the calling party number can not be transferred to the called party, but he sees the number of the SIM card of the gateway (if CLIR is switched off, else none at all).

On one side this is inconvenient for the called party because it can not decide whether to accept the call or not.

On the other side a problem occurs when the call is not accepted, or the called party is busy. In this case it is not possible for the calling party to wait for a return call, because the called party has no information about the calling party number.

It would be possible to transfer the number of the used GSM module so the called party could make a return call and be connected to the PBX. This is of little use because the caller has no information concerning the DDI from which he was called, so he could only be forwarded to the default number.

To overcome this problem, two strategies are possible, depending on whether the CLIR of the calling GSM channel of the gateway is activated or not.

The “**Calling Number Transfer**“ settings activate the sending of an SMS to the called user who could not be talked to. This SMS contains a text and additional information on the number to call back. This additional information has the following syntax and meaning:

<callback number><no>

callback number: The head number of the PBX

no: Extension number

Example:

The following text has been entered for the SMS:

“Please call back to <+4962047050><no>”

(Do not enter the quotation marks)

If the caller calls from extension 18, the called user gets the following SMS:

“Please call back to +496204705018”

The time after which an SMS is to be sent if the called party does not answer can be configured. If e.g. the called party does not answer within 30 seconds, the call is terminated and the SMS sent. If the called user rejects the call or is busy, this happens immediately.

The sending of the SMS can optionally be done only after confirmation by the caller, not automatically. To configure this, the option “**Ask for confirmation**“ must be activated. Then the SMS is only sent if the caller sends the DTMF tone of digit 1. Then it is additionally possible to configure an announcement that asks for the confirmation instead of only playing a tone.

In addition, confirmation tones can be sent to the caller depending on the setting of “**Report sending of SMS**“.

The “**Return Call Handling**“ settings control the processing of a callback of the user that was not reachable. When a call to a GSM party can not be established, the

gateway stores the called party number together with the calling party number (normally an extension of the PBX) in a list.

When a call comes in from GSM the gateway looks for the calling party number in this list. If an entry is found, the call will be directly connected to the stored extension. The duration that an entry should remain in this list can be configured with the option "**Delete direct connection entry after**". If there is no callback within this period, the entry in the list is deleted.

The user who calls back can optionally hear an announcement telling him that he is directly connected to a user who tried to call him. To achieve this, the option "**Announcement for callback**" must be set to a programmed announcement. If it is, the user calling back is connected immediately to play the announcement and therefore is charged the GSM fee immediately even if the called user does not answer the phone. If no announcement is set, the GSM call charging will start only if the called user accepts the call.

Every called party number can only be once in the list. A new call to this number overwrites an older entry.

If both options are activated, the Return Call Handling has precedence because it causes not costs. Only if this option can not work because CLIR is activated, the Calling Number Transfer procedure is invoked.

3.3.11 Diversion

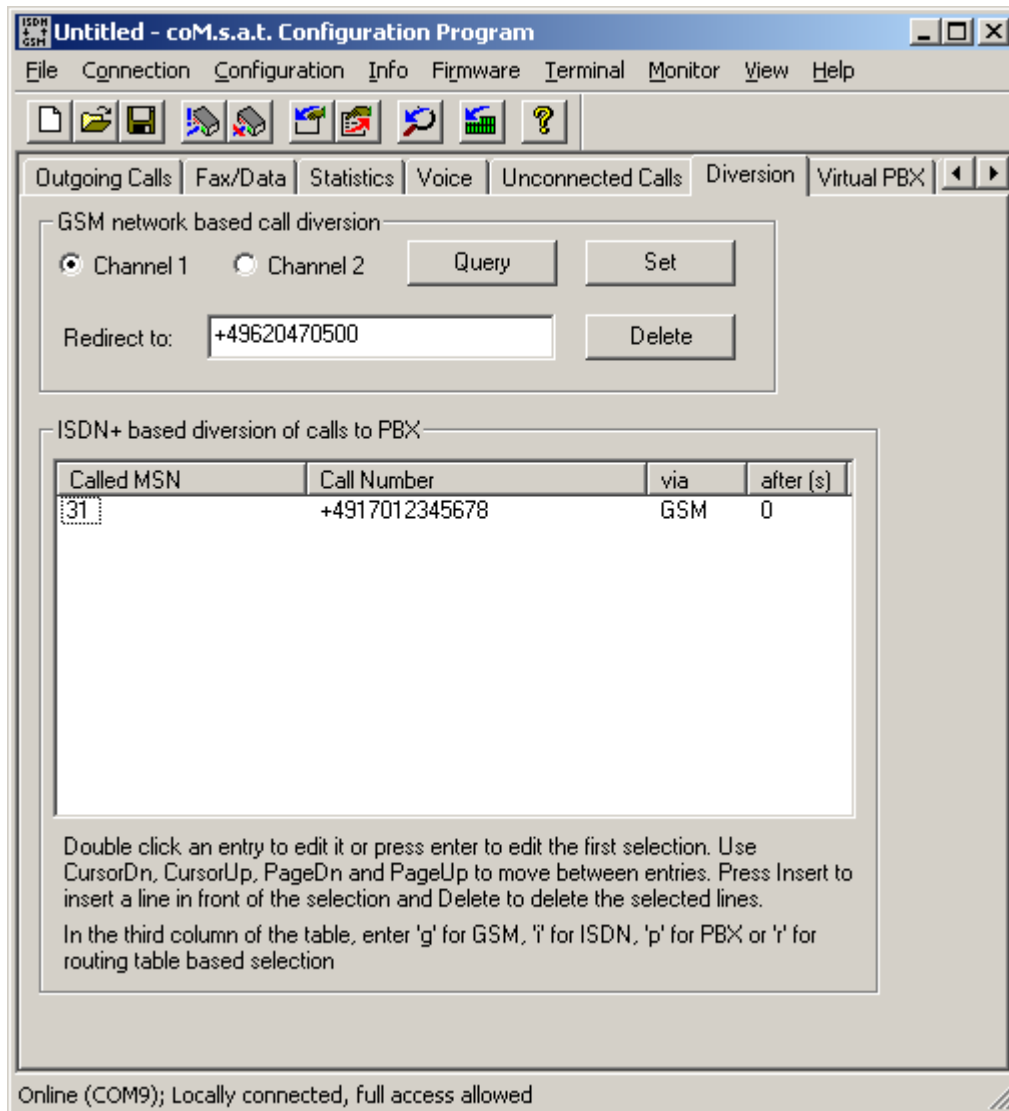

Figure 18: Diversion

On this page, two types of call diversion can be programmed: Call diversion inside the GSM network and call diversion inside the **coM.sat** ISDN Plus.

The call diversion inside the GSM network causes the network to call a different number if the dialled number is busy or unreachable. This kind of diversion allows e.g. if there is a diversion from channel 1 to channel 2 to always call channel 1. If that channel is already in use, channel 2 will be automatically called and the caller need not set up a second call manually.

First the channel to work with must be selected (select “**Channel 1**” or “**Channel 2**”). The button “**Query**” instructs the device to query the currently active call diversion

from the GSM network. This procedure needs a data exchange with the GSM network as all three functions so that it may take 20 seconds or more. As a result of the query, the number redirected to is shown in field **“Redirect to”** or a message reports that there is no diversion. To program a diversion, first enter the number that is to be redirected to and then push the button **“Set”**. About 20 seconds later, the positive or negative operation result is displayed. Pressing the button **“Delete”** causes the call diversion to be deleted.

The second possible call diversion by the **coM.sat** ISDN Plus offers the possibility to call a different number immediately or after timeout if a specific MSN is called. For each diversion, an entry must be programmed in the table that contains the called MSN, the number to redirect to, the route to be used and the duration of the alerting before redirecting. The MSN must be programmed without PBX number. The redirected call may use GSM, fixed network or PBX as destination or the destination can be determined by the routing table. This is programmed with the shortcuts **“g”**, **“i”**, **“p”** or **“r”**, which are automatically expanded in the table. The timeout may be set to 0 which means the call shall be redirected immediately. If the value is not 0, it determines how many seconds the original extension is alerted before the call is redirected.

It is possible to program multiple redirections for a single MSN. To do this, simply enter one line for each redirection all with the same MSN. These lines are processed from top to bottom, i.e. the first entry is used as first redirection. If that redirected number also does not accept the call, it is redirected to the number in the next entry. Keep in mind that in this case, a timeout of 0 (immediate redirection) may only be used for the first entry. Following redirections only make sense if they are alerted for some time before redirected again.

If a called number is busy and there is a diversion programmed, the redirection is immediately started after it is reported busy.

3.3.12 Virtual PBX

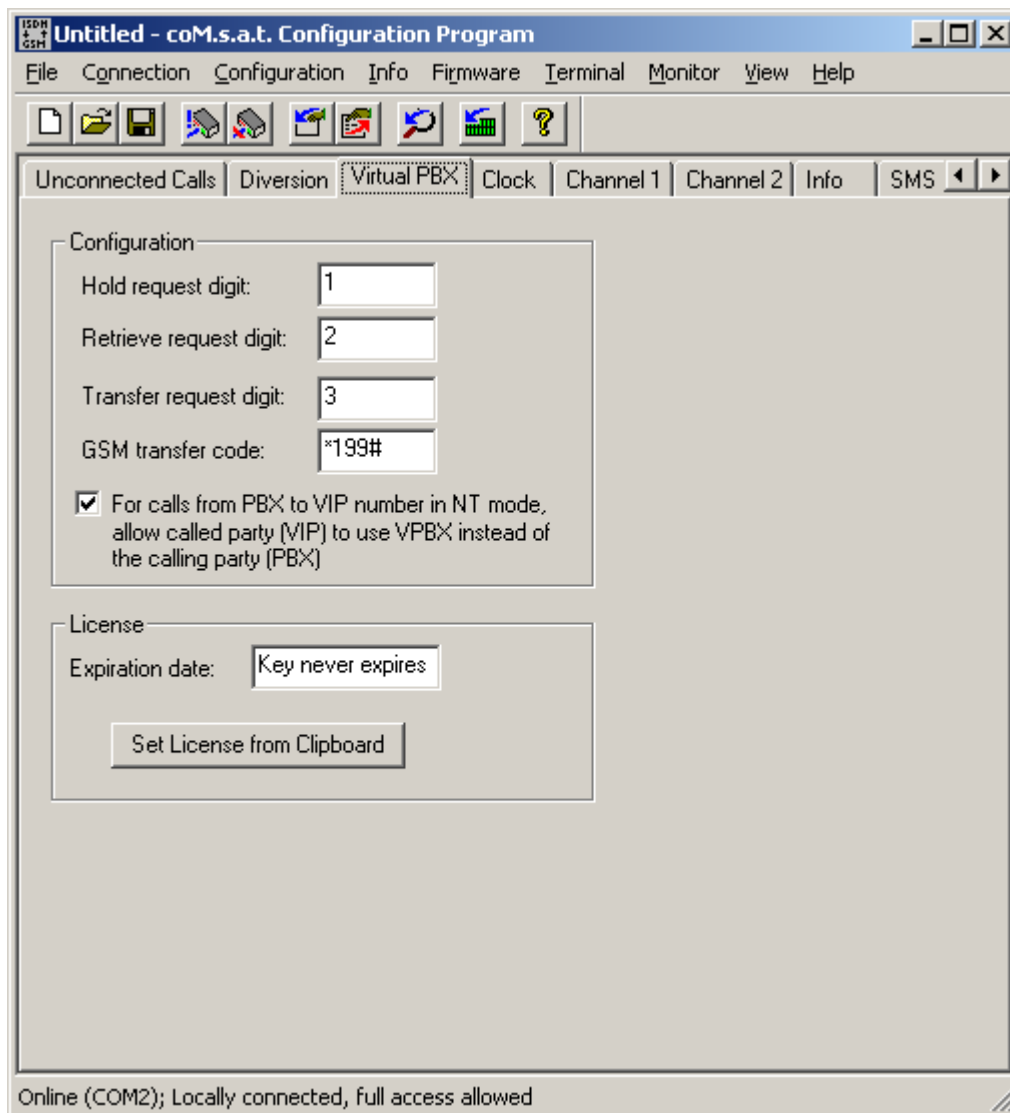

Figure 19: Virtual PBX

3.3.12.1 General Information

The virtual PBX features extend the gateway functionality by the supplementary services:

- call hold
- call retrieve and
- call transfer.

It can be used in combination with a dedicated PBX system or as a standalone solution. Unlike standard PBX applications the virtual PBX allows to configure GSM callers to be handled as internal callers (see also 3.3.3), so that also the GSM caller

can benefit from the supplementary services. Therefore the virtual PBX feature is also useful even if there is already a PBX available.

The supplementary services are invoked by dialling preconfigured digits/signs. Configuration and usage of these services is explained in detail in the chapter "Configuration".

At any time only one of the two connected users is able to invoke the virtual PBX feature:

- If an internal user (internal ISDN user or GSM user configured as VIP) calls an external user, the internal user is able to use the services.
- If two internal users are connected, only the calling user is able to invoke the services.

The second rule can be changed for calls from an internal ISDN user to a GSM VIP user in NT mode. If the last option in the configuration part of the dialog, „**For calls from PBX...**“, is activated, then the GSM VIP user would be able to use the VPBX in such call. This is useful if a PBX is connected to the **coM.sat** ISDN Plus which also implements the VPBX supplementary services. If it is not activated, which is the default setting, then the ISDN user can invoke the VPBX supplementary services. This is usually needed if no PBX is connected.

Please Note: If the device is configured in TE mode, all calls from ISDN are considered to be external calls.

3.3.12.2 Configuration

Three digits need to be specified which are used to invoke the call hold ("**Hold request digit**"), call retrieve ("**Retrieve request digit**") and call transfer service ("**Transfer request digit**"). All ten digits (0, 1, ...9) and the * or # signs are allowed. It is possible to configure multiple digits, so that an erroneous invoking of a virtual PBX function can be avoided. In this case, the desired function is activated if the configured digits are received in the order specified. The time between the dialling of the digits does not matter.

For transferring a call inside the GSM network, an additional setting, the transfer code, is needed. This is a string containing the digits that would be dialled manually on a cellular phone, followed by the send key (same as hook off). Usually these are three digits with "*" in front and '#' behind them, like "*199#". The network provider supplies this information.

If phones connected to the internal ISDN shall be able to call other internal ISDN phones, it is also necessary to add suitable routing information to the routing table. If e.g. internal phones have the phone numbers 10-29, an entry is needed that indicates local routing of numbers starting with "1" or "2" within the internal ISDN (PBX).

In router mode, a distinction of internal numbers and external numbers that may start with the same digits is needed. Therefore it is possible to distinguish these numbers by length. Therefore it is possible to set a routing for "1?,2?" to PBX. This entry has precedence if a called party number has exactly two digits.

3.3.12.3 *Call Hold*

During an active call, dialling the configured hold request digit(s) causes the audio connection to be disconnected. The held user gets a hold tone or announcement (march root tone / calling announcement for outgoing call) while the holding user hears a dial tone or announcement. The user who has invoked the hold function now is able to dial any other number, i.e. an internal or external one. This number is dialled using DTMF tones. During dialling, it is not possible to retrieve the held call, because the retrieve digit would be evaluated as called party number. Only if the new called number is complete and the call proceeds, it is possible to hold (again), retrieve or transfer a call.

When there is a mistake during dialling, terminate dialling by use of the '#' character and hold it again to repeat dialling. It is not necessary to retrieve the held call before holding it again, but it is of course possible (e.g. to notify the calling person).

If the held user is connected via GSM, the call is held using the GSM hold service. The GSM user will hear the network specific call held announcement. If the holding party calls another GSM number, this new call uses the same GSM channel that was used by the first call. This ensures that the second channel is still available for other calls and it also allows to connect the two GSM users inside the GSM network on call transfer without occupying any of the gateway's GSM channels.

3.3.12.4 *Call Retrieve*

A held call can be retrieved if the call to the third party is proceeding or connected. In this case, dialling the preconfigured retrieve request digit(s) causes the third party to be disconnected and the audio connection to the held user to be reestablished.

A connection to the newly called user is not necessary. If the held call is retrieved during alerting, the alerting stops.

3.3.12.5 *Call Transfer*

A held call can be transferred when the call to the third party is proceeding or connected. In this case, dialling the preconfigured transfer request digit(s) by the holding party causes the holding party to be disconnected and the audio connection between the held and the third user to be established. Transfer is also initiated if the holding party hangs up. A connection to the newly called user is not necessary. If the call is transferred during alerting, the alerting continues and the held caller still gets the call held tone.

If the held user and the third user are both GSM users, they get connected by the GSM network internally, and the gateway's GSM channel is available for other calls again.

Note: A GSM network internal call transfer is not offered by all network providers. If it is offered, the service invoke string is not identical for all networks. Therefore it has to be configured properly ("transfer code", see below).

3.3.12.6 *Licensing*

The usage of the virtual PBX feature is only possible with an individual license. To create a license, the IMEI of the first channel is needed. If the configuration tool reads the information (menu "Info", command "Query" or Ctrl-I), it automatically writes the first IMEI to the clipboard. This allows to copy it e.g. into an e-mail instead of typewriting it.

A license consists of three lines of text, e.g.

IMEI: 000543219876

Deadline: 1134798467 (17.12.2005)

Key: B19315A4DB40F39EF704F6A9B2BF2B8B16D93437EE0DDC81

This license can be obtained at coM.sat, e.g. by e-mail. The three lines can be marked in the text and copied to the clipboard (Ctrl-C). The configuration tool reads these lines from the clipboard if the command "**Set License from Clipboard**" is executed. The current license state is displayed above this command, e.g. "No license", "Key never expires" or the expiration date.

3.3.13 Clock

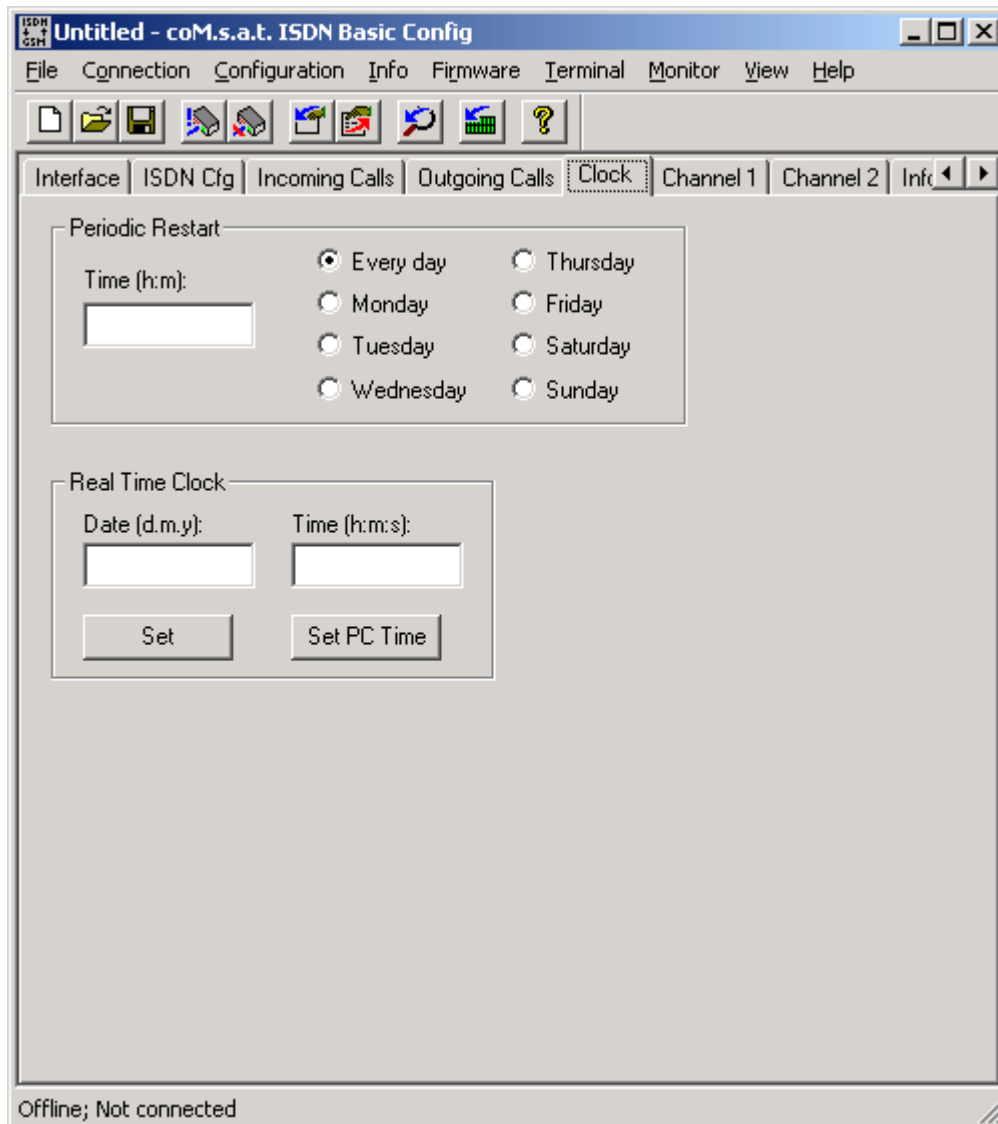

Figure 20: Clock

The **"Clock"** tab is used to set the device's real time clock. The respective time for the real time clock is then assigned to the entries in the trace memory to be able to follow the timing of the events entered there.

The current time is set by entering the date in **"dd.mm.yy"** format in the **"Date"** box and the time in **"hh:mm:ss"** format in the **"Time"** box. The time is updated by clicking on the **"Set"** button.

If the button **"Set PC Time"** is used, the current time is fetched from the PC's clock and transferred to the ISDN Plus. This function makes it a lot easier to set the current time if the PC time is correct.

With the menu “**Periodic Restart**“ there is a possibility to restart the unit on a certain time and day. A periodical restart could have more stability in some difficult installations or locations.

3.3.14 Channel 1/2

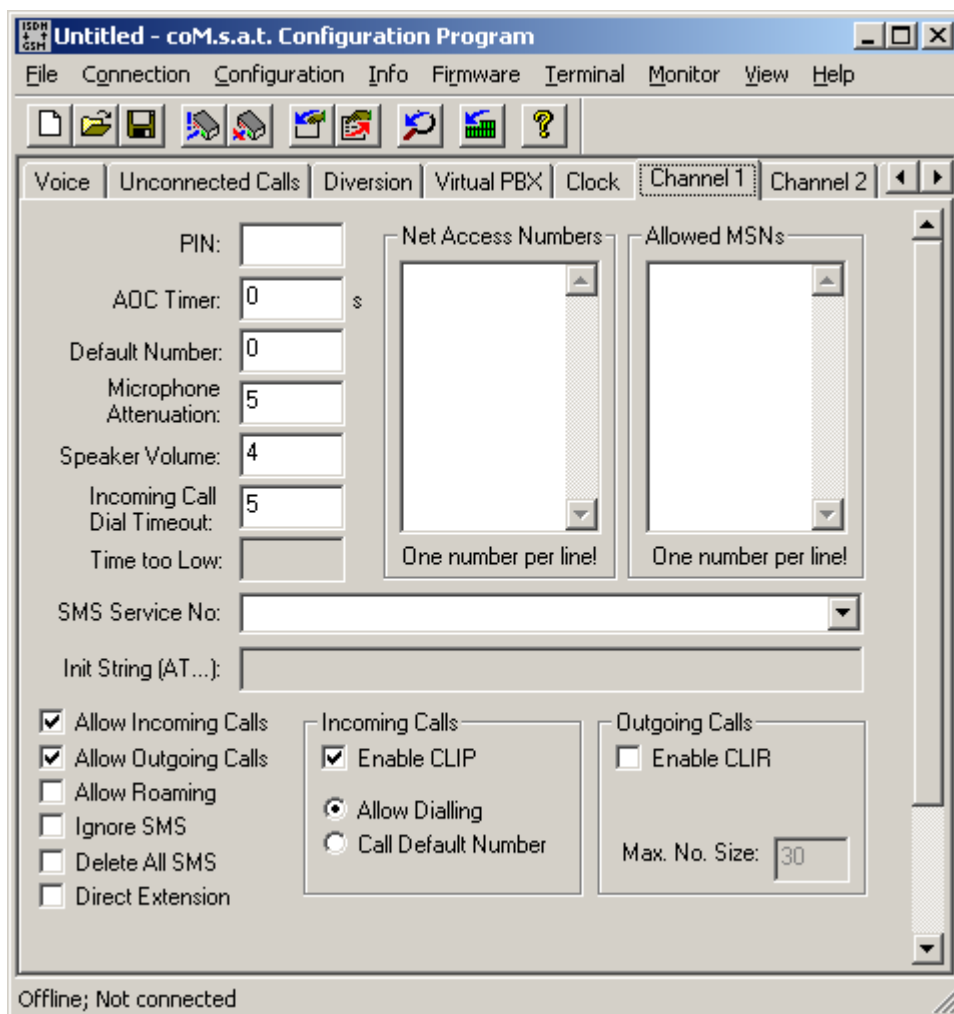

Figure 21: Channel 1/2

The card for the specific entries for channel 1 (same for channel 2) is used for entering the necessary details for the channel.

The SIM card “PIN” must be entered first. This entry is mandatory if entry of a PIN is prescribed for the SIM card used. In case the SIM cards used don't require such an entry, the input box remains blank.

If the GSM network cannot provide real charge information, artificial charge information (phase) is produced by the “AOC timer”. The AOC timer can be adjusted between 0 and 240 seconds.

The default number is the number of the extension that is called for incoming calls if “Call Default Number” has been selected. This number is also called if a caller does not dial anything.

The sound volume of the microphone and handset for the GSM channel can also be adjusted using this card if the preset level is insufficient. The preset values are 5 for

“**Microphone Attenuation**“ and 4 for “**Speaker Volume**“. Both values can be altered between 0 - 7, whereby lower values represent lower volume and higher values higher volume.

The time during which a consecutive number can be dialled is also configurable. The time span is pre-set to 5 seconds. This should suffice for most applications, but can be changed in the “**Incoming Call Dial Timeout**“ input box if necessary.

If prepaid SIM cards are used and their credit is set with the command “Set Prepaid Time“ in menu “Info“ (see 3.3.15), a threshold can be set in the field “**Time too Low**“. If the credit falls below this threshold, the channel will not be used anymore. In addition, an SMS can be sent (see 3.3.3).

Furthermore, the number of the “**SMS service centre**“ must be entered on this card, which is provided by the respective network provider whose SIM cards are used. The respective SMS centre can be selected from a list. This list is read in from the “sms.txt“ text file. If one of the numbers given has changed or a new number is to be added or should the numbers of the network provider outside of the country in which the TA is installed no longer be visible, the corresponding amendments can be made by changing the text file. Of course it is also possible to enter any number instead of selecting one of the list entries.

An “**Init String**“ is usually not needed. In some cases it may be useful to send an additional command to the GSM modules built into the device not given by the firmware of the device. Such an additional command can be entered in this field.

The network access numbers can be defined in a list box. This means that the dialling codes of the network providers that can be used for the calls are entered here. The numbers are entered as follows:

0170

0171

if e.g. only these two T-Mobile numbers are to be used.

Only one dialling code can be entered in each row.

Note: It is recommended to only make entries if restrictions are actually to be made. Otherwise it is advisable to leave this list box empty. In a further list box the numbers of those extensions that may access this GSM channel are set.

Furthermore, the incoming and outgoing calls are also configured here. You first define whether incoming and outgoing calls are allowed, then whether “**Roaming**“ (booking into networks abroad) is allowed. To do this, the corresponding option box next to the relevant text is clicked on.

The option “**Ignore SMS**“ determines the reaction to incoming SMS. In areas, in which many SMS are dispatched for advertising purposes and with devices with a lot of traffic (where reading and deletion of SMS can be a nuisance) it is recommended not to react to SMS. If the option is activated, then SMS are not retrieved from the GSM module. In this case remote maintenance by SMS is no longer possible!

The option “**Direct Extension**” enables a special function of specific GSM networks, e.g. the spanish Telefonica GSM network. In this mode, all numbers called via GSM get a ‘#’ and the calling MSN appended. This allows the called user to see which extension tries to call him. If a call from GSM comes in which has a ‘#’ followed by an MSN in the calling party number information, the gateway directly calls this MSN.

You can also set whether the phone number of the incoming call (CLIP) is to be transferred to the extension (“**Enable CLIP**”). Also whether consecutive dialling is permitted or whether the incoming call is transferred to a preset extension, the number of which has been entered under “**Default Number**” (see above). If consecutive dialling has been allowed, it is possible to dial another extension during the first 5 seconds (or whatever time has been set) after a connection has been established.

If outgoing calls are allowed, you can select whether the caller number is to be transmitted or not (“**Enable CLIR**”). In addition, the maximum length of a number dialled to GSM can be configured in field “**Max. No. Size**”. This is important if the option “**Direct Extension**” is enabled. In this mode, the called number’s length increases by the length of the calling MSN (see above). This increase of length may cause a number to exceed the limit of the GSM network, therefore the MSN is only appended if the resulting length is below or equal to the value configured here.

Note: If “**Allow Incoming Calls**” and “**Allow Outgoing Calls**” are deactivated, the channel is blocked for GSM calls.

If the “**Call Default Number**” option box is activated, the “**Default Number**” given above is dialled directly.

3.3.15 Info

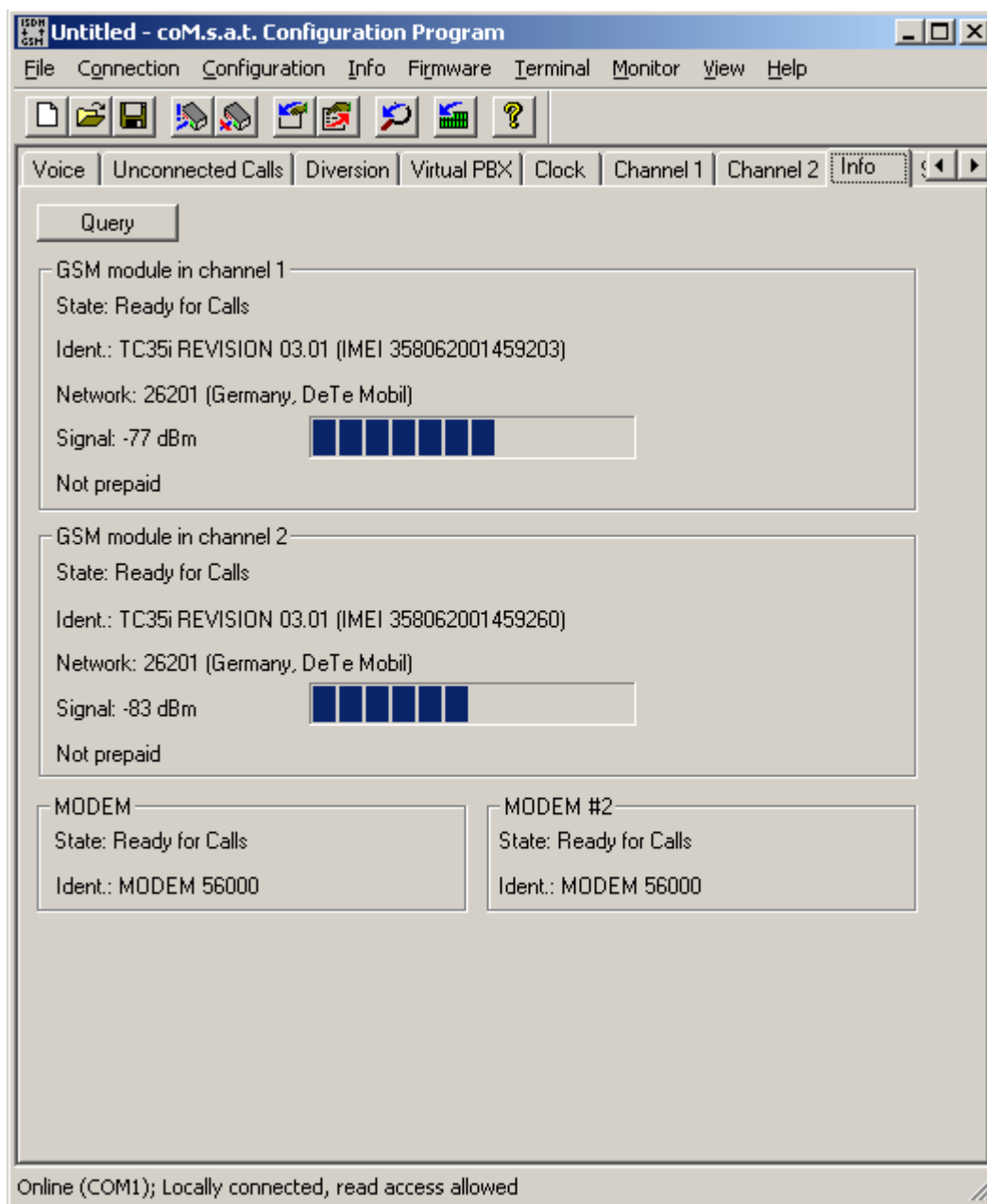

Figure 22: Module information

The state of the GSM modules which have been installed in the device are queried via the "Info" card file. The GSM modules' current state, firmware revision, as well as the current field strength of the antennas used at the installation site are reported. The currently available credit of prepaid SIM cards is also displayed. The MODEM modules' current state and identification strings are also reported. Since there are devices with only one GSM channel and/or no or only one MODEM, some of the fields may remain empty.

The data is updated after selecting Query in the Info menu on the menu bar. Alternatively, you can use the following keyboard shortcuts:

<ALT> <I>
and
<Q>.

The above information can be read out and shown in text form by invoking "**In Terminal**" in menu "**Info**". Or the AT-command at\$i can be entered directly into the terminal window available in the "**Terminal**" tab. The module information is then presented in the terminal window as shown in the following figure:

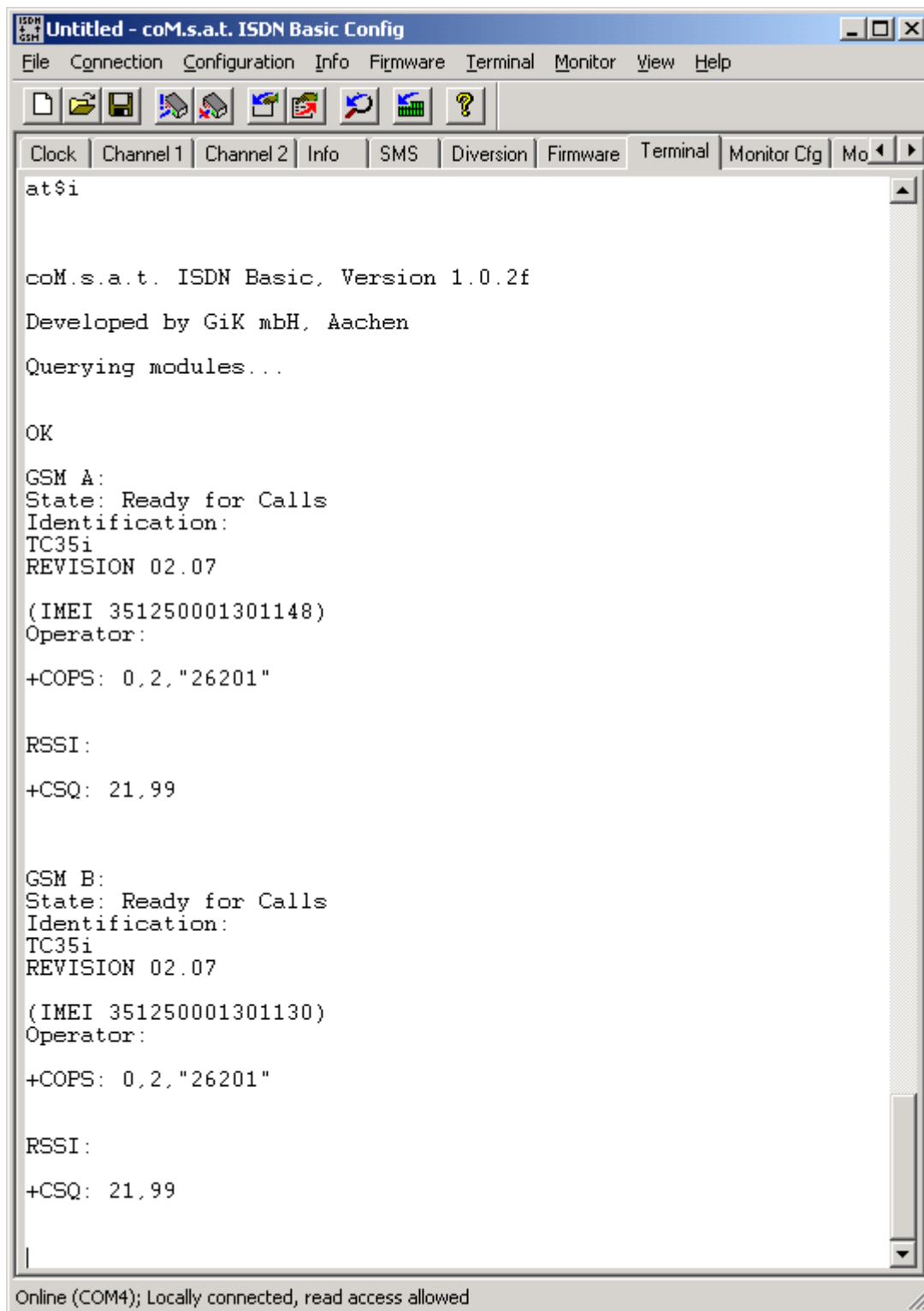

Figure 23: Module information in the terminal window

The menu "Info" also contains the command "Unlock SIM card". This function is needed if a SIM card is locked because of a wrong PIN. The following dialog opens:

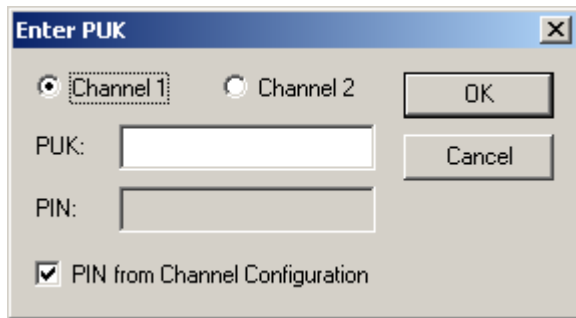

Figure 24: Unlock SIM card

The locked channel has to be selected and the PUK of the locked SIM card must be entered. The new PIN may be taken from the current configuration or entered manually. If “OK” is selected, the card gets unlocked and the result is reported. If it worked, the channel should log into the network.

Another command, “Set Prepaid Time“, is used to set the credit of the channels. It uses the following dialog:

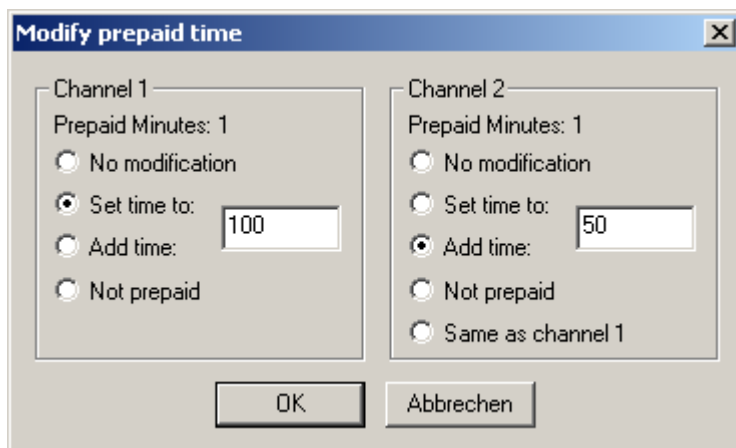
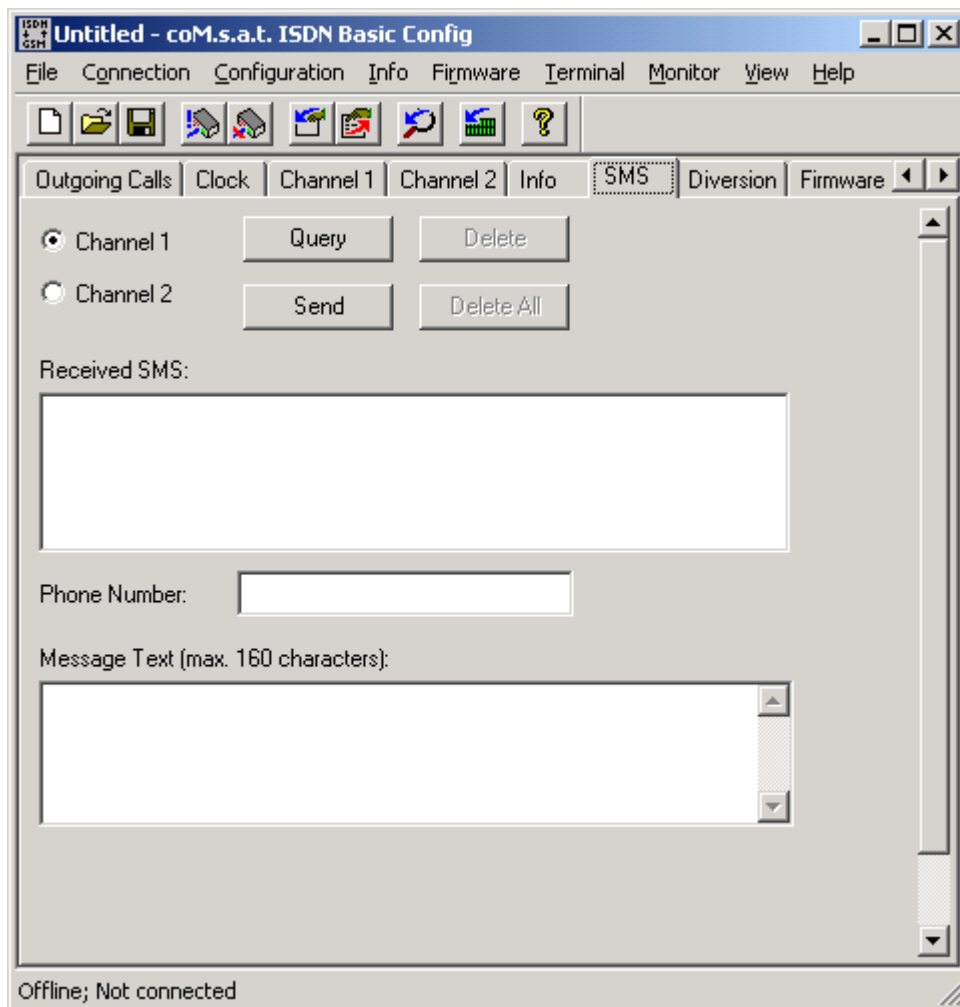

Figure 25: Set prepaid credit

Both channels allow the following choice:

- “**No modification**“: No change to the credit of this channel
- “**Set time to: ...**“: Sets the value entered in the edit field, i.e. the current value is overwritten
- “**Add time: ...**“: Adds the value to the current credit
- “**Not prepaid**“: Switches the prepaid function off

If both channels are modified identically, the desired modification can be entered for channel 1 and the option “**Same as channel 1**“ can be selected for channel 2.

3.3.16 SMS**Figure 26: SMS**

SMS messages can also be sent and received by the **coM.sat** ISDN Plus. This is achieved via the SMS card. First the channel via which the SMS messages are to be transmitted is defined in this card. The messages received are also administrated within this card. Two boxes are available for this; one for messages received and one for the message text. The telephone number of the SMS recipient is also entered in the card. SMS are transferred to and from the central office via the “**Query**” and “**Send**” buttons.

Note: SMS messages have a maximum length of 160 characters

Note: In order to be able to send SMS, the “**SMS Service Centre Number**” must be set in the “**Channel1/2**” tab.

The “**Delete**” and “**Delete All**” buttons are used to delete individual messages or all

the messages in the “**Received SMS**” box.

3.3.16.1 *Receive SMS*

To receive SMS messages, first select the reception channel and then click on the “**Query**” button. SMS messages that in the meantime have been stored on the SIM card for this recipient are now called up and shown in the “**Received SMS**” list. However, only the date received and the phone number of the sender are shown in this box. The content of an SMS is displayed if an SMS is selected using the mouse pointer. The message text then appears in the box below, the phone number of the sender is displayed in the “**Phone Number**” box.

The following property must be noted for the receipt of SMS messages. As the received SMS messages are stored on the SIM card, the available memory is limited. However, to ensure access to the device via remote servicing, the oldest message is always deleted (if “**Ignore SMS**” is deactivated) to ensure that sufficient memory space is available for a new incoming message. The precise remote servicing sequence is described in the Remote Servicing chapter.

3.3.16.2 *Send SMS*

If an SMS message is to be sent, first select the channel and then enter the message text in the “**Message Text**” box, whereby the message must not contain more than 160 characters. To send the message, enter the number of the recipient in the “**Phone Number**” box and then press the “**Send**” button. The message is then sent.

3.3.17 Firmware

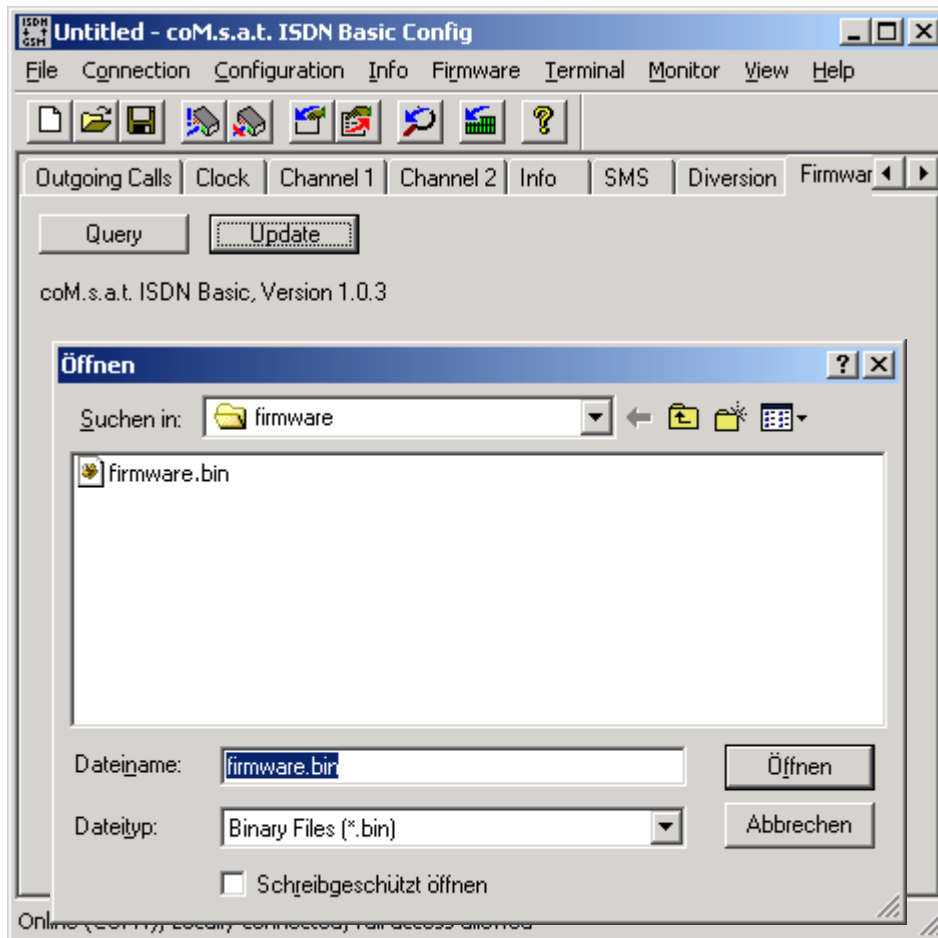

Figure 27: Firmware Update

The current version of the firmware used in **coM.sat** ISDN Plus is displayed in the “**Firmware**” card, after a query has been made via the “**Query**” button on the card or the “**Query**” entry in the “**Firmware**” menu of the menu bar. Alternatively, the keyboard shortcuts

<ALT><r>
and
<Q>

can be used.

A new version of the firmware can be transferred to the device via the data link with the aid of the **coMsat.exe** application. To do this, first select “**Firmware**” in the menu bar and “**Update**” from the menu. The usual Windows dialog for opening files is displayed. Select the file that is to be transferred to the **coM.sat** ISDN Plus. The transfer begins after clicking on the “**Open**” button.

Attention: The file to be loaded is "Firmware.bin", which is a binary file. To avoid malfunctions, only files approved by **coM.sat** should be loaded into the device.

In case of a power failure during reprogramming of the device or any other event that invalidates the program storage of the ISDN Plus, there is another tool that can program a new firmware even if the device is inoperable. The fload program located in the firmware directory is a command line based tool for programming the ISDN Plus. The fw_upd.bat batch file calls this program. Before using it, verify that it uses the correct COM port in the command line of fload. Then keep the reset button of the ISDN Plus pressed until the power LED is switched off for a moment. Release the reset button and run the fw_upd batch file. The firmware will be updated and after completion, the device must be reset again.

If the firmware shall be restarted, this can be done with the command "**Reset**" in the "**Firmware**" menu. This issues the command AT\$R to the device. This command can also be entered manually in the terminal. It requires a log in.

3.3.18 Terminal

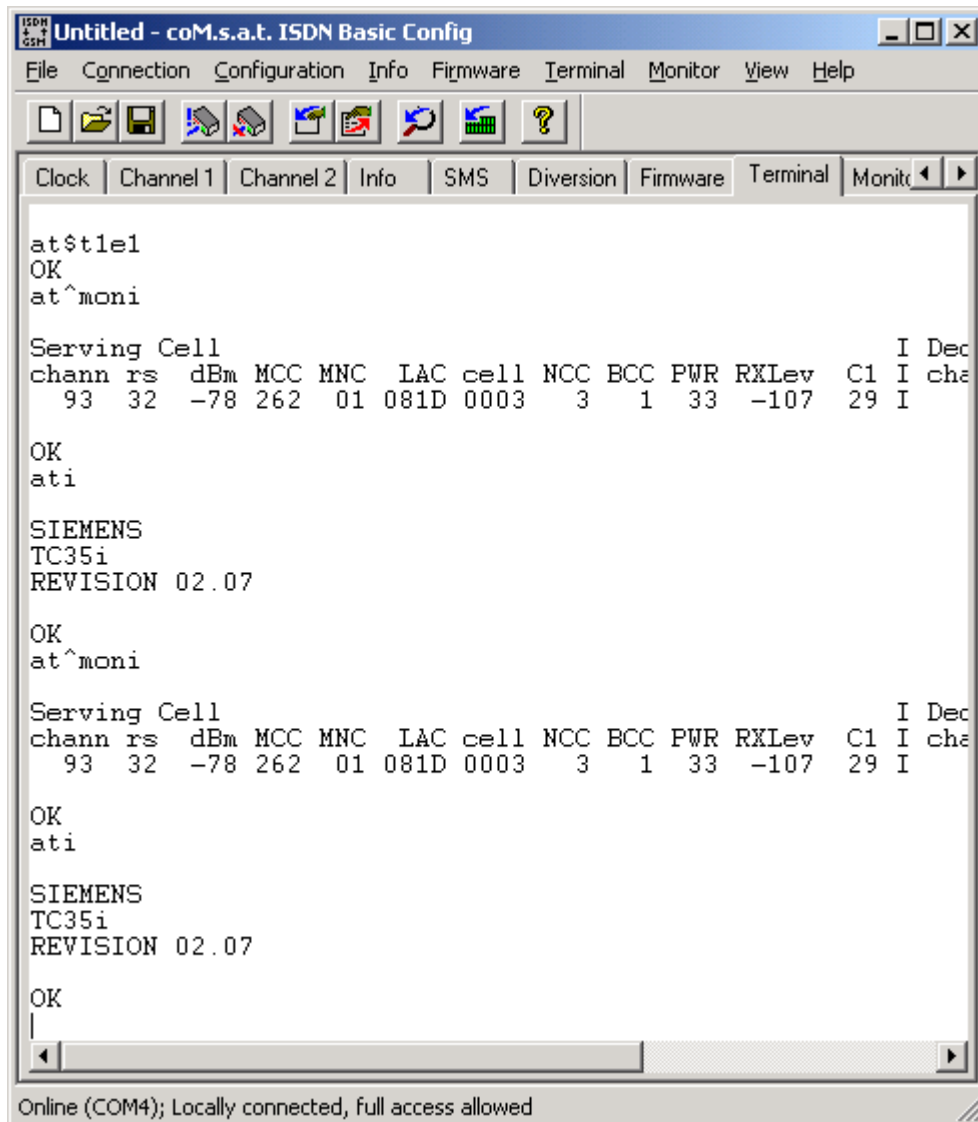

Figure 28: Terminal

The “**Terminal**” card acts like a terminal program. It can be used to track actions carried out by the **coM.sat ISDN Plus** in which a corresponding text is issued via the interface on the operations carried out by the TA. However, it is also possible to directly access the GSM module and to transfer commands to it. First the menu item “**Terminal**” is selected in the menu bar and then the entry “**Transparent Channel 1**” (or “**Transparent Channel 2**”) is selected in the menu that opens. The so-called AT commands, which are defined for the GSM module can then be used for the access. After completing the direct access to the GSM module, the transparent mode must be switched off again.

The protocol displayed in the terminal window can be used to analyse discrepancies. It can be saved for this purpose. However, it can also be deleted to record a protocol from a certain time onwards only. The protocol is saved or deleted by calling up the corresponding menu entry, “**Save**” or “**Clear**” in the “**Terminal**” menu on the menu bar.

3.3.19 Monitor Configuration

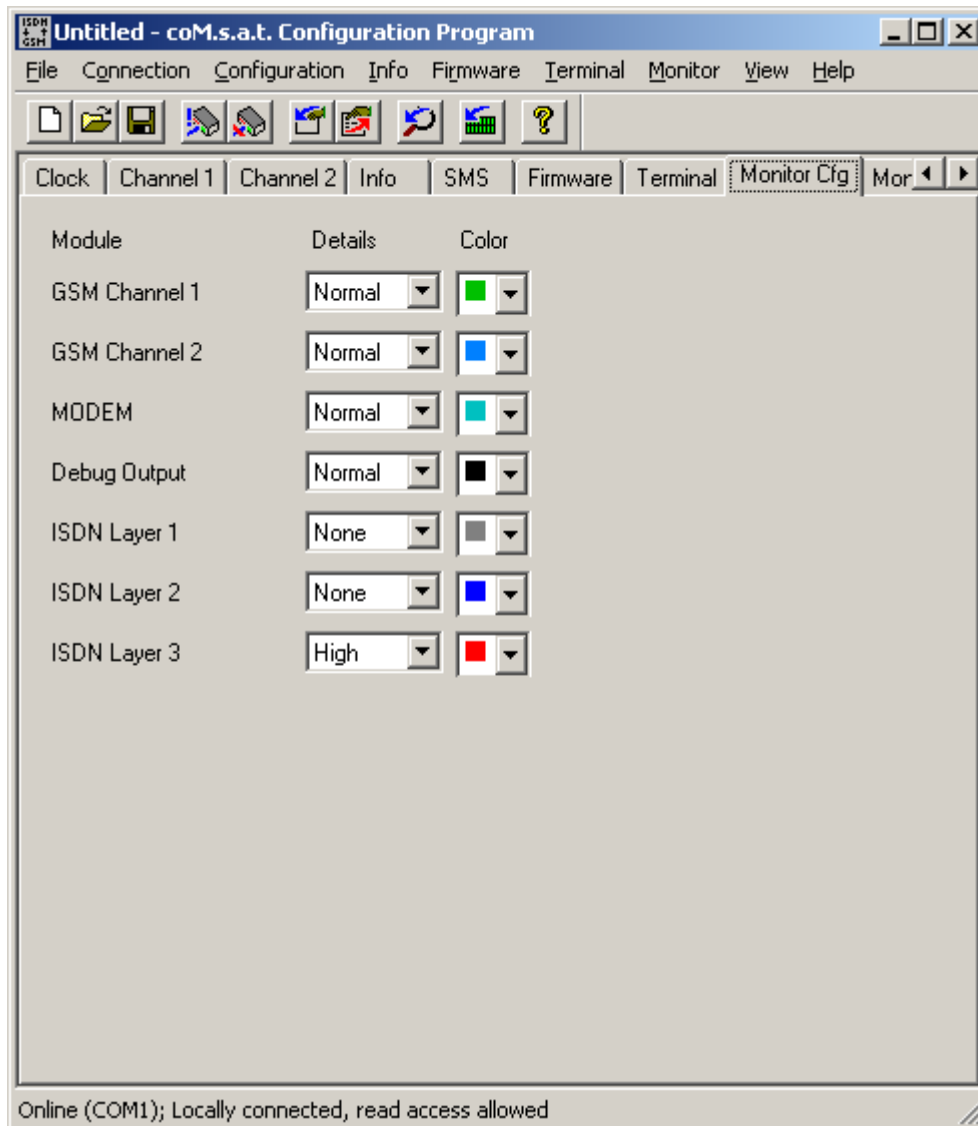

Figure 29: Monitor Configuration

The colour and content of the traces displayed via the “**Monitor**” tab are configured in the “**Monitor Configuration**” card. In this way, the clarity of the presentation can be individually adjusted. The configuration can be used to hide information that is not important at present from the trace. However, it continues to be available for calling up and can be unhidden as needed.

Various details and colours can be selected for

GSM Channel 1

GSM Channel 2

MODEM

Debug Output

ISDN Layer 1

ISDN Layer 2

ISDN Layer 3

For devices containing two internal modems, the second modem is displayed in a slightly modified color.

In case of routing configuration (both ISDN ports in use), the messages on the port to the ISDN network are shown in a slightly different color than those to the PBX.

3.3.20 Monitor

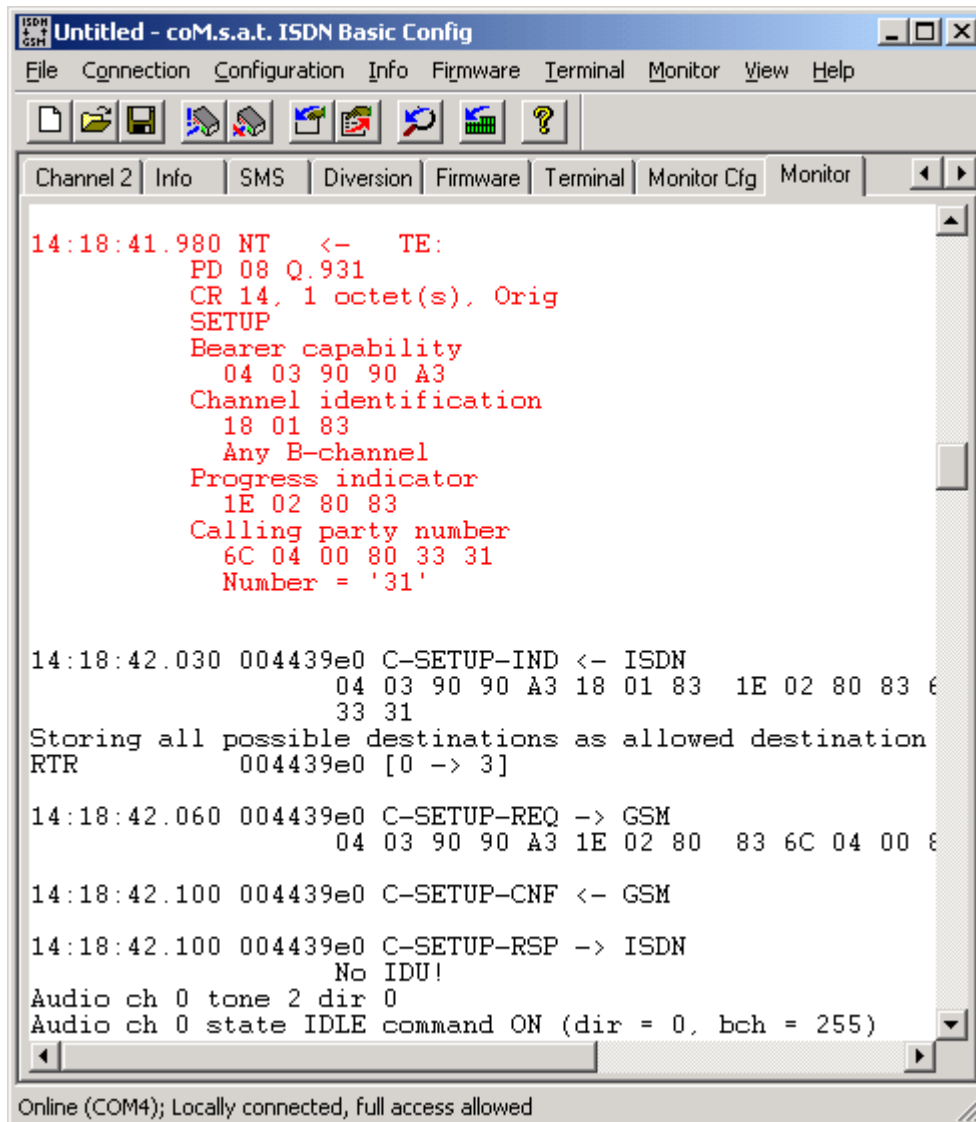

Figure 30: Trace recording

The activities on the S0 connection and between the **ISDN Plus** and the GSM modules are displayed on the “**Monitor**” tab, i.e. a “trace” of the D-channel protocol and the commands to the GSM modules as well as their responses are recorded. This data protocol is used both for in situ analysis when it is viewed in the monitor window as well as for analysis in another environment by saving it together with the configuration in a “*.cdc” file and opening this file with the **coMsat.exe** application on another computer. The ASCII save functionality is only available for using search and clipboard functions.

The information in the monitor protocol can be displayed in different colours for improved clarity. The colours for the various data and command paths are set in the **"Monitor Configuration"** card. Figure 30 shows an example of a "Trace".

Should certain installations induce the need for questions to the manufacturer, then the configuration, firmware version and module state should also be loaded besides the trace and stored together in a file and sent to the hotline of the manufacturer (Menu: File / Save as: <Expressive File Name>.cdc).

The **"Monitor"** entry menu provides options on what to do with the trace memory of the **coM.sat** ISDN Plus. It can be read out (Menu: **"Monitor"** / **"Load"**), the displayed trace can be stored in an ASCII file (Menu: **"Monitor"** / **"Save ASCII"**) or the displayed trace (not the trace memory in the ISDN Plus!) can be deleted (Menu: **"Monitor"** / **"Clear"**). The trace memory in the device occupies a defined memory area which cannot be increased. Thus, an exact storage duration cannot be given. It depends on the quantity of calls that are passed via the TA. The larger the number of calls the shorter the recording duration and vice versa. The recording duration can therefore range between a few minutes and approx. 1 hour. If such a trace is to be used for analysis, one should first be certain that the event actually occurred within the recording period. Otherwise, you should try to repeat the recording to "catch" the event. If an error can only be detected long after the event happened that caused the problem, it is necessary to load the trace periodically. This enables to "catch" the event even if it is hours ago. This function is described in chapter 3.3.1.

3.3.21 Additional information

The **"File"** menu lists the **"New"**, **"Open"**, **"Save"** and **"Save As"** menu items usually available under Windows. These are used by the standard Windows conventions and do not require any further explanation. As usual in Windows, the last 4 active configurations are listed in order (most recent first). The program can be quit by selecting the last menu entry **"Exit"**.

The menu item **"Monitor"** and the subsequent entry **"Load"** can be used to transfer current data from the **coM.sat** ISDN Plus for analysis. This data can be displayed via the **"Monitor"** tab and can be saved as an ASCII or a ".cdc" file. Further information on this is given in the **"Monitor"** and **"Monitor Configuration"** chapters.

The **"Toolbar"** can be selected via the **"View"** menu item and is positioned beneath the menu bar and by selecting the **"Status Bar"** the status bar below the main window is hidden or revealed. Furthermore, individual cards can also be called up via **"View"**.

The **"Help"** menu item is available to query the current version of the **coMsat.exe** application.

3.3.22 Vendor functions

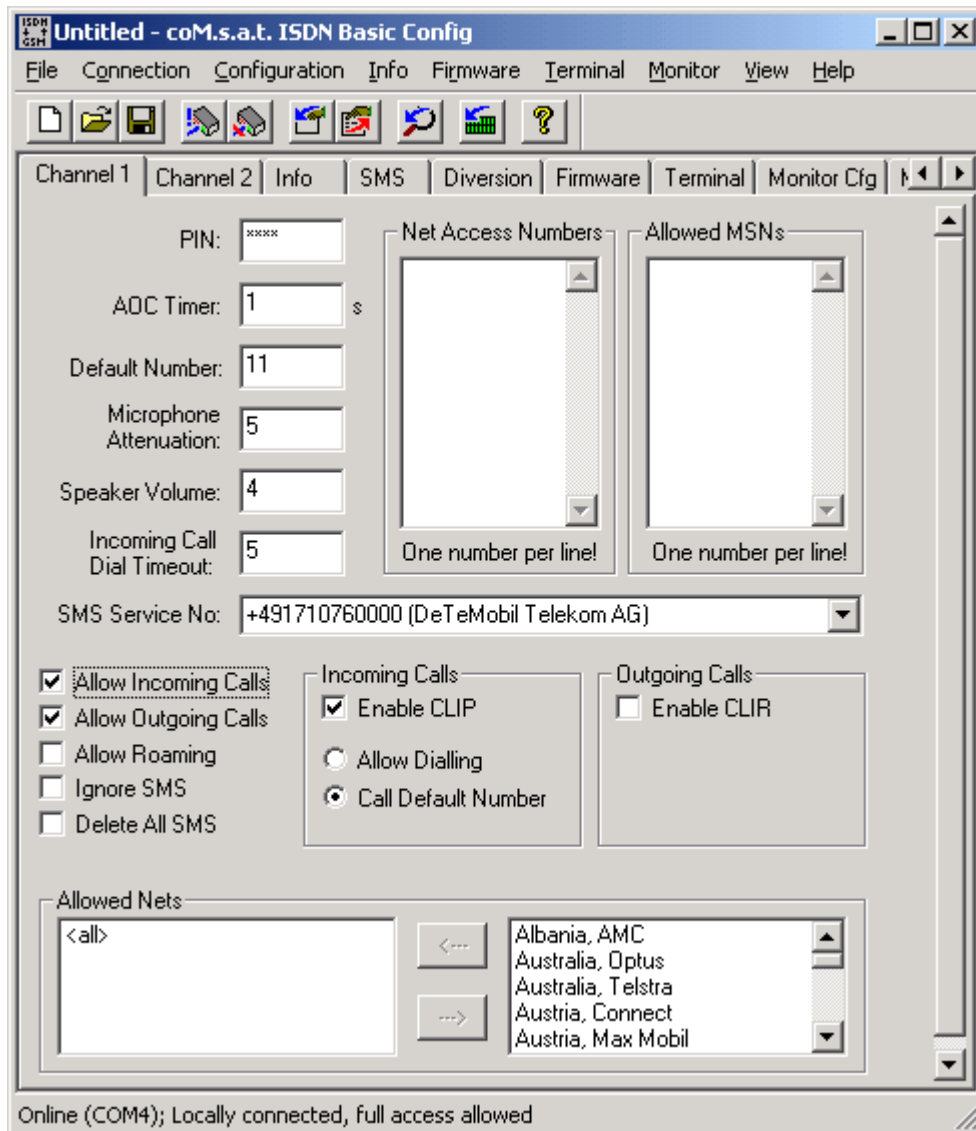

Figure 31: Vendor Functions in channel 1/2

Within the “**Channel 1**” and “**Channel 2**” tabs, the list boxes “**Allowed Nets**” is displayed above the lower edge if you have logged into the TA with full access rights (both passwords must be known). Network providers, into whose network the SIM cards may log into, can be designated by selecting from the right-hand list box and clicking the “arrow left” button between the boxes. They can be removed from the selection list by marking them and then pressing the button with the arrow to the right.

4 Installation and operating information

Due to the diverse settings possible using the **coMsat.exe** configuration program there is a wide range of possible applications. As it is impossible to list and describe all these applications here, the following is limited to those currently considered the most important.

4.1 coM.sat ISDN Plus replaces network termination

To use the **coM.sat** ISDN Plus as network termination, the following connection schematic results. This can vary depending on the TC system used, although the principle arrangement is retained. The **coM.sat** ISDN Plus is installed as an exchange (NT) at the external S0 bus.

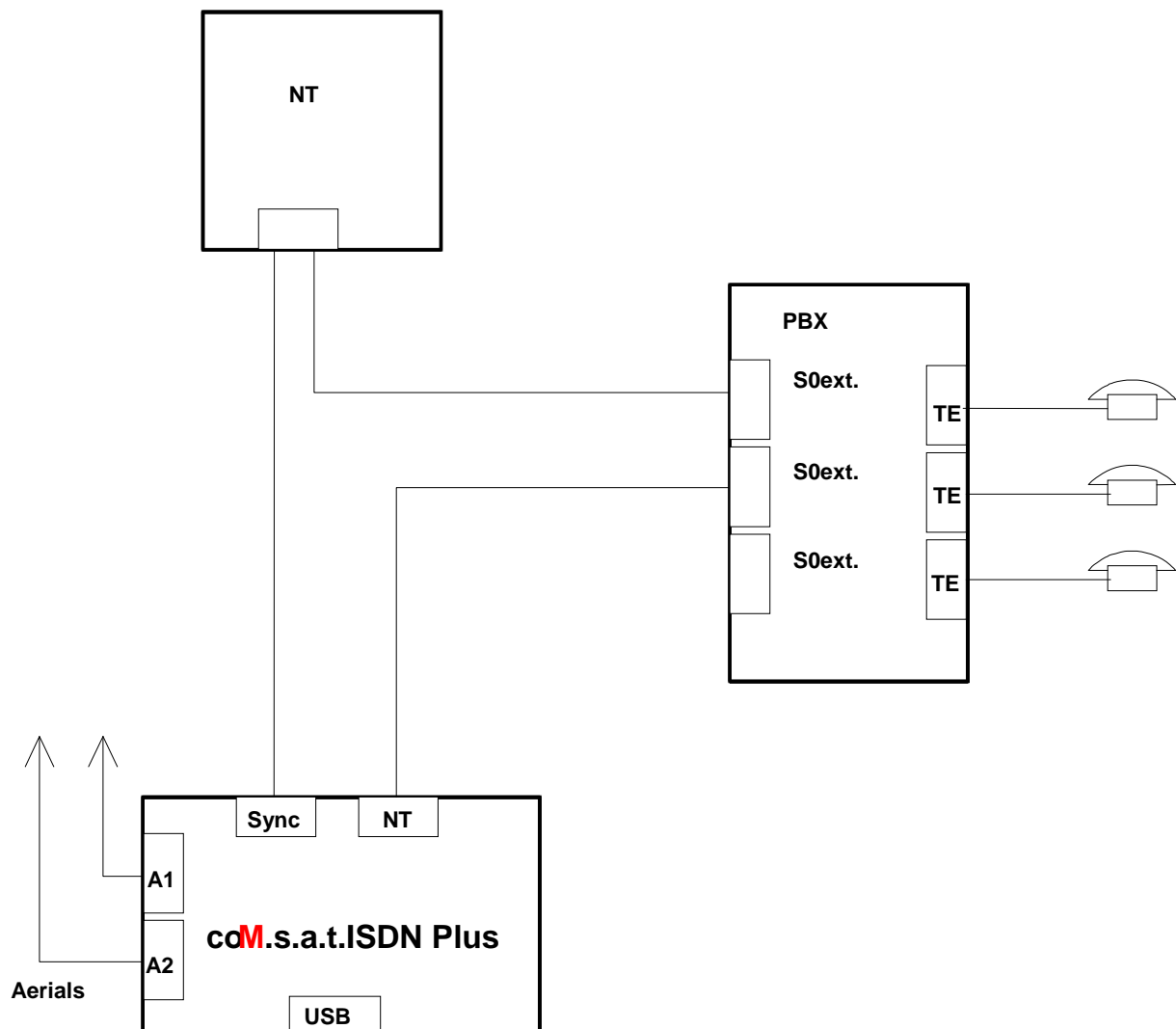

Figure 32: NT Installation

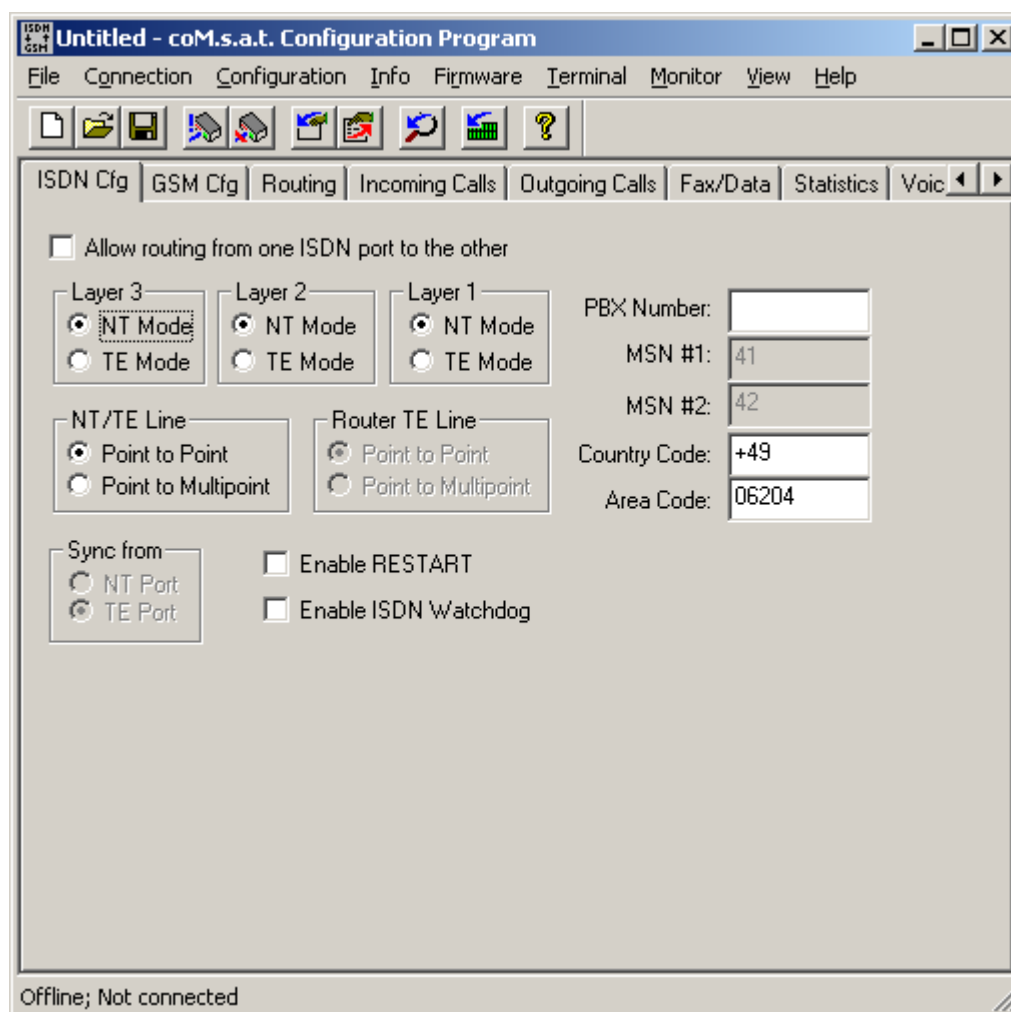

Figure 33: NT Configuration

This operating mode enables differences that may possibly occur between the clock pulses in the telephone network and in the coM.sat ISDN Plus to be avoided if the socket labelled "TE/Sync" is connected with the NTBA connection of the public network.

Correct installation of the TA can be identified from the LEDs. If the GSM modules have booked into the respective network, the green LEDs light up permanently. If one of the modules logs off from the network during operation, the corresponding green LED of this channel begins to flash slowly. The yellow LEDs are always off when no call is being made. While a connection is being set up they flash and they are permanently lit during a connection.

Monitoring of the ISDN lines is switched on or off using the "Enable ISDN Watchdog" check box. If the box is checked, the monitoring is active on. A reset is then performed after about 100 seconds if no ISDN connection could be established. If the watchdog is switched off, no reset occurs. In both cases the yellow LEDs indicate the state of the ISDN connection. If there is a problem with the physical connection, the yellow LED associated with channel 1 will be flashing. This indicates a problem with

the connected device, e.g. a wrong cable. If the logical connection can not be established, the second channel's yellow LED will be flashing. This indicates most likely a configuration problem, e.g. a mismatch of point to point and point to multipoint configuration.

4.2 coM.sat ISDN Plus in TE mode

If a **coM.sat** ISDN Plus TA is to be operated in TE mode, the following connection schematic results. This can vary depending on the TC system used, although the principle arrangement is retained. In TE mode, the **coM.sat** ISDN Plus is installed as an internal extension (TE), i.e. it is operated at the internal S0 bus and behaves like a standard ISDN device. In this case, no synchronisation via the basic link is necessary.

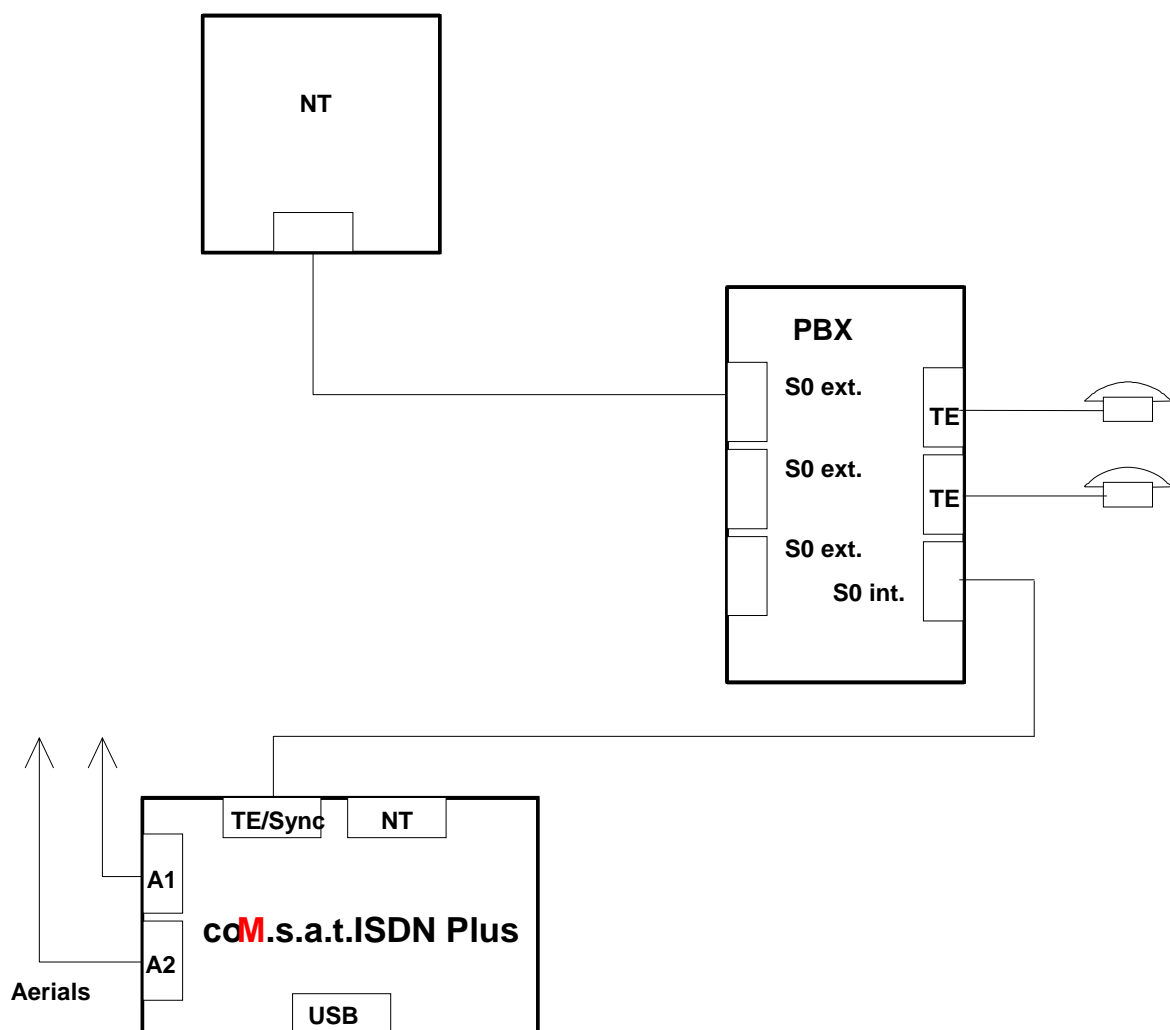

Figure 34: TE Installation

The following figure shows the settings for a possible and proven configuration. All layers have been set to TE mode and a point to multipoint link has been set. The synchronisation is carried out via the TE port.

In this mode the green LEDs function as in NT mode, i.e. if they are permanently lit, this shows that the GSM channels are logged in. If no call is being made then the yellow LEDs are off. While a connection is being set up, the yellow LEDs flash. Once the connection has been made, this is indicated by the LEDs being permanently lit.

Furthermore, the connection to the TC system is also monitored and displayed. Correct function in TE mode is indicated by the red LED labelled "Sync" being permanently lit. On the other hand, the red LED (Sync) is off or flashes and the two yellow LEDs flash if there is a malfunction.

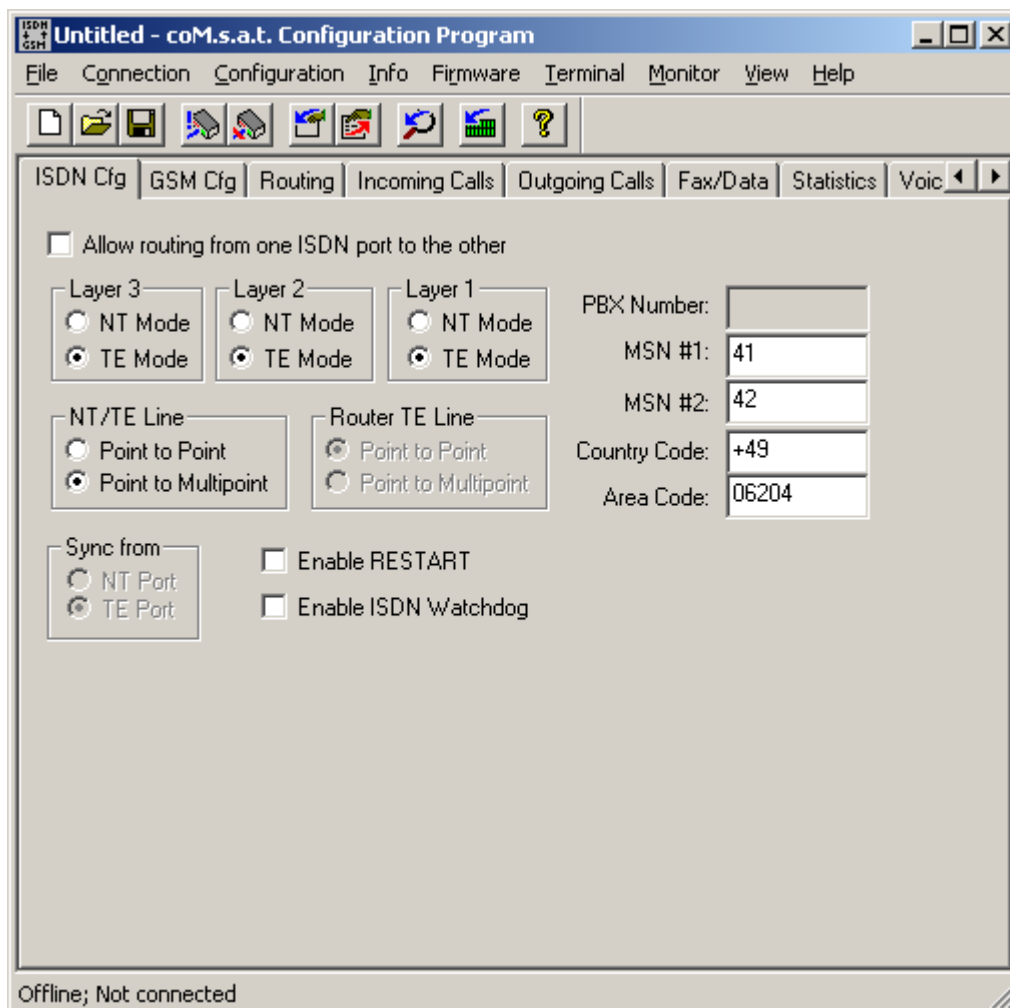

Figure 35: TE Configuration

4.3 coM.sat ISDN Plus in router mode

To use the **coM.sat** ISDN Plus as router, the following connection schematic results. This can vary depending on the TC system used, although the principle arrangement is retained. The **coM.sat** ISDN Plus is installed as an exchange (NT) at the external S0 bus and as TE at the ISDN network termination.

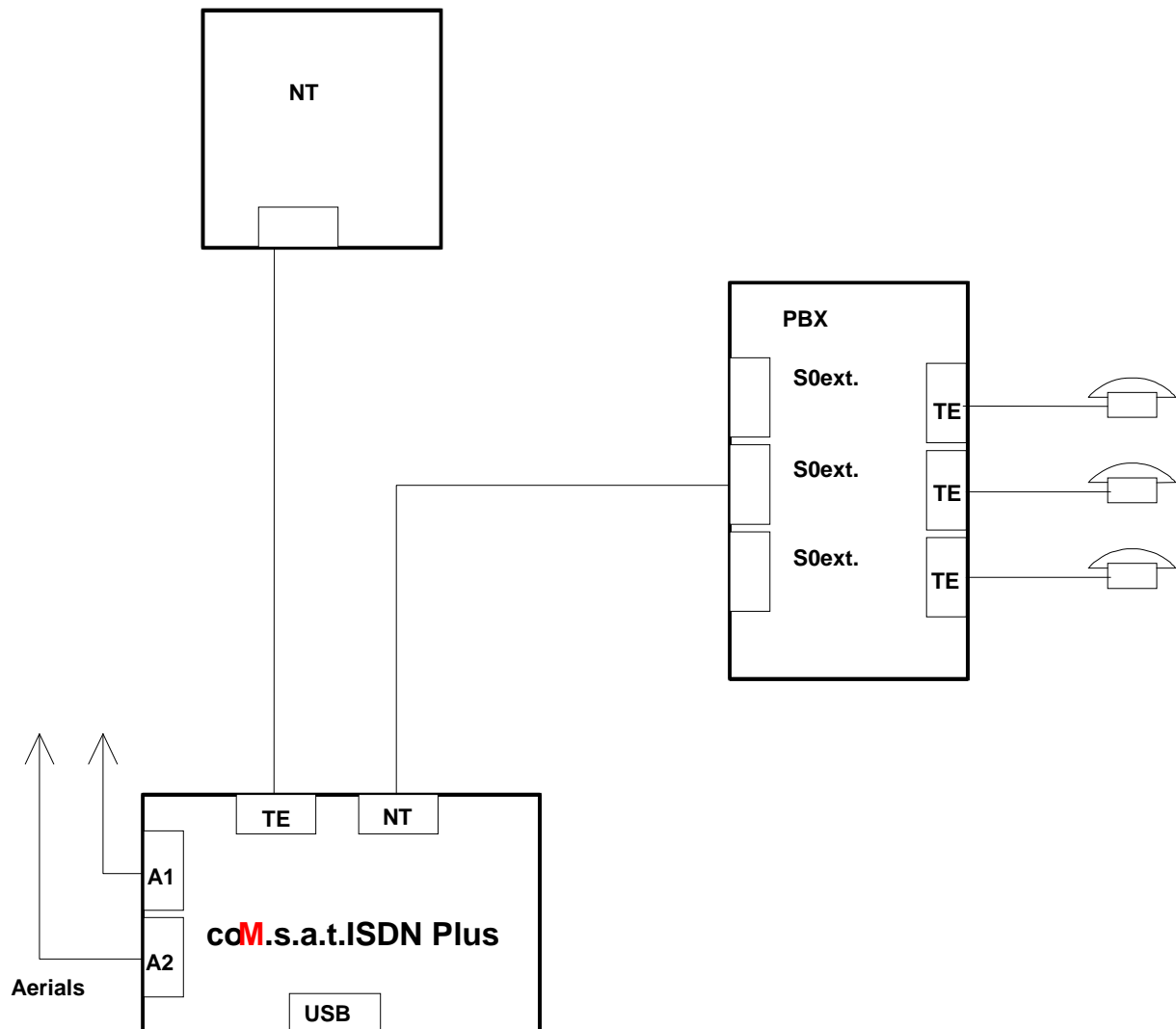

Figure 36: Router Installation

4.4 Transmit SMS

“Short messages“ can also be received and sent using the **coM.sat** ISDN Plus by connecting a PC on which the **coMsat.exe** application is installed to the **RS232 port** of the **coM.sat** ISDN Plus. After the link between the PC and the **coM.sat** ISDN Plus has been set up, the SMS card via which the SMSs are received and sent is called up.

Note: To do this, it is first necessary for the service centre numbers to be configured in the GSM channel card(s).

After selecting a channel, the SMSs are simply received by clicking on the “**Query**“ button, thereby reading the short messages from the SIM card. Any incoming messages are then shown in the upper box as a string in which the date, time and telephone numbers of the sender are displayed. The actual message text is displayed in the lower box when the message in the upper box is selected with the mouse. The text of a message can then be marked with the mouse and copied into the clipboard using the standard Windows keyboard shortcut <CTRL> <C> to make it available to another Windows application.

To send a short message, the text is entered in the lower box or transferred from the clipboard using the keyboard shortcut <CTRL> <V>. Then the transmission channel has to be selected and the number of the recipient entered. The short message is then transmitted by pressing the “**Send**“ button. Supplementary information can also be found in Chapter 3.3.16.

4.5 Transmit a fax

Apart from speech communications and SMS transmissions, the **coM.sat** ISDN Plus can also be used for receiving and sending fax messages. This is possible in two basic variants.

- 1) A fax program is loaded onto the PC (e.g. Winfax Pro) and then functions as a “Group 1 fax machine“ at the serial port of the **coM.sat** ISDN Plus.
- 2) A standard fax machine (group 3) is plugged into an analogue extension of the TC system at which the **coM.sat** ISDN Plus is installed. This way the fax messages can also be transmitted by **GSM**.

4.5.1 Fax transmission via PC

A PC on which an application is installed and with which it is possible to exchange fax messages (e.g. WinFax Pro) is connected to the serial port of the **coM.sat** ISDN Plus. The fax messages are now exchanged from this PC via the **coM.sat** ISDN Plus to a fax machine and vice versa or even from a **coM.sat** ISDN Plus with connected PC to another **coM.sat** ISDN Plus with connected PC. To transmit fax messages, a SIM card must be used on which the fax message transmission option has been authorised.

4.5.1.1 Preparation of the PC for fax transmissions

Before installing the fax program on the PC to be used for the transmission of fax

messages, the **coM.sat** ISDN Plus must first be installed as a modem. This required the **“ISDNPlus.inf”** file included in the software provided. To install the modem, call up Windows control panel and select **“Modems”**. The **“Modem Properties”** window then opens. Select the **“Add”** button and the **“Install New Modem”** window opens. Select the **“Select Modem (no automatic identification)”** option and then press **“Next”**. Another **“Install New Modem”** window now opens in which the **“Disc”** button is pressed. The **“Install from Disc”** window now appears at the foreground. Now click the **“Browse”** button in this window. The path to the directory in which the **“ISDNPlus.inf”** file is stored is then displayed in the following **“Open”** window and accepted with the OK button. The window now closes again and the **“OK”** button pressed in the **“Install from Disc”** window that is now in the foreground.

The **“Install New Modem”** window is now in the foreground and the list box of modems includes the **coM.sat** ISDN Plus. After pressing the **“Next”** key the serial port (e.g. COM port (COM 1)) must be selected, via which the communications with the **coM.sat** ISDN Plus are to be made later. If **“Next”** is then clicked on in this window, the modem is installed. The end of the installation is confirmed by the message **“The modem is now configured”** and concluded by pressing the **“Finish”** button. The **coM.sat** ISDN Plus is now included in the Modem Properties window.

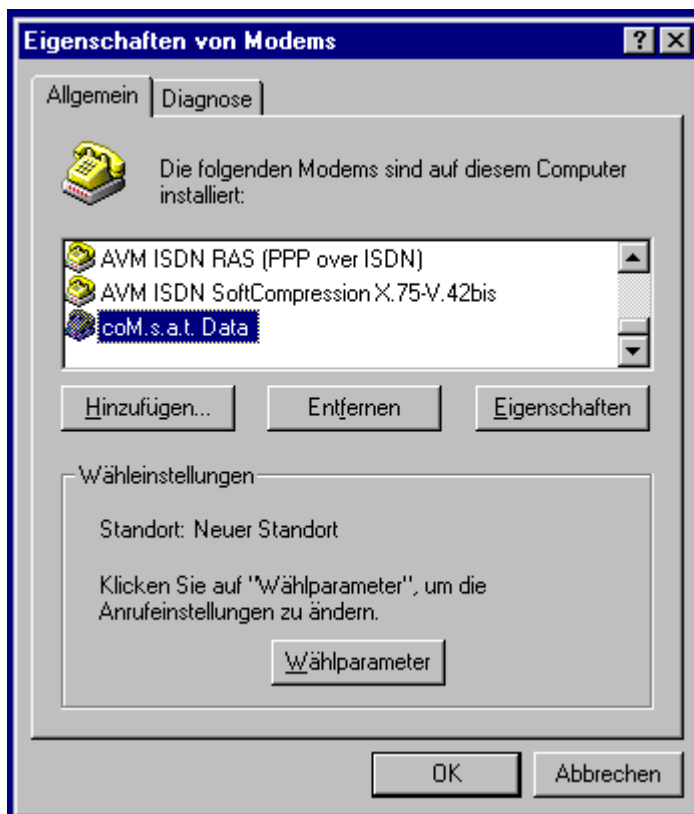

Figure 37: Install modem

Then the fax program can be installed by following the manufacturer’s instructions and documentation. When entering the modem to be used, select **coM.sat** ISDN Plus.

Note: Within the WinFax Pro application, the best results were achieved when transmitting fax messages to the **coM.sat** ISDN Plus when the ECM for receiving option and the High Speed Compression (2D) option were switched off and the maximum baud rate was set to 9600 Bd.

4.5.1.2 Send fax messages

If the installation has been carried out as described above and WinFax Pro has been set up, a fax message can now be sent directly from a word processing program, e.g. Microsoft Word 97 or similar. After the file has been completed and is ready for printing, the printing procedure is initiated by selecting **Print** from the file menu and selecting WinFax as the printer in the **Printer** window that then opens. The printing process is now diverted via WinFax and sent as a fax. After initiating the printing process, the WinFax **Send Fax Wizard** is called up in which only the phone number of the recipient must be entered.

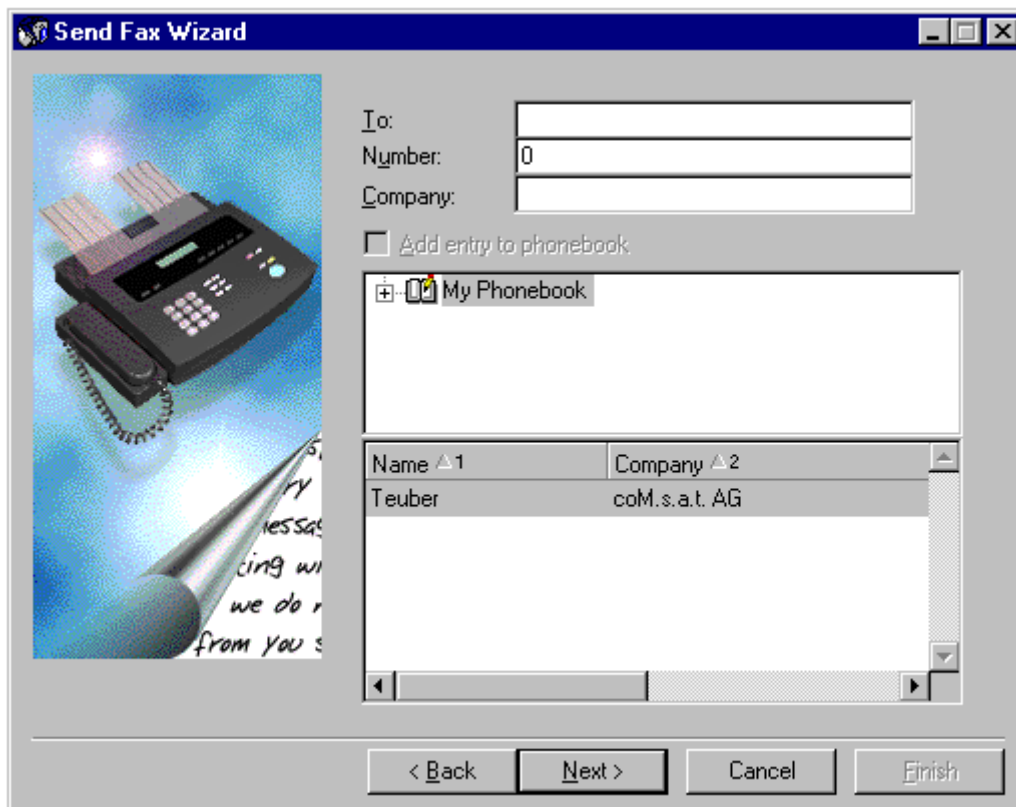

Figure 38: Send Fax Wizard

4.5.1.3 Receive fax message

Following standard installation, WinFax Pro remains ready to receive in the background. This is indicated by a small fax icon in the Windows symbol bar. If a fax message is now received, the data is automatically passed by **coM.sat** ISDN Plus to the PC on which WinFax is installed via the serial port.

4.5.2 Operating a fax machine on an extension

If a group 3 fax machine is operated on an analogue extension of the TC system, it must first be configured according to the TC system manufacturer's instructions and additional information must be entered in the configuration of the **coM.sat** ISDN Plus. Namely, the extension (or MSN number) via which the fax messages are to be sent or received must be defined. These entries are made in the "Analog Fax" and "Fax Calls To" list boxes of the "Fax/Data" card (1 extension per row). The "Analog Fax" entry is for sending outgoing fax messages and "Fax Calls To" for incoming fax messages. Fax machines are usually used for both directions, so the same extension numbers can be entered in both fields.

4.6 Data Transmission

Apart from communicating speech and transmitting SMS and fax messages, **coM.sat** ISDN Plus can also be used for receiving and sending data. This is achieved either via a PC connected with the serial port of the **coM.sat** ISDN Plus or via a PC whose serial port is connected to an analogue input (extension) of a TC system via a modem. However, in both cases setting up the link is similar.

4.6.1 Operating the PC at the serial port of the **coM.sat** ISDN Plus

A PC with an installed application that can exchange data (e.g. Hyperterminal) is connected to the serial port of the **coM.sat** ISDN Plus. The data exchange is now carried out from this PC to another device capable of receiving data and vice versa. The other device can also be a **coM.sat** ISDN Basic with connected PC and a program for the exchange of data. It is also possible to connect into the Internet if an Internet browser (Netscape, Microsoft) is running on the PC connected to the **coM.sat** ISDN Plus and the connection with the Internet has been made via GSM.

To transfer data, a SIM card must be used on which the data exchange option has been authorised.

4.6.1.1 Preparing the PC for the transfer of data

The program required for the transfer of data must have been installed on the PC to be used for the transfer.

For example, Hyperterminal can be used for the transfer of data, or even the Internet browser. As these programs are usually already installed on the PC, no explanation is given for their installation here.

4.6.1.2 Sending and receiving data

After calling up the terminal program on the receiver and sender side, the receiver side is set in the operating mode for receiving calls while the receiver station is dialled by the sender side. After establishing the link, the data can be exchanged either by entering directly via the keyboard or by transferring files.

Internet access is achieved by dialling an Internet access by GSM and if necessary entering a personal access number.

4.6.2 Operating the PC as an extension

In this case, the PC must either be equipped with an internal modem or an external modem is operated via a free serial port of the PC. In both cases, a link is established with an analogue port of the TC system and if necessary, the TC system is set up for data traffic via the PC. The necessary programs (terminal program, Internet browser) must have been loaded onto the PC itself and be ready for data transmission. The data is then transmitted in the same way as the transmission via the serial port of the **coM.sat** ISDN Plus.

4.7 Servicing / Remote servicing

The **coM.sat** ISDN Plus TA configuration can be checked in several ways, and the device firmware can be updated in a similar way. This type of servicing no longer requires that the TA be uninstalled and opened. The following methods are available.

- Servicing via the RS232 port of the TA
- Remote servicing per GSM

In both cases, a PC on which the **coMsat.exe** Windows application has been installed is required.

4.7.1 Servicing

If a PC is available at the installation site, a RS232 link is established between the **coM.sat** ISDN Plus and the PC and after calling up the **coMsat.exe** application, the link to the TA can be established by logging in for making authorised changes to the configuration. The next steps are then reading the configuration or updating the firmware.

4.7.2 Remote servicing

The other possibility is to set up a link between the service PC and the TA via a GSM network. To do this, a **coM.sat** ISDN Plus, a **coM.sat** ISDN Plus or a GSM modem must be connected to the service PC itself. Furthermore, the numbers of the TAs to be serviced must also be known at this site. The link is now made as follows:

The service PC sends the **coM.sat** ISDN Plus a short message (SMS) containing the callback number. The device then sets up a data link.

After the SMS has been sent, the service PC is switched over to the terminal window and the channel via which the message was transmitted was switched to transparent mode. When the return call is received, a “**RING**” can be identified in the terminal

window. The “RING” is now manually answered with the “ATA” command. The link to the remote device is now displayed by the “CONNECT” message. After setting up the link, the service PC can be used to work with the remote device, as if it were connected directly to the PC. For example, the configuration data can be interrogated, altered and sent back. In this process, a SIM card that permits the transfer of data must be inserted in the device used in the service centre. The phone numbers and, if necessary, the passwords of the remote device must be known.

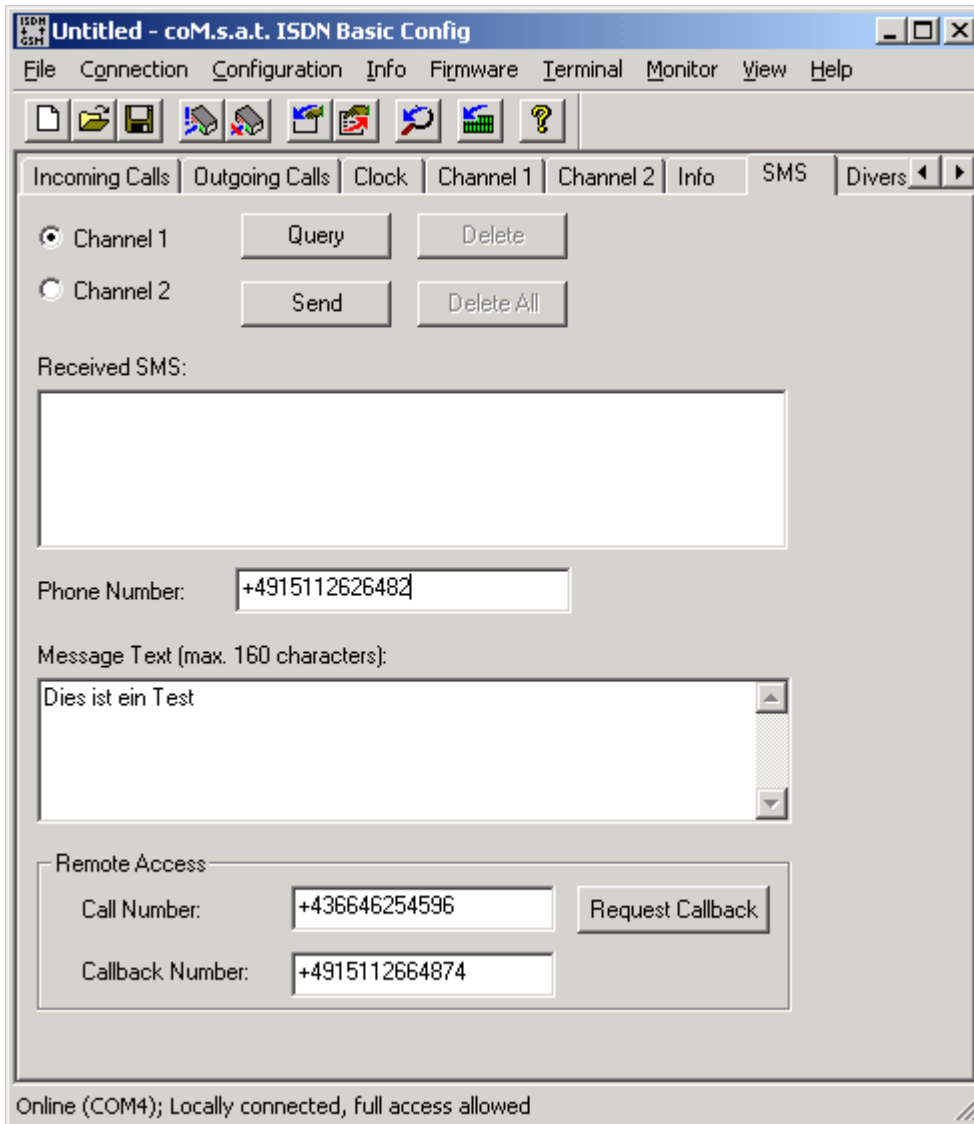

Figure 39: Remote Servicing

These two phone numbers are entered in the “**SMS**” file card within the **coMsat.exe** application. To do this, it is necessary to log in with full access rights. The phone numbers are then entered in the “**Call Number**” and “**Callback Number**” boxes. The “**Call Number**” gives the GSM phone number of the station to be called and serviced. The “**Callback Number**” is the number of one of the SIM card in the channel of the service station that transmits the SMS. Furthermore, the “**SMS Service Number**” must be entered for the channel on the service station side in the “**Channel 1(2)**” tab. By selecting the “**Request Callback**” button, the remote servicing process is initiated. In the first step, an SMS is sent to the device to be serviced. This then sets up a data link to the service centre.

As soon as the reply:

RING

arrives from the called device, input

ata

from the keyboard to pick up the link.

The device called answers after a short time with

CONNECT.

The link to the device to be serviced has now been established. The link is identified by the relevant information being displayed on the status bar. It is then possible to log in into the remote device to be serviced via the currently running **coMsat.exe** application. All other operations on this device are carried out as already described.

It is important that the link is set up from the remote device to avoid installing SIM cards capable of incoming data calls have to be installed in the remote device only for update and service purposes.

If the link is to be disconnected, the string

+++

OK

ath

is entered at the PC. The “+++” calls up the command mode of the device again and “ath” ends the link.

If an update of the firmware is made a reset is carried out on the device called after receiving and accepting the data, to be able to carry on working with the new data afterwards.

Note: If the SMS is sent manually, a MODEM attached to the fixed telephone network or a GSM MODEM can also be used for remote servicing.

4.7.3 Read out/Transmit configuration

After logging in into a **coM.sat ISDN Plus**, the configuration is read out by selecting "**Configuration**" in the menu bar and "**Query**" in the menu that opens. **coM.sat ISDN Plus** then interrogates the configuration and displays it via the **coMsat.exe** application. The **coMsat.exe** application can now be used, if required, to make the necessary changes. Then the configuration data are transferred back into the **coM.sat ISDN Plus** by again selecting "**Configuration**" in the menu bar and then "**Update**" in the menu that opens.

4.7.4 Software update

After logging in into a **coM.sat ISDN Plus** the current version of the firmware is automatically read or can be read out by selecting "**Firmware**" in the menu bar followed by "**Query**" in the menu that opens. The **coM.sat ISDN Plus** then interrogates the status of the firmware and displays it in the "**Firmware**" card of the **coMsat.exe** application.

The firmware is updated by selecting "**Firmware**" in the menu bar followed by "**Update**" in the menu. The familiar Windows dialog then opens with actions such as **Open File**. The "**Firmware.bin**" file to be transferred is selected from the list box and after pressing the Open button is transferred to the **coM.sat ISDN Plus** to which it is linked.

5 Questions and answers

Question: **coM.sat ISDN Plus** is being configured with the aid of a PC. But access to the device is apparently not possible.

Answer: You have forgotten to login.

The wrong port (COMx) has been selected in the Interface card in the **coMsat.exe** application.

Question: The **coM.sat ISDN Plus** is being configured with the aid of a PC but without a TC system having been connected. All the LEDs suddenly start to flash and access to the device is no longer possible.

Answer: In this operating mode, a "reset" is carried out at intervals of around 100s. You have to login again after a "reset" and after the device has been started up again.

Question: The **coM.sat ISDN Plus** is supposed to be configured for NT mode, but it won't start after downloading the configuration data.

Answer: All three optional layers, Layer 1 - 3, have not been selected for NT mode.

Question: The **coM.sat ISDN Plus** is supposed to be configured for TE mode, but it won't start after downloading the configuration data.

Answer: All three optional layers, Layer 1 - 3, have not been selected for TE mode.

Question: The monitor card is selected during operation but nothing changes within the card or it remains empty.

Answer: The trace memory in the device is only read out on request. To do this, select **Monitor** in the menu bar and then select "Load". The display in the card is deleted by selecting "Clear" from the menu. Attention: The content of the memory is not continuously transferred to the PC after the first request with "Load"! A new enquiry must be made for each update.

Question: The SIM card PIN numbers have been entered via the **coMsat.exe** application and entered in the **coM.sat ISDN Plus**. However, the device fails to book in. The green LEDs, which indicate booking in by being continuously lit, continue to flash.

Answer 1: SIM cards must be used that can work with an operating voltage of 3V. All new SIM cards are usually suitable. If older SIM cards are used, which are only designed for 5V operation, it is possible that the device cannot book into the network despite the correct PIN number being entered. Ask your network provider what type of SIM cards they issue.

Answer 2: The antennas have not yet been connected.

Question: Are the antenna affected if they are set up too close?

Answer: Yes, if two antennas are used, they must be set up at least 1 m apart to keep the effect they have on each other to a minimum.

Question: Why can't a GSM caller dial in even though he should be able to?

Answer: There are TC systems that forward all calls without called party number to a specific extension. In the normal configuration, the **coM.sat ISDN Plus** reports an incoming call to the PBX without called party number to check, if it is able to handle a call. If the PBX already starts alerting an extension on that message, the GSM user can not dial anymore. Change the setting of the "Dialling Mode" on page "Incoming Calls" to "En-bloc". Then no message is sent to the PBX until the complete called party number is available.

6 Technical data

Power supply unit	9-14 V DC, max 1,4 A
Current consumption	max 420 mA average quiet current max 1,2 A operating current (2 channels active)
GSM 900/1800 Standard	GSM Phase II Voice Data (max. 14400 bps) Fax (Class 1, group 3) SMS (Receive / Send in text mode)
Transmitter power	max. 2 Watt per channel (GSM 900) max. 1 Watt per channel (GSM1800)
SIM Card	3V SIM card
Interfaces	RS232 interface connector for programming and monitor operation, sending and receiving SMS messages, data and fax connections S ₀ interface (NT or TE, P-P or PMP settable, EDSS-1 protocol, impedance 100 Ω) as RJ 45 socket
Antenna	50 Ω impedance on BNC socket
Dimensions (B x D x H)	260 x 185 x 88 mm
Weight	approx. 1,8 kg
Temperature range	0 °C to 40° C

6.1 Connector assignments

Electricity supply:

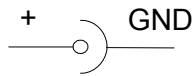

Central carrier wire: +9..12V
 External conductor: GND

NT Connection:

NT	PIN	EIA	Description
	1	NC	No Connection
	2	NC	No Connection
	3	Rx+	Receive Data +
	4	Tx+	Transmit Data +
	5	Tx-	Transmit Data -
	6	Rx-	Receive Data -
	7	NC	No Connection
	8	NC	No Connection

TE/SYNC Connection:

Sync	PIN	EIA	Description
	1	NC	No Connection
	2	NC	No Connection
	3	Tx+	Transmit Data +
	4	Rx+	Receive Data +
	5	Rx-	Receive Data -
	6	Tx-	Transmit Data -
	7	NC	No Connection
	8	NC	No Connection

Appendix 1: LED Function

The **coM.sat ISDN Plus** features altogether 6 LED's in different colours, intended to display the different operating conditions. An imprint on the housing allows for the identification of the LEDs' function.

Name	LED colour	Status	Meaning
Power	red	on	ready, on
		off	off
Sync	red	on (TE) or flashing (NT)	TE Mode: ISDN connection up NT Mode: Synchronisation present
		off	TE-mode: line fault NT-mode: device is operated w/o synchronisation, or line fault
Network	green	off	Booting
		flashing quickly	GSM channel not ready (initializing, no SIM card, incorrect PIN, ...)
		flashing slowly	GSM channel presently logging into network
		on	GSM channel currently logged into network
Active	yellow	off	no connection via channel
		Flashing quickly	no ISDN link (one LED for layer 1 and one for layer 2)
		Flashing slowly	connection is being established or transparent access by PC over RS232
		on	connection is established

Appendix 2: Terminal commands

When using the terminal window of the **coMsat.exe** application it is possible to both directly access the GSM modules as well as the device itself using special commands. The commands for the GSM modules are not described here as they are described in the GSM module manufacturer's documentation. The special commands for the **coM.sat** ISDN Plus are described in the following:

Command	Meaning
at\$ =“<password>“<enter>	Login to the TA if the password is correct. If the <password> =<configuration password> <vendor password>, full access to the TA's functions is possible.
at\$i<enter>	Returns the identification and status of the modules
at\$t1<enter>	Transparently switches to Channel 1 if the TA is in the “Ready“ state. It is necessary to login first!
at\$t2<enter>	Transparently switches to Channel 2 if the TA is in the “Ready“ state. It is necessary to login first!
at\$x1<enter>	Transparently switches to Channel 1 in any state (caution!!). It is necessary to login first!
at\$x2<enter>	Transparently switches to Channel 2 in any state (caution!!). It is necessary to login first!
at\$&f<enter>	Reinstates the factory settings. It is necessary to login first!
at\$r<enter>	Reset the device. It is necessary to login first!
ati<enter>	Issues brief information
ate0<enter>	Switches the echo mode off.
ate1<enter>	Switches the echo mode on.
at\$dv <enter>	Deletes all stored voice announcements. It is necessary to login first!
at\$time? <enter>	Answers the current time of the device
at&d0 <enter>	Ignores the state of the DTR line, i.e. the PC can disconnect the local connection without automatic logout; transparent connections are also not disconnected automatically (attention: can only be disconnected by restarting the device!)
at&d2 <enter>	Watches the state of the DTR line again (see above)
at\$smslist=<channel> <enter>	Answers a list of stored SMS on <i>channel</i> (1 or 2).
at\$smsend=<channel>,” <number>”,<text>” <enter>	Sends an SMS with <i>text</i> to <i>number</i> via <i>channel</i> (1 or 2).
at\$smsdelete=<channel>,” <index>” <enter>	Deletes the SMS with <i>index</i> of <i>channel</i> (1 or 2). The index is the first number in the output of a received SMS
at\$cdrg <enter>	Returns the statistics (Call Data Records)
at\$cdrd <enter>	Deletes the statistics
at^moni<enter>	Replies with information about the cell, field strength, network provider, etc. (Transparent connection to GSM module required)

at^moni=1<enter>	Replies cyclically every second with information about the cell, field strength, network provider, etc. (Transparent connection to GSM module required)
------------------	---